

AIRSTREAM

AN AMERICAN LEGEND

LAND YACHT MOTORHOME

OWNERS MANUAL

2006

INTRODUCTION

The Owners Manual for your new Airstream Motorhome is designed to respond to the most frequent inquiries regarding the operation, function and care of the many systems that make modern motor homing a joy.

Airstream realizes our customers possess varying degrees of expertise in the area of repairing and maintaining the appliances in their motorhome. For this reason, the service and trouble-shooting information found in this manual is directed toward those with average mechanical skills. We also realize you may be more familiar in one area than you are in another. Only you know your capabilities and limitations.

We want you to use this manual, and hope you will find the information contained in it useful, however, should you ever feel you may be "getting in over your head" please see your dealer to have the repairs made.

The operation and care of component parts such as chassis, refrigerator, furnace, water heater and others are briefly explained in this manual. However, you will also find the complete manufacturer's information supplied in a packet included with this manual.

Note: All information, illustrations and specifications contained in the literature are based on the latest product information available at the time of publication approval. Airstream reserves the right to make changes if and when new materials and/or production techniques are developed that can improve the quality of its product, or when material substitutions are necessary due to availability.

Throughout this manual **CAUTION** and  **WARNING** notations are used.

Failure to observe "**CAUTION**" can cause equipment damage if not observed..

Failure to observe “  **WARNING**” can lead to damaged equipment, serious personal injury and/or death if not observed.

Please read and follow all cautions and warnings. If any questions arise contact your dealer or the factory customer service department.

TABLE OF CONTENTS

A. WARRANTY AND SERVICE	Fabric Care and Cleaning Drapes
Warranty Warranty Explanation Service Reporting Safety Defects Maintenance Schedule	G. PLUMBING
B. DRIVING	LP (Liquid Petroleum) Gas Water System Water Pump City Water Hookup Black Tank Flush Exterior Water Service Faucets Toilet Storage and Winterizing Drainage System
Loading Weighing Safety Check List Airstream Dash Controls Motorhome Towing & Driving Tips Weighing the Motorhome	H. ELECTRICAL
C. CHASSIS	Battery Control Center 12-volt system 12-Volt Wiring Diagrams Monitor Panel TV Antenna Solar Panel 110-Volt Power Switch-over Box Shorts and Opens 110-Volt Wiring Diagrams
Component Identification Dash/Air Conditioner/Heater Tire/Wheels Electric Step	I. APPLIANCES
D. CAMPING	Air Conditioner Furnace Refrigerator Range/Oven Microwave Oven Water Heater Power Roof Vent Satellite System
Camping Safety Smoke Alarm LP Gas Alarm Overnight Stop Winter Traveling Extended Stay Slide Out Room	J. SPECIFICATIONS
E. EXTERIOR	Coach Chassis
Cleaning Doors/Locks Keyless Entry Roof Ladder Power Awning	
F. INTERIOR FURNISHINGS AND ACCESSORIES	
Lounge, Chair, Dinette Shades Flooring Counters Walls/Cabinets Bathroom	

WARRANTY AND SERVICE

AIRSTREAM INC. LIMITED WARRANTY

WARRANTY COVERAGE

When you buy a new Airstream Land Yacht Motorhome from an authorized Airstream dealer, Airstream, Inc., warrants the motorhome from defects in material and workmanship as follows:

BASIC WARRANTY PERIOD

This warranty is for 30,000 miles (40,000 Kilometers) or two years, whichever comes first, beginning when the vehicle is delivered to the first retail customer or first placed into demonstrator service. This warranty must have started prior to the accumulation of 4,000 miles in order to be valid.

ITEMS COVERED

Any part of the motorhome or any component equipment installed by the factory is covered by the basic warranty *except* the following items, which are *not covered*:

- House Batteries
- Automotive Chassis
- Generator

The above items will be handled by their respective service points and according to their written policy. This limited warranty does not include failure caused by accident, abuse, normal wear, overload or any cause not attributable to a defect in original material or workmanship of the motorhome or component equipment as installed by the factory.

LIMITATION OF IMPLIED WARRANTIES

All warranties of merchantability and fitness for a particular purpose, whether written or oral, express or implied, shall extend only for a period of two years from the date of original purchase, or 30,000 miles, whichever comes first. There are no other warranties, which extend beyond those described on the face hereof and which expressly excludes conditions resulting, from normal wear, accident, abuse, exposure or overload. Some states do not allow limitation on how long an implied warranty lasts, so the above limitations may not apply to you.

AIRSTREAM'S RESPONSIBILITY

The basic **Airstream Limited Warranty** applies for a period of two years from the date of original purchase or 30,000 miles, whichever comes first, and the application date of all warranties is that indicated on the owner's Limited Warranty. Defects in items covered under this Warranty will be corrected without cost upon the return, at the owner's expense, of the motorhome or defective part to an authorized Airstream dealer.

WARRANTY AND SERVICE

CARE AND MAINTENANCE

This warranty covers only defective material and/or workmanship; adjustments are made at the factory prior to shipment, and rechecked by the dealer prior to delivery to the customer. Adjustments thereafter become a customer responsibility.

The owner is also responsible for following all recommendations, instructions and precautions contained in the Airstream Motorhome Owner's Manual and the individual manuals furnished by the chassis, appliance and other manufacturers.

INSTALLATIONS NOT COVERED

Airstream, Inc., does not accept any responsibility in connection with any of its motorhomes for additional equipment or accessories installed at any dealership or other place of business, or by any other party. Such installation of equipment or accessories by any other party will not be covered by the terms of this warranty.

IF REPAIRS ARE NEEDED

If your motorhome needs repairs under the terms of the basic Airstream Limited Warranty, you should:

1. Take your motorhome to your selling dealer or other Authorized Airstream Dealer.
2. If the dealer is incapable of making the repair, request that he contact the Service Administration Department at Airstream, Inc., for technical assistance.
3. If repairs are still not made, the customer should contact:

AIRSTREAM, INC.
419 W. Pike Street - P.O. Box 629
Jackson Center, Ohio 45334-0629
Attention: Owner Relations Department

Furnish the following information:

- The complete serial number of the motorhome
 - Mileage
 - Date of original purchase
 - Selling dealer
 - Nature of service problem and steps or service, which have been performed. (The owner may be directed to another dealer at the owner's expense.)
4. If, after taking the above steps, repairs are still not complete, the Airstream owner may request the motorhome be allowed to be brought to the Factory Service Center at the owner's expense.

DEALER REPRESENTATION EXCLUDED

The full extent of the basic **Airstream Limited Warranty** is set forth in detail in the folder, and in the explanation of the basic **Airstream Limited Warranty** covered in the Airstream Motorhome Owner's Manual. Airstream Inc. will not be responsible for additional representations or implied warranties made by any of its dealers to the extent those representations are not a part of, or are contrary to, the terms and conditions of the basic **Airstream Limited Warranty**.

WARRANTY AND SERVICE

CONSEQUENTIAL AND INCIDENTAL DAMAGES

Airstream, Inc., will not be responsible for any consequential or incidental expenses or damages resulting from a defect. Incidental expenses include, but are not limited to: travel expenses, gasoline, oil, lodging, meals, telephone tolls, and loss of work and loss of use of the motorhome. Some examples of consequential damages would be: stained curtains due to rain leaks or delaminated floor caused by a plumbing leak. *Some states do not allow the exclusion or limitation of incidental or consequential damages, so the above limitation or exclusion may not apply to you.*

WARRANTY TRANSFER

The basic **Airstream Limited Warranty** is transferable to subsequent owners for the duration of the warranty period. Warranty transfer application forms are available from your dealer or the Airstream Inc. Service Administration Department.

CONSUMER ARBITRATION PROGRAM

Airstream, Inc. participates in the consumer Arbitration Program for Recreational Vehicle (CAP-RV). This third-party dispute resolution program is available, at no charge to you, to settle unresolved warranty disputes for recreational vehicles. This dispute resolution program reviews eligible product and service related complaints involving warranty covered components.

To find out more about this program, or to request an application/brochure, please call the Arbitration Administration office toll-free 800.279.5343.

For recreational vehicles purchased in the State of California: The CAP-RV program operates as a certified mechanism under the review of the California Arbitration Certification Program. You must utilize the arbitration program before claiming rights conferred by 15 USC section 2310 (Uniform Commercial Code) or Civil Code section 1793.22(b) (Son-Beverly Warranty Act). You are not required to use the program if you choose to seek redress by pursuing rights and remedies not created by those laws.

CHANGES IN DESIGN

Airstream Inc. reserves the right to make changes in design and improvements upon its product without imposing my obligation upon itself to install the same upon its products theretofore manufactured.

This warranty gives you specific legal rights, and you may also have other rights, which vary from state to state.

WARRANTY EXPLANATION

Along with your new Airstream motorhome you have purchased the Airstream Limited Warranty. Read your Limited Warranty carefully. It contains the entire agreement with respect to Airstream's obligation on the Limited Warranty on your new vehicle. The terms of the Limited Warranty, and only those terms, will define Airstream's responsibility. When you receive your Limited Warranty file it for safekeeping.

Upon proof of purchase date to any Airstream Dealer Service Center, defects in materials or workmanship will be repaired or replaced without cost to the owner for a period of twenty four (24) months from the original purchase date, or 30,000 miles, whichever occurs first. Written warranties of some manufacturers of components of the motorhome will be honored by Airstream for the duration on that manufacturer's warranty.

WARRANTY AND SERVICE

Items such as motorhome chassis, engine, tires, batteries and generator are serviced by their respective manufacturers and will be handled by their service centers according to the terms of their written policy. Any warranty forms from these manufacturers should be completed promptly, preferably at time of purchase.

Your motorhome chassis is pre-checked by its manufacturer before delivery to Airstream. All service to the chassis must be performed by the manufacturer according to the manufacturer's warranty and service policies. Literature is supplied with each Airstream motorhome that gives important information concerning its warranty coverage; however, the Airstream Limited Warranty covers the chassis heater, defrosters, windshield wiper blade, motor, washer, LP gas bottle and gas regulator.

Paint and appearance items that show imperfections should be brought to the attention of your dealer at the time of delivery and during pre-delivery inspection. Normal deterioration by use and exposure is not covered by the Airstream Limited Warranty.

Damage to enameled or porcelain surfaces resulting from abrasion, collision or impact, and broken window glass is not covered by the Airstream Limited Warranty.

The Airstream Limited Warranty Excludes:

Normal Wear:

Items such as water purifier packs, curtains, upholstery, floor coverings, window, door and vent seals may show wear within the one year Limited Warranty period depending upon the amount of usage, weather and atmospheric conditions.

Accident

Damage caused by accident is usually visible, and we strongly urge our dealers and customers to inspect the motorhome upon delivery for any damage caused by accident while being delivered to the dealer, or while it is on the dealer's lot. Damage of this nature becomes the dealer's or your responsibility upon acceptance of the motorhome. GLASS BREAKAGE, whether obviously struck or mysterious, is always accidental and covered by most insurance policies.

Abuse

Lack of customer care and/or improper maintenance, including failure to comply with the terms of the Owner's Manual, or failure to heed proper vehicle operation shown by the dash instruments is not covered by warranty.

Exposure

It is the responsibility of the owner to take such preventative measures as are necessary to maintain the exterior caulking and sealer of your unit. It is the responsibility of the owner to use reasonable, prudent care to prevent foreseeable secondary damage from rain, plumbing leaks, and the natural accumulation of moisture in your unit, such as a delaminated floor; stained upholstery, carpeting, or drapes; mold formation and growth; furniture damage, etc. Mold is a natural growth given certain environmental conditions and is not covered by the terms of the Limited Warranty.

Deterioration by sunlight is possible to such items as tires, curtains or upholstery. Steel or metal surfaces are subject to the elements, causing rust and corrosion that is normal and beyond the control and responsibility of Airstream.

WARRANTY AND SERVICE

OVERLOAD

Overload Damage due to loading beyond capacity or to cause improper balance is not covered by the Airstream Limited Warranty. The Airstream motorhome body is engineered to properly handle any normal load. There are limits to the amount of load that can be safely transported depending upon speed and road conditions. If these limits have been exceeded the Airstream Limited Warranty will not cover resulting damage. For additional information on the load capacity of your motorhome consult your Owner's Manual or gross vehicle weight rating plate. Each motorhome is aligned during the last quality inspection. These tolerances will only change if the motorhome is subjected to abuse, such as dropping off a sharp berm, striking a curb, or hitting a deep hole in the road. Such damage would be considered as resulting from an accident which risks are not covered under the warranty. Abnormal tire wear and/or wheel alignment resulting from such damage is not covered under the terms of the warranty.

SERVICE

The Airstream Silver Key Delivery Program is an exclusive Airstream program. Before leaving the factory each and every vital part of the motorhome is tested for performance. Each test is signed and certified by an inspector. After the motorhome arrives on your dealer's lot all of these vital parts and systems are again tested. When you take delivery of your new motorhome you will receive a complete checkout.

Please contact your dealer if you need service. Major service under your Airstream Limited Warranty is available through our nationwide network of Airstream Dealer Service Centers. An up-to-date list of Dealer Service Centers has been provided with your new motorhome. This list is current as of the date of publication.

Occasionally dealerships change, or new dealers are added who may not appear on this list. For this reason, it is suggested that you contact your local dealer from time to time and bring your list up to date. He can also provide you with additional copies if you need them.

ALL SERVICE CENTERS OPERATE ON AN APPOINTMENT BASIS FOR THE UTMOST EFFICIENCY.

When you require service from the Airstream Factory Service Center, or a Certified Dealer Service Center, please contact the service manager for an appointment, and kindly inform him if you are unable to keep the appointment date or wish to change it. Service may be arranged at the Factory Service Center by contacting the Service Coordinator at Airstream Factory Service Center, P.O. Box 629, 419 W. Pike Street, Jackson Center, Ohio 45334-0629, Phone 937-596-6111, Fax: 937-596-6802

REPORTING SAFETY DEFECTS

If you believe that your vehicle has a defect, which could cause a crash or could cause injury or death, you should immediately inform the National Highway Traffic Safety Administration (NHTSA) in addition to notifying Airstream, Inc.

If NHTSA receives similar complaints, it may open an investigation, and if it finds that a safety defect exists in a group of vehicles, it may order a recall and remedy campaign. However, NHTSA cannot become involved in individual problems between you, your dealer, or Airstream, Inc.

To contact NHTSA you may either call the Auto Safety Hotline toll-free at 1-800-327-4236 (TTY 1-800-424-9153) or write to: NHTSA, 400Seventh ST, S.W., Washington, D.C. 20590. Website: <http://www.safercar.gov>

WARRANTY AND SERVICE

MAINTENANCE SCHEDULE



Warning: FAILURE TO MAINTAIN YOUR COACH CAN CAUSE PREMATURE AND UNEXPECTED PARTS BREAKAGE AND/OR ERRATIC OPERATION THAT MAY BE HAZARDOUS. SERIOUS INJURY COULD RESULT FROM FAILURE TO HEED THIS WARNING.

Note: See chassis and appliance manufacturer's literature for further information.

EVERY 1,000 MILES OR 60 DAYS

Escape Window	Check operation of latches and upper hinge.
Smoke Alarm	Test and replace battery as required.
Tires	Check tire pressure See inflation warning on page C-9
GFI Circuit Breaker	Test and record.
Spare Tire System (30' & 33' only)	Check tightness and operation of winch. Check for worn and defective cable, washer, or yoke.

EVERY 5,000 MILES OR 90 DAYS

Exterior Door locks	Lubricate with dry graphite
Exterior Hinges	Lubricate with light household oil
LPG Regulator	Check bottom vent for obstructions
Main Door Striker Pocket	Coat with paraffin.
Wheel Lugs	Torque to chassis owner's manual specifications.
Range Exhaust Hood	Clean fan blades and wash filter.
Roof Vent Elevator Screws	Lubricate with light household oil
Main Door Step	Check and lubricate moving parts.

EVERY 10, 000 MILES OR 6 MONTHS

Exterior	Clean and wax.
Carbon monoxide alarm	Vacuum exterior only.

EVERY YEAR or 12,000 miles

Battery	Clean, neutralize and coat terminals with petroleum jelly.
LP Tank	Clean, neutralize and coat terminals with petroleum jelly.
Seams	Check and reseal exterior seams, windows, lights and vents if necessary. Reseal with Bostik urethane sealant or equivalent as needed.

WARRANTY AND SERVICE

NOTES

DRIVING

LOADING

Below is a sample of the weight information chart provided in all Airstream vehicles. This information can be found in your vehicle on the back of a wardrobe door.

MOTORHOME WEIGHT INFORMATION

VIN OR SERIAL NUMBER

GVWR (GROSS VEHICLE WEIGHT RATING) IS THE MAXIMUM PERMISSIBLE WEIGHT OF THIS FULLY LOADED MOTORHOME.

UVW (UNLOADED VEHICLE WEIGHT) IS THE WEIGHT OF THIS MOTORHOME AS MANUFACTURED AT THE FACTORY WITH FULL FUEL, ENGINE OIL AND COOLANTS.

SCWR (SLEEPING CAPACITY WEIGHT RATING) IS THE MANUFACTURER'S DESIGNATED NUMBER OF SLEEPING POSITIONS MULTIPLIED BY 154 POUNDS (70 KILOGRAMS).

CCC (CARGO CARRYING CAPACITY) IS EQUAL TO GVWR MINUS EACH OF THE FOLLOWING: UVW, FULL FRESH (POTABLE) WATER WEIGHT (INCLUDING WATER HEATER), FULL LP GAS WEIGHT AND SCWR.

CARGO CARRYING CAPACITY (CCC) COMPUTATION

	POUNDS	KILOGRAMS
GVWR		
MINUS UVW		
MINUS FRESH WATER WEIGHT OF GALLONS @ 8.3 LB/GAL		
MINUS LP GAS WEIGHT OF GALLONS @ 4.5 LB/GAL		
MINUS SCWR OF PERSONS @ 154 LB/PERSON		
= CCC FOR THIS MOTORHOME*		

*DEALER INSTALLED EQUIPMENT AND TOWED VEHICLE TONGUE WEIGHT WILL REDUCE CCC

CONSULT OWNER MANUAL(S) FOR SPECIFIC WEIGHING INSTRUCTIONS AND TOWING GUIDELINES. CD-130

See specification section in this manual for weights and term definitions.

WEIGHT DISTRIBUTION

The motorhomes have large fluid tanks and lots of storage areas. It gives you great flexibility in loading. With flexibility comes responsibility. If you want to load down all the storage compartments the amount of fluids will have to be reduced. Distribute your additional cargo as evenly as possible with the heaviest objects located as low as possible.

Do you really want to carry 750 pounds of water to a RV park 1,000 miles away and then hook up to a city water supply? Even if you're going to the "boondocks" you can usually fill your water tank shortly before entering the area. Just reducing your load by 10 gallons of water lets you carry an awful lot of fishing and camping gear.

WEIGHING

The unloaded vehicle weight (UVW), listed on the chart in your coach is the weight of the motorhome with the options as ordered and installed at the factory. It includes all weight at the axles with full generator fluids, including fuel, engine oil, and coolants. To determine the actual weight of your vehicle with personal cargo, water and LP, it must be weighed on scales. The most common scales are those used by states to weigh trucks used along the highway. In rural areas grain elevators are a good source and another would be a gravel pit. **Note:** Weighing instructions for this motorhome are explained later in this section.

If you have trouble locating scales, a call to your State Highway Patrol will usually find them very cooperative in assisting you.

DRIVING

SAFETY CHECK LIST

Your Airstream motorhome should be given a thorough safety check before a trip. Regular use of the following list will provide safe operation of your motorhome and will help you spot any malfunctioning equipment and correct the problem as soon as possible. The list is to help you and may not be all-inclusive.

Failure to heed the following items may cause damage to the vehicle or personal injury.

EXTERIOR CHECK LIST (BEFORE ENTERING VEHICLE)

1. Check condition of tires for proper inflation. **See tire inflation on page C-9.**
2. Turn off LPG valve on LPG tank.
3. Check that sewer connections, city water hookup, TV cable, and all exterior components are unhooked and properly stowed away.
4. Check that all external compartments and filler openings are properly closed and/or locked.
5. Check that items stored on exterior of vehicle are securely tied down.
6. Would any items stored on exterior of vehicle present a clearance problem?
7. Lower and secure awnings/TV antenna (satellite dish).
8. Follow all chassis manufacturers recommendations on checking and filling chassis fluid levels.

INTERIOR CHECK LIST (BEFORE DRIVING OFF)

1. It is important that the main door and cab door be completely closed and locked during travel. As an added precaution we recommend the dead bolt also be locked on the main door.
2. Turn off living area water pump.
3. Check that refrigerator door is fastened.
4. Check that nothing heavy is stored in overhead or high cabinets, which could fall out and cause injury. Heavy items should be stored in low cabinets.
5. Stow folding and pedestal tables.
6. Check that counter tops, range top, credenza tops and shelves are clear of even small items that could become projectiles in an accident.
7. Do not cook while under way. Hot food or liquid could scald due to a sudden stop or accident.
8. Be sure all LPG controls on furnace, range/oven and gas/electric refrigerator are turned Off.
9. Check that any internal stowage is securely held in place
10. Check that lights and switches are set in positions safe for travel.
11. Adjust the driver's seat so that you can easily reach and operate all controls. Make sure seat is locked in position. Do not adjust driver's seat swivel or fore and aft mechanism while vehicle is moving. The seat could move unexpectedly causing loss of control.
12. Check that front passenger's seat is locked in position - both fore and aft adjustment and swivel mechanism.

DRIVING

INTERIOR CHECK LIST (BEFORE DRIVING OFF)

13. Check rear view mirror adjustment, inside and outside. Adjust curtains if necessary for maximum visibility.
14. Secure children in a Federally Approved Child Restraint Device.
15. Fasten your lap belts.
16. Check that step light goes out and that electric step has retracted.

SAFETY SEAT BELTS

In the forward driver's area of the motorhome, safety seat belts are provided for the use of the driver and the right front passenger. Safety belts are available for other seats. It is strongly recommended that all occupants remain seated with their safety belts firmly attached while the motorhome is in transit. The driver should adjust his seat so that he is able to reach all controls easily with the belt on, especially able to use all the travel on the foot brake. The belt should be placed as low as possible around the hips to prevent sliding out from under them in case of accident. This places the load of the body on the strong hipbone structure instead of around the soft abdominal area. Two people should never try to use the same seat belt.



Warning: Children must be secured in a Federally Approved Child Restraint Device. Failure to use proper restraints while in transit can result in severe or fatal injuries.

Child restraint devices are designed to be secured with lap or lap/shoulder belts. All instructions supplied by the restraint manufacturer must be followed. Statistics have shown children are safer when properly restrained in a rear seating position than in a front seating position.

Often the children traveling in motorhomes are grandchildren. There are times when our love for grandchildren makes us hesitate to properly supervise their actions. Don't hesitate when it comes to their safety. Make sure they are properly restrained.

CHILDREN HAVE LOVED ONES TOO.

IF YOU WON'T BUCKLE UP FOR YOURSELF, BUCKLE UP FOR THEM.

DRIVING

DASH SWITCHES

- **Door Lock** -The main door can be locked or unlocked from the drivers seat. Remember to hide an extra door key on the exterior in case of unexpected battery failure.
- **Auxiliary Start** - The auxiliary start switch is intended to be used if the engine battery becomes too discharged to turn the engine over. To operate, hold the switch in the start position, and then use the ignition switch in a normal fashion. Operating the auxiliary start switch closes the points on a large solenoid, tying all three-vehicle batteries together for increased starting power.
- **Generator Switch** - The remote generator switch on the dash allows the driver to start or stop the generator without leaving the driver's seat. It should be noted a built-in time delay allows the generator to reach full operating speed before 120 volt current is provided to the coach.
- **Rear Heat** – (30 ft & 33 Ft. only) this switch is two speeds and controls the fan on the rear engine heater by the door. The heat source is from the radiator so heat will only be available when driving.
- **Rear Camera** – (option 26 Ft.) the rear view-monitoring camera has two positions. One will show the rear bumper and operating the switch tilts the camera to view further back.
- **Auxiliary Head Lights** - To operate the auxiliary lights the regular headlights must be turned on first.
- **Defrost Fans** - (option) In cool, damp weather these fans really help to clear the large windshields. This switch turns them on and off and each fan has its own switch to operate the oscillating feature.
- **Aisle Lights** - The low aisle lights will allow passengers to converse without using overhead lights that could be bothersome to a driver at night.
- **Docking Lights** - (option 26 Ft.) the docking lights illuminate the area at the side of the motorhome and are intended for use when parking in a campground at night.
- **Inverter** – (option) This switch controls a relatively small Inverter wired into the front television. Turn the switch on when you want to watch the front television and you're not plugged into 110-volt power.
- **Rear Monitor** - (option 26 Ft.) when the ignition key is turned to the accessory or ON position, the power will be supplied and the monitor will be in the standby condition.
When you set the gear lever to the R (reverse) position with the POWER switch released (STANDBY), the monitor will be automatically turned on and the picture will be displayed on the monitor. To see rearview when not in reverse, depress the power button to ON.
Please review the rearview monitor manual placed in your Silver Key notebook.

ARMREST SWITCHES

- **Exterior Mirrors** - Move center switch to R or L. The four perimeter switches will then move the right or left mirror in the direction indicated. Toggle switch operates heat.
- **Power Window** – Located above the armrest, operates the driver's window.

DRIVING

CAB SEATS

Besides the normal power seat control there are two additional finger levers. One allows the seat to recline and the other will let the seat rotate.

CAUTION: Revolving the power seat completely around will pull the wiring apart. The seats should only be swiveled toward the center of the vehicle. If the wires are loosened, following the color code can reconnect them: Red to red, green-to-green, etc. On some models the wires will be on a plug that can be reattached.

TRAILER TOWING AND DRIVING TIPS

Since this vehicle is designed and intended to be used primarily as a load-carrying vehicle, towing a trailer will affect handling, durability and economy. Maximum safety and satisfaction depends upon proper use of correct equipment and avoiding overloads and other abusive operation.



Warning: The total weight of the motorhome and trailer must not exceed the GCWR listed in the specification section of this manual. The maximum towing capacity varies according to the size of the motorhome and its GCWR. Vehicles should be properly equipped for towing trailers. Information on trailer hauling capabilities and special equipment required may be obtained from your Airstream dealer.

To assist in attaining good handling of the vehicle/trailer combination it is important that the tongue load be maintained at approximately 10% of the loaded trailer weight, but not to exceed the hitch rating. Tongue loads can be adjusted by proper distribution of the load in the trailer, and can be checked by weighing separately the loaded trailer and then the tongue.

When towing trailers, motorhome tires should be inflated to the highest pressures shown on the information plate attached to the dash of your motorhome. The Cargo Carrying Capacity (CCC) of this vehicle is reduced by the amount that equals the trailer tongue load on the trailer hitch.



Warning: The towing vehicle's braking system is rated for operation at GVWR (GROSS VEHICLE WEIGHT RATING), NOT at the GCWR (GROSS COMBINED WEIGHT RATING). A separate functioning brake system is required for any towed vehicles or trailers weighing more than 1000 lbs. (450 kg) when fully loaded. NEVER exceed the GVWR (GROSS VEHICLE WEIGHT RATING), or the GAWR (GROSS AXLE WEIGHT RATING) specified on a motorhome certification label. Also NEVER exceed the weight ratings of trailer hitch installed on a motorhome. Failure to heed any part of this warning could result in loss of control of the motorhome and towed vehicle or trailer and may cause an accident and serious injury. For specified towed vehicle braking requirements, consult the chassis owner's manual that comes with this vehicle.

CAUTION: Considerable damage will occur if the motorhome is improperly lifted for towing purposes. Only qualified professional wrecker service companies with proper equipment should be used.

The most common equipment is called "reach under hooks". These allow the tow operator to lift on the front suspension of your motorhome without damaging the bumper or other body parts. Another choice is a wheeled dolly. In these the front tires sit in a cradle supported by its own wheels. The tow operator should be told the weight of your vehicle is close to 5,000 lbs. on the front suspension so they can be properly prepared when they reach you.

On vehicles with hydraulically operated park position, it may be necessary to remove a drive shaft before towing. Further information is available in your Chassis Owners Manual.

DRIVING

Procedure for Weighing A RV

Vehicle should be weigh loaded as you normally travel.

1. Fill in first row from Specification Section of this manual.
2. Weigh vehicle as shown in row 2 (Scale Weight) and fill in blanks.
3. Weigh one side of vehicle as shown In Individual Wheel Position Weight.
4. Calculate other side as shown in Last

Information for line 1 is located in the specification section in this manual.

Front Axle GAWR	GVWR	Rear Axle GAWR	GCWR - GVW
--------------------	------	----------------	------------

SCALE WEIGHT

Optional Tow Weight



STEP 1
Front Axle GAW



STEP 2
GVW



STEP 3
Rear Axle GAW



STEP 3a
Tow Weight minus
Weight of Trailer
or Vehicle Towed

INDIVIDUAL WHEEL POSITION WEIGHT

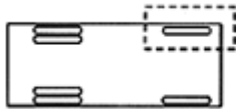

STEP 4
Left Front Wheel
Position

Calculated

Right Front Wheel
Position
Step 1 minus Step 4

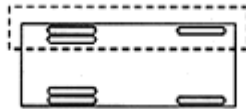

STEP 5
Left Side
(Total LF + LR)

Calculated

Right Front
(Total RF + RR)
Step 2 minus Step 5



STEP 6
Left Rear Wheel
Position

Calculated

Right Rear
Wheel Position
Step 3 minus Step 6

GAWR = Gross Axle Weight Rating
 GVWR = Gross Vehicle Weight Rating
 GCWR = Gross Combination Weight Rating

CHASSIS

The Airstream motorhome is built on a chassis designed for motorhomes. Operation of the engine and other related components is discussed in the Chassis Owners and Drivers Manual supplied with each coach.

If repairs are needed it can be difficult to determine which parts are the chassis, and which are Airstream's responsibility. The following list shows the major components of the chassis and the company responsible for their servicing.

Motorhome Chassis Serviced By Work Horse Custom Chassis.

Roadside Assistance: 1-877-946-7731 (24-7) See Chassis Owner's Manual

Engine	Turn Signals
Transmission	Suspension, including Front Air Cylinders
Brakes	Drive Axle and Hubs
Steering Assembly	Rear Shocks
Front Spindle, Bearings	Automotive Fuse Panel
Steel Wheels	Parking Brake
Alternator	Electric Fuel Pump
Cruise Control	Engine Battery
Instrument Panel Cluster	Engine Cooling System
Tires (see tire manufacturer service center)	

Airstream

Auxiliary Heater	Leveling Jacks
*Dash Air Conditioner/Heater	Coach Batteries
Windshield Wipers	Battery Control Center (Intellitec)
Hitch (REESE)	Windshield Wipers

*The warranty on the dash air conditioner/heater can be confusing. The chassis manufacturer provides and installs the air conditioning compressor, condenser, dryer, dual cooling fans and associated plumbing. Airstream provides and installs the blower, evaporator, dash control, heater core and heater hoses. All venting and duct work is Airstream's.

The above list covers almost all of the chassis components. If you need further clarification or information contact the Airstream Customer Relations Department at 937-596-6111. If you wish to write the address is:

Airstream Inc.
419 W. Pike Street
P.O. Box 629
Jackson Center, Ohio 45334

CHASSIS

DASH AIR CONDITIONER/HEATER

Specific Climate Systems Inc.
1200 West Risinger Road
Fort Worth, Texas
Technical Assistance: 1-800-275-7524

OPERATION

The dash heater control is very similar to many automobiles

The center rotary switch marked "cold-hot" controls the amount of hot water flowing through the heater core. When the maximum air conditioner is engaged, inside air is circulated through the evaporator to obtain the utmost in cooling. The two positions marked vent and norm draw outside air through the evaporator.

SERVICE

Automotive Air conditioning has become a very specialized business requiring specific training and refrigerant disposal certifications. SCS has requested you to contact them on the toll free number listed above should you experience any service problems. Please contact SCS immediately if a warranty situation develops that your local dealer is unable to solve. They will authorize repairs and assist the dealer and if necessary aid you in obtaining service at an authorized air conditioner repair facility close to your location. This service locator assistance can be especially helpful if you are traveling and an Airstream dealer is unavailable or a considerable distance away.

CHASSIS

AUXILIARY HEATER (Option 26 Ft.)

The auxiliary heater, located under the coach near the step, is plumbed into the radiator system. Two "tees" are located between the engine and the front heater. The water lines to the heater are routed under the floor. By using the two-speed dash fan the temperature output can be varied.

TIRES

Your chassis Owner's Manual contains important cautions and information on tires and should be reviewed and followed for your safety.

The tires installed on your Airstream motorhome are engineered to provide a proper balance of performance characteristics for normal vehicle operation.

This section contains some tips on how you can obtain the most benefit from these tires.

Don't let anyone tell you that under inflation or over inflation is all right. It's not. If you're tires don't have enough air (underinflation) you can get tire flexing, heat build-up, tire overloading, bad handling, bad fuel economy, and bad wear. Too high an air pressure (over inflation) can result in abnormal wear, bad handling, harsh ride, and also increase the chance of damage from road hazards.

Tire inflation pressures should be checked at least monthly and when significantly changing the load you plan to carry in your motorhome. Always check tire inflation pressures when the tires are "cold". **See tire inflation on page C-9.**

Standard inflation pressures for tires are listed in the " Cold Inflation Pressure" chart. Front and rear pressures are shown for each model and GVWR, and are based on the GVWR and front and rear axle ratings (GAWRs) printed on your vehicle VIN plate and Certification label. Tires must be inflated to these pressures when the vehicle is fully loaded or an axle GAWR is reached.

Cold Inflation Pressure (PSI)

Model	Tire Size	Front	Rear Duals
26 ft. 15,000 GVWR	225/70R x 19.5F	80 psi	90 psi
30 ft. 18,000 GVWR	225/70R x 19.5F	80 psi	90 psi
33 ft. 18,000 GVWR	225/70R x 19.5F	80 psi	90 psi

CHASSIS

Proper FRONT END ALIGNMENT improves tire tread mileage. Your front-end suspension parts should be inspected periodically and aligned when needed. Improper alignment may not cause the vehicle to vibrate. However, improper toe alignment will cause front tires to roll at an angle, which will result in faster tire wear. Incorrect caster or camber alignment will cause your front tires to wear unevenly and can cause the vehicle to "pull" to the left or right.

The chassis front air bags should be inflated as instructed in chassis owner's manual and checked monthly.

Caution: Chassis manufacturer urges each owner to have the front end alignment checked after they have loaded the motorhome as they would on a trip.

WHEEL COVER

The new wheel covers on our motorhomes are removed by pulling off two of the lug nut covers. The two (of ten) loose ones are identified by indentations on three sides to hold them on the nut, and there are no flanges. You will have to look close the first time to find them. Once the nut covers are pulled off, the lug nut extension holding the wheel cover in place is easily removed.

TIRE CHANGING

Caution: Changing a tire on a heavy-duty motorhome chassis is a physically demanding procedure. It requires specialized tools and knowledge of safety procedures. Only you can determine your knowledge base and physical ability. Don't take any unnecessary risks. You could turn an inconvenience into a tragedy. Please find a safe area to park your unit, call a tire service center and supply them with the information below if you have any doubts about changing a tire.

The spare tire is located in the trunk storage compartment on the 26 Ft model and tucked up under the trunk storage area against the bottom of the floor on the 30 & 33 Ft. models.

Remove the spare from the 26' coach by sliding it out the rear trunk door. The 30' & 33' models use a winch to lower and raise the spare tire. The winch is accessed inside the trunk storage area. To remove the spare tire, use a ratchet or speed wrench with a socket to lower the spare to the ground. Block the tire up to remove the weight from the washer, remove the washer from the yoke, slide the yoke through the rim, and slide the tire from under the motorhome.

To store a spare tire reverse the removal instructions.



Warning: Defective spare tire equipment or an improperly stored spare tire could damage your equipment and/or cause serious injuries to people inside your motorhome, other motorists and pedestrians. The yoke, washer, and spare tire must be placed in the proper order to achieve safe storage as you travel. The cable and support system must be free from defects and in good working order. The complete system should be checked before each trip and every 1000 miles during a trip for any signs of wear or possible failure. Please contact your dealer or Airstream Customer Service if you have any questions on the use of this equipment.

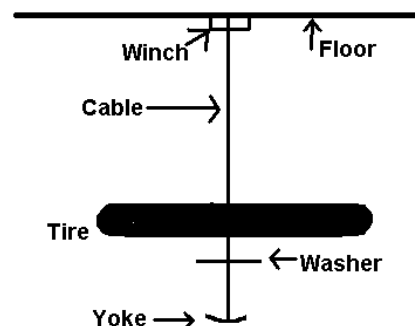

CHASSIS

TIRE CHANGING (cont)

When removing a steel wheel rim to change a tire, loosen all wheel nuts approximately flush with end of stud, then tap clamp ring to loosen rim. Do not remove nuts until clamp rings are free or clamp ring may fly off of stud. When installing rim be sure pins on clamp ring face outboard. Then tighten attaching nuts alternately and evenly to avoid excessive wheel run-out. See torque values and sequence diagram. See **tire inflation warning on page C-9.**

LUG NUT TIGHTENING



Warning: WHEN A UNIT IS NEW, OR WHEN EVER A WHEEL, WHEEL BOLT, OR WHEEL NUT IS REPLACED THE WHEEL NUT TORQUE MUST BE CHECKED AT 100, 1,000 AND 6,000 MILES, AND EVERY 6,000-MILES THEREAFTER.

TIGHTENING SEQUENCE

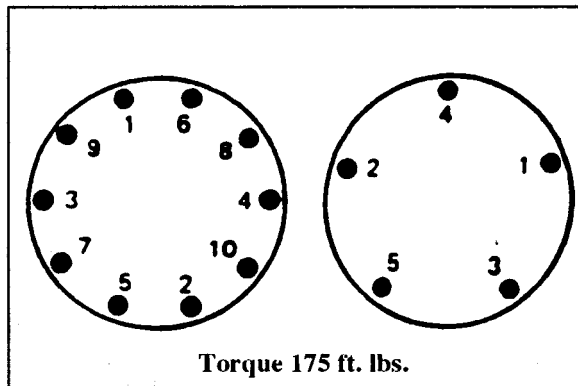

JACK PLACEMENT

Place the jack under the control arm to change front tires. Place the jack under the dual wheeled axle close to the tires being changed for rear tires on dual-wheeled axles.

CHASSIS

TIRE ROTATION

Front and rear tires perform different jobs and can wear differently depending on the types of roads driven, your driving habits, etc. To obtain the longest tire life you should **INSPECT AND ROTATE** your tires regularly. (See Tire Rotation Illustration below).

Many automotive dealers and tire dealers will perform a free tire inspection to look for uneven or abnormal tire wear.

Tires should be rotated every 6,000 to 8,000 miles. For the longest tire life, any time irregular wear is seen have the tires checked, alignment checked, and tires rotated by your truck or tire dealer. Have the cause of uneven wear corrected.

The outer tire of a pair in dual wheel installations generally wears faster than the inner tire. When vehicles are driven continuously on high crown roads, an increase in air pressure of 5 psi on the outside tire of each dual produces maximum tire life. Be sure to return to recommended pressure when no longer driving under these conditions.

After rotation be sure to check wheel nut tightness and to adjust the tire pressures, front and rear.

See tire inflation warning on page C-9.



Warning: Wheel nuts should be tightened at certain intervals. See Lug Nut Tightening on previous page of this manual and read your chassis manual on this subject.

FOR SAME BRAND, LOAD RANGE AND TREAD PATTERN ON ALL TIRES

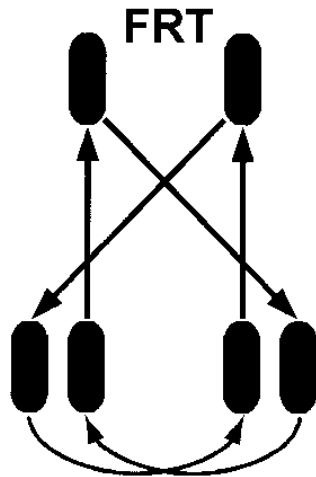

FRONT AND REAR

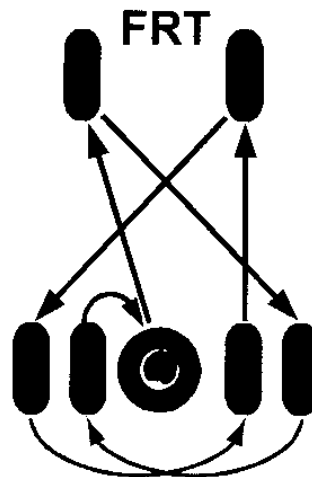

FRONT, REAR, AND SPARE

CHASSIS

TIRE SUPPORT

Since motorhomes may sit for long periods of time it is important to properly support the tires if blocks are used for leveling.

The following information is provided by the Michelin Technical Group.

Extreme caution must be taken to ensure that the tires are fully supported when using blocks to level motorhomes and/or RV's. The load on the tire should be evenly distributed on the block and in the case of duals, evenly distributed on blocks for both tires. If not properly done, the steel cables in the sidewall of the tires may be damaged and could lead to premature fatigue of the sidewall.

The **CORRECT** methods are shown in Figure 1. Please note that the blocks are wider than the tread and longer than the tire's footprint. This provides maximum support to the tires and assures that the load is evenly distributed throughout the tire's footprint area.

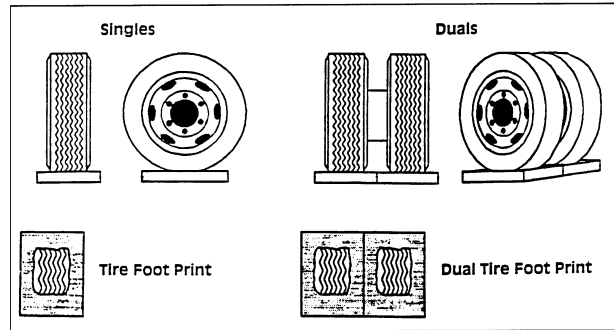

F
FIGURE 1
CORRECT

CHASSIS

INCORRECT

One tire or a portion of one tire is supporting the full load.

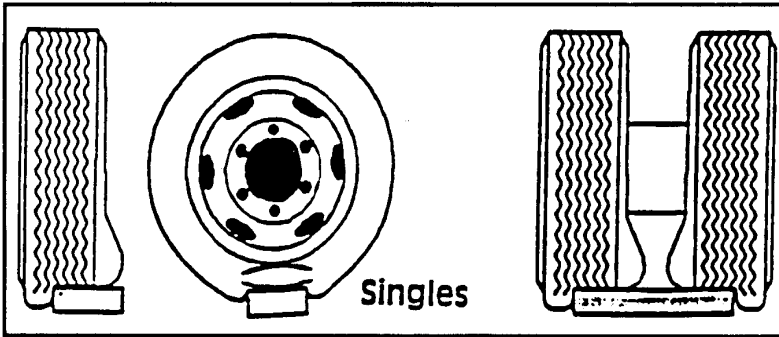
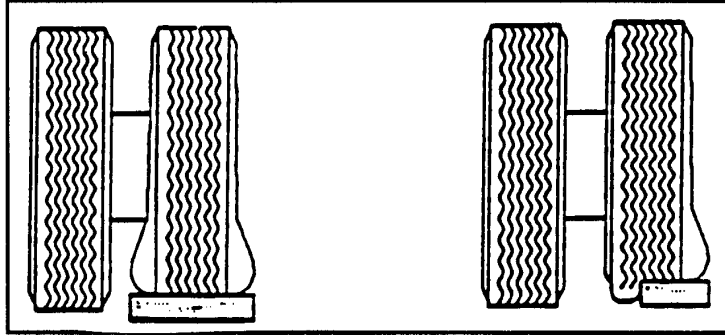

Portion of two tires are supporting the full load.

CAUTION: Tires incorrectly supported, as shown above, may be damaged which could lead to casing failure resulting in serious injury or property damage. If, on previous occasions, the tires have been incorrectly supported, a hidden damage may be present. Please contact your local Michelin dealer and request an inspection and a determination of possible damage.

CHASSIS

TIRE INFLATION INFORMATION



Warning: Your vehicle is equipped with a tire that is an all-steel radial. All-steel radial tires utilize steel cords in the sidewalls, and also require increased inflation pressures. As such, they cannot be treated like normal light truck tires. Personnel trained, supervised and equipped according to Federal Occupational Safety and Health Administration (OSHA) regulations must perform tire service, including adjusting tire pressure. For example, during a procedure involving tire inflation, the technician or individual must utilize a remote inflation device, and insure that all persons are clear of the trajectory area.

An inflated tire and rim can be very dangerous if improperly used, serviced, or maintained. To avoid serious injury, never attempt to re-inflate a tire which has been run flat or seriously under inflated without first removing a tire from the wheel assembly for inspection. Do not attempt to add air to tires or replace tires or wheels without first taking precautions to protect persons and property.

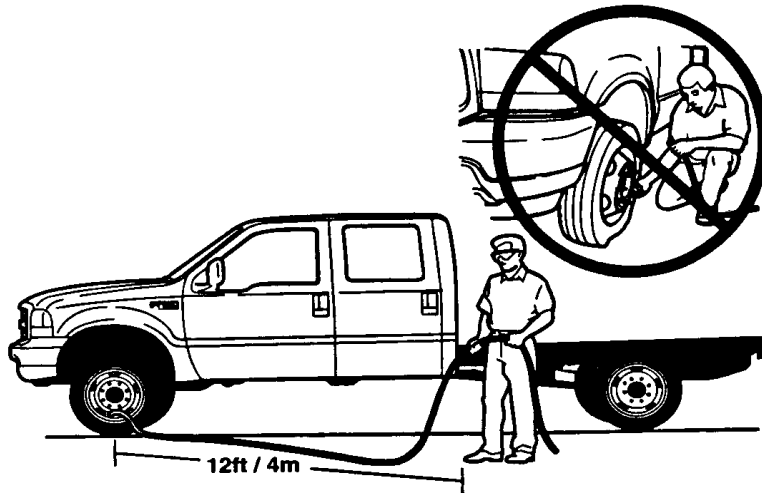

CHASSIS

ELECTRIC STEP (KWIKEE STEP SERIES 28)

Manufacturer:

Kwikee Products Company
Division of Ashton Corporation
P.O. Box 638
Drain, Oregon 97435
Phone: 503-836-2126

The step is easy and convenient to operate. Just inside the main door is a wall switch for the step. When traveling, leave the switch in the "ON" position - the step will lower when the door is opened and retract when the door is closed.

When parked, open the door so the step is lowered, then shut the switch off. The step will remain in the lowered position and the "step" light on the dash will be extinguished.

If you forget and leave the switch off as you leave - No Problem! When the ignition is "ON" the wall switch is by-passed and the step will retract when the door is closed.



Warning: If the wall switch is turned off, and the step is in the retracted position when the ignition is turned off, the step will not lower when the door is opened. Keep your passengers informed.

CHASSIS

MAINTENANCE AND LUBRICATION

Clean all mud, salt, and road grime from step before lubricating. Lubricate all moving parts (bearings, pivot points, slides, clevis pin, and drive linkage ball) every 30 days with a good quality moisture and heat resistant penetrating grease. Kwik-Lube Spray Grease is specially formulated to lubricate Kwik-ee Electric Steps and is recommended for lubricating all moving parts. Refer to the figures below for lubrication locations.

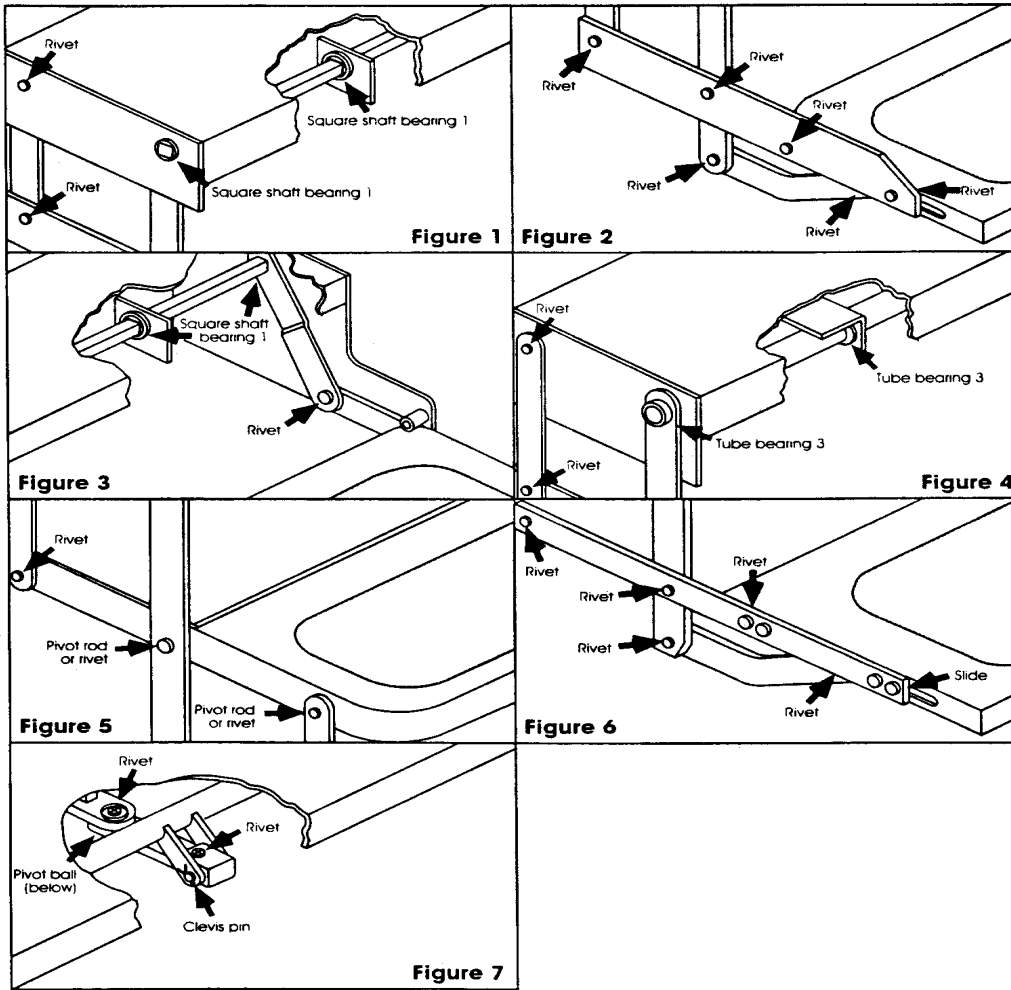

NOTE: Figures are to be used as a general reference only. Some may not pertain to your particular step model. Views are typical to both ends of the steps.

1. Figures 1 & 3 - square shaft bearing - lubricate around outside and under head of bearing.
2. Figure 4 - on step models equipped with plastic cover, this cover will have to be removed to lubricate center bearings. Lubricate bearings under cover every 90 days.
3. Figure 4 - 1" O.D. tube bearing - lubricate around drive tube and between head of bearing and drive leg.

NOTE: We recommend that penetrating oils and silicone lubricants not be used on the step as they do not last.

CHASSIS

NOTES

CAMPING

SAFETY:

As always, safety should be one of your top priorities. Make sure you, and everyone traveling with you, can operate the main door and exit window rapidly without light.



Warning: The roadside rear window is designed as an escape window. To escape, pull in on the two red latches at the bottom. The complete window sash will swing out to allow easy exit. The pleated shade is opened by sliding straight up. The window operation should be checked each trip and explained to all traveling companions.



Warning: At each campsite make sure you have not parked in such a manner as to block the operation of the escape window by being too close to trees, fences or other impediments. Scenic views are one reason for traveling, but don't park so the beautiful lake or steep cliff is just outside your escape window.



Warning: Read the directions carefully on the fire extinguisher. If there is any doubt on the operation, you and your family should practice, then replace or recharge the extinguisher. You will find your local fire department will be happy to assist you and answer any questions.



Warning:
DON'T SMOKE IN BED!
KEEP MATCHES OUT OF REACH OF SMALL CHILDREN!
DON'T CLEAN WITH FLAMMABLE MATERIAL!
KEEP FLAMMABLE MATERIAL AWAY FROM OPEN FLAME!

We have all heard these warnings many times, but they are still among the leading causes of fires.

Other safety information on the LPG system of your motorhome is located in the Plumbing Section of this manual.

SMOKE ALARM

OPERATION, TESTING

OPERATION: The smoke detector is operating once a fresh battery is installed and testing is complete. When products of combustion are sensed, the unit sounds a loud 85 db pulsating alarm until the air is cleared.

HUSH CONTROL: The "HUSH" feature has the capability of temporarily desensitizing the alarm circuit for approximately 7 minutes. This feature is to be used only when a known alarm condition, such as smoke from cooking, activates the alarm. The smoke detector is desensitized by pushing the "HUSH" button on the smoke detector cover. If the smoke is not too dense, the alarm will silence immediately and "Chirp" every 30-40 seconds for approximately 7 minutes. This indicates that the alarm is in a temporarily desensitized condition. The smoke alarm will automatically reset after approximately 7 minutes and sound the alarm if particles of combustion are still present. The "HUSH" feature can be used repeatedly until the air has been cleared of the condition causing the alarm.

NOTE: DENSE SMOKE WILL OVERRIDE THE HUSH CONTROL FEATURE AND SOUND A CONTINUOUS ALARM.

CAMPING

CAUTION: BEFORE USING THE ALARM HUSH FEATURE, IDENTIFY THE SOURCE OF THE SMOKE AND BE CERTAIN A SAFE CONDITION EXISTS.

FLASHING L.E.D. LIGHT: This smoke detector is equipped with a flashing red indicator light. The light is located under the test button and will flash every 30-40 seconds to indicate that the smoke detector is receiving power.

TESTING: Test by pushing the test button on the cover and holding it down for a minimum of 2 seconds. This will sound the alarm if all the electronic circuitry, horn and battery are working. If no alarm sounds the unit has defective batteries or other failure. You can also test the alarm by blowing smoke into it.

TEST THE ALARM WEEKLY TO ENSURE PROPER OPERATION. Erratic or low sound coming from your alarm may indicate a defective detector, and it should be returned for service.

FALSE ALARMS

Smoke detectors are designed to minimize false alarms. Cigarette smoke will not normally set off the alarm, unless the smoke is blown directly into the detector. Combustion particles from cooking may set off the alarm if the detector is located close to the cooking area. Large quantities of combustible particles are generated from spills or when broiling. Using the fan on a range hood which vents to the outside (non-recirculating type) will also help remove these combustible products from the kitchen. **MODEL 0916 HAS A "HUSH" CONTROL** that is extremely useful in a kitchen area or other areas prone to nuisance alarms.

For more information refer to **OPERATION AND TESTING.**

If the detector does alarm, check for fires first. If a fire is discovered, get out and call the fire department. If no fire is present, check to see if other reasons may have caused the alarm.

MAINTENANCE

BATTERY REPLACEMENT

To replace-the battery remove the detector from the mounting plate by rotating the detector in the direction of the "OFF" arrow on the cover.

The Model 0916 Smoke Detector uses one (1) 9-volt battery. The **SMOKE DETECTOR** is powered by a 9V carbon zinc battery (alkaline battery may also be used). A fresh battery should last for one year under normal operating condition. This detector has a low battery monitor circuit that will cause the detector to "chirp" approximately every 30-40 seconds for a minimum of seven (7) days when the battery gets low. Replace the battery when this condition occurs. ***USE ONLY THE FOLLOWING 9 VOLT BATTERIES FOR SMOKE DETECTOR REPLACEMENT***

Carbon-zinc type: EVEREADY 216 OR 1222, GOLD PEAK 1604P OR 1604S

Alkaline type: EVEREADY 522; DURACELL MN 1604, Gold Peak 1604A

Lithium type: ULTRALIFE U9VL. NOTE:

REGULAR TESTING IS RECOMMENDED.



WARNING USE ONLY THE BATTERIES SPECIFIED. USE OF DIFFERENT BATTERIES MAY HAVE A DETRIMENTAL EFFECT ON THE SMOKE DETECTOR.

NOTE: IF AFTER BATTERY REPLACEMENT, THE UNIT CONTINUES TO CHIRP, WAIT FOR APPROXIMATELY 7 MINUTES. THE "HUSH" FEATURE MAY HAVE BEEN ACTIVATED ACCIDENTALLY WHILE CHANGING THE BATTERIES AND WILL RESET AUTOMATICALLY

CAMPING

CLEANING YOUR DETECTOR:

To clean your detector remove it from the mounting bracket as outlined in the beginning of this section.

You can clean the interior of your detector (sensing chamber) by using your vacuum cleaner hose and vacuuming through the openings around the perimeter of the detector.

The outside of the detector can be wiped with a damp cloth.

AFTER CLEANING, REINSTALL YOUR DETECTOR. TEST YOUR DETECTOR BY USING THE TEST BUTTON.

LIMITATIONS OF SMOKE ALARMS:



WARNING Smoke detectors are devices that can provide early warning of possible fires at a reasonable cost; however, detectors have sensing limitations. Ionization type detectors offer a broad range of fire sensing capability but are better at detecting fast flaming fires than slow smoldering fires. Photoelectric detectors sense smoldering fires better than flaming fires. Home fires develop in different ways and are often unpredictable. Neither type of detector (photoelectric or ionization) is always best, and a given detector may not always provide warning of a fire. Also, smoke detectors do have limitations. For a battery powered detector the battery must be of the specified type, in good condition, and installed properly. AC powered detectors will not operate if AC power has been cut off such as by an electrical fire or an open fuse. Smoke detectors must be tested regularly to make sure the batteries and the detector circuits are in good operating condition.

Smoke detectors cannot provide an alarm if smoke does not reach the detector. Therefore, smoke detectors may not sense fires starting in chimneys, walls, on roofs, on the other side of a closed door or on a different floor. If the detector is located outside the bedroom or on a different floor, it may not wake up a sound sleeper. The use of alcohol or drugs may also impair ones ability to hear the smoke alarm. For maximum protection a smoke detector should be installed in each sleeping area on every level of a home.

Although smoke detectors can help save lives by providing an early warning of a fire, they are not a substitute for an insurance policy. Homeowners and renters should have adequate insurance to protect their lives and property.

GOOD SAFETY HABITS

DEVELOP AND PRACTICE A PLAN OF ESCAPE:

- Make a floor plan indicating all doors and windows and at least two (2) escape routes from each room. Second story windows may need a rope or chain ladder.
- Have a family meeting and discuss your escape plan, showing everyone what to do in case of fire.
- Determine a place outside your home where you all can meet if a fire occurs.
- Familiarize everyone with the sound of the Smoke Alarm and train him or her to leave your home when they hear it.
- Practice a fire drill at least every six months. Practice allows you to test your plan before an emergency; you may not be able to reach your children. *It is important they know what to do.*

CAMPING

WHAT TO DO WHEN THE ALARM SOUNDS:

- Leave immediately by your escape plan. Every second counts, so don't waste time getting dressed or picking up valuables.
- In leaving, don't open any inside door without first feeling its surface. If hot, or if you see smoke seeping through cracks, don't open that door! Instead use your alternate exit. If the inside of the door is cool, place your shoulder against it, open it slightly and be ready to slam it shut if heat and smoke rush in.
- Stay close to the floor if the air is smoky. Breathe shallowly through a cloth, wet if possible.
- Once outside go to your selected meeting place and make sure everyone is there.
- Call the fire department from your neighbor's home - *not from yours!*
- Don't return to your home until the fire officials say that it is all right to do so.

There are situations where a smoke detector may not be effective to protect against fire as stated in the NFPA standards 72.

For instance:

- a) Smoking in bed;
- b) Leaving children home alone.
- c) Cleaning with flammable liquids, such as gasoline.

Further information on fire safety can be obtained in a pamphlet titled "IN A FIRE SECONDS COUNT" published by the NFPA, Batterymarch Park, Quincy, Mass. 02269.

SERVICE AND WARRANTY

If after reviewing this manual you feel that your smoke alarm is defective in any way, do not tamper with the unit. Return it for servicing to: FYRNETICS, INC., 1055 STEVENSON CT./STE 102W, ROSELLE, IL 60172. (See Warranty for in-warranty returns).

CARBON MONOXIDE ALARM

The following information is highlights from the folder provided by the alarm manufacturer. The folder, with more detailed information, is contained in your Owners' Packet.

Test detector immediately following installation and weekly for proper operation by pushing the test button until the YELLOW L.E.D. lights and a short beep is heard (approximately three seconds). Release the button. The detector will then test itself for proper operation. At completion of the self-test, the alarm will sound and both L.E.D.s will light for 3/4 of a second. The detector then resumes normal operation.

NORMAL OPERATION

In normal operation the detector will flash the RED L.E.D. once every 30 seconds.

WARNING CONDITION

If the COSTAR senses a low level of CO The YELLOW L.E.D. will light and the detector will beep every three seconds warning that CO is present. The area should immediately be ventilated. A concentration of 60 PPM within 67 minutes will cause the warning condition. Pushing the test button will silence the warning signal but the YELLOW L.E.D. will stay on. After two hours the warning signal will sound again if the CO source has not been eliminated. If the condition persists there is a possibility that it may cause the unit to enter alarm condition (below). If this occurs pushing the reset button will silence the alarm for 30 minutes.

CAMPING

ALARM CONDITION

If the COSTAR senses unsafe levels of CO, the RED L.E.D. will light up and the alarm will sound. The alarm condition will be signified by a repetitive alarm-sounding pattern of approximately 4.5 seconds on 1.5 second off. **Immediate evacuation is required.** Pushing the test button will silence the alarm once for approximately 4 minutes.

After approximately 4 minutes the alarm will once again sound until the unsafe CO concentration is removed.

FAULT CONDITION

Periodically the detector's measurement circuit is tested. If an error is detected, the detector will sound twice and the YELLOW L.E.D. will flash twice every 30 seconds. This is an indication of circuit malfunction and that the detector requires immediate servicing.

MAINTENANCE

Battery Replacement:

If tamper resistant pin has been used, refer to "tamper resistant locking pin" for removal instructions.

To replace the battery remove the detector from the mounting plate by rotating the detector in the direction of the "OFF" arrow on the cover.

The **Model 9L-1 CO Detector** uses one (1) 9-volt battery. The **CO DETECTOR** is powered by a 9V alkaline battery. A fresh battery should last for one year under normal operating conditions. This detector has a low battery monitor circuit which will cause the detector to "chirp" and the red LED to flash approximately every 30-40 seconds for a minimum of seven (7) days when the battery gets low. Replace the battery when this condition occurs. **USE ONLY THE FOLLOWING 9 VOLT BATTERIES FOR CO DETECTOR REPLACEMENT.**

Alkaline type: EVEREADY522; DURACELL MN1604; GOLD PEAK 1604A

Lithium type: ULTRALIFE U9VL

NOTE: REGULAR TESTING IS RECOMMENDED.



Warning: USE ONLY THE BATTERIES SPECIFIED. USE OF DIFFERENT BATTERIES MAY HAVE A DETRIMENTAL EFFECT ON THE CO DETECTOR.

CLEANING YOUR DETECTOR:

To clean your detector remove it from the mounting bracket as outlined in the beginning of this section. You can clean the interior of your detector by using your vacuum cleaner hose and vacuuming through the openings around the perimeter of the detector. The outside can be wiped with a damp cloth.

AFTER CLEANING, REINSTALL YOUR DETECTOR. TEST YOUR DETECTOR BY USING THE TEST BUTTON.

Test detector weekly for proper operation by pushing the test button until the YELLOW L.E.D. lights and a short beep is heard (approximately three seconds). Release the button. The detector will then test itself for proper operation. At completion of the self-test, the alarm will sound and both L.E.D.s will light for 3/4 of a second. The detector then resumes normal operation.

CAMPING

SERVICE AND WARRANTY

If after reviewing this manual you feel that your CO Detector is defective in any way, do not tamper with the unit. Return it for servicing to: **Quantum Group, Inc., 11211 Sorrento Valley Road, Suite Valley Road, Suite V. San Diego, CA 92121.** Or call us toll free (800) 432-5599 E-mail address: mktsls@qginc.com

LP GAS DETECTOR

In the kitchen area of your unit, approximately six inches above the floor, is the LP gas detector. LP gas is a mixture of gases produced and sold commercially as a fuel for heating and cooking appliances. LP gas is highly flammable and, as a result, can be explosive if ignited under certain circumstances. LP gas is heavier than air and, if confined in a closed space, will accumulate close to the floor. When the LP gas concentration in your unit exceeds 2000 PPM the detector will provide a visual and audible alarm by sounding a buzzer and flashing the red LED two times per second.



Warning: Activation of this detector indicates the presence of LP gas, which can cause an explosion and/or fire. This normally indicates a leak in the LP gas installation or a LP gas appliance. Extinguish all open flames, open your windows and door and evacuate the unit immediately. Do not activate any electrical switch. Turn off the LP at your gas bottle(s). **DO NOT RE-ENTER YOUR UNIT UNTIL A QUALIFIED REPAIR TECHNICIAN HAS CORRECTED THE PROBLEM.**

OPERATION

Your LP gas detector is wired directly to your vehicle battery and incorporates a 1-amp in-line fuse. When the device is operating normally the green LED will be lit.

CAUTION: It is not recommended that the detector be disconnected from the battery during periods of storage. There is a small heater on the sensor of the device, which "burns" away impurities in the air during periods of normal use. During periods when power is interrupted, impurities can build up on the sensor. When power is returned to the detector the detector alarm may activate until the impurities are "burned" off. This could take a number of hours, during which time the alarm will be constantly "on".

DETECTOR TEST

Press the test button for 5 to 6 seconds until the alarm sounds then release the test button. The red LED should flash and the alarm sound for approximately 4 minutes. This test should be performed at least once a week during normal vehicle operation, and after periods of storage, and before each trip.

LOW VOLTAGE

Below 10 VDC the detector will continue to operate but will blink alternately green and orange. Below 8 VDC the unit will behave erratically and will eventually shut off. To ensure proper operation, do not operate the unit below 10 VDC.

COMPONENT FAILURE

The failure of any circuit component will cause the detector to display a continuous orange LED fault light and a short beep indicating failure. If this occurs, immediately contact your dealer or Airstream Customer Service for the name of the nearest detector service center.

Please read the operating instructions for your detector, which have been supplied with the paper work of your unit.



Warning: Have a professional technician check all safety related systems yearly or whenever any doubts of their ability to function properly arise.

CAMPING

OVERNIGHT STOP

In time you will develop a knack for spotting wonderful little roadside locations by turning off the main highway and exploring. There are many modern recreational vehicle parks, including State, County and Federal parks with good facilities, where you may obtain hookups of electrical, water and sewer connections. Directories are published which describe in detail these parks and tell what is available in the way of services and hookups.

All you need to do to enjoy the self-contained luxury is to:

1. Turn on LP gas supply and light appliance pilots if required.
2. Turn on water pump and open faucets until air is expelled from the system.

Before moving on, turn off the LP gas and water pump, check your campsite, both for cleanliness and also to be sure you haven't left anything behind. Make sure everything is properly stowed.

Overnight or Weekend Trips

On overnight or weekend trips, chances are you will not use up the capacity of the sewage holding tank, deplete the water supply, or run down the batteries which supply the living area 12 volt current.

Longer Trip

On a longer trip, when you have stayed where sewer connections and utility hookups were not available, it will be necessary for you to stop from time to time to dispose of the waste in the holding tank and replenish the water supply. Many gas stations (chain and individually owned) have installed sanitary dumping stations for just this purpose. Booklets are available which list these dumping stations.

When you stop for the night, your Airstream motorhome can be safely parked in any spot that is relatively level and where the ground is firm. Your facilities are with you. You are self-contained. Try to pick as level a parking spot as possible.

Hydraulic Leveling Jacks

Some models are equipped with hydraulic leveling jacks that can be deployed. Complete instructions are included with the Owners Packet. Be sure to read the directions completely prior to operating the jacks. The jacks will be able to level your unit in most modern campgrounds. However, their capabilities are limited, and in some situations you will have to use planks to level the coach.

TV Backing Monitor (Option on 26")

The TV backing monitor can be extremely helpful, especially when traveling alone. The Owners Packet includes complete instructions on use. Practicing with the monitor in a safe place will make it much easier for you to use when it is really needed.

WINTER TRAVELING

Traveling in your motorhome during the cold winter months can be a most exhilarating experience. There are, of course, certain precautions that must be taken as you would in your home in low temperatures.



Warning: Always shut off the LP gas when gasoline is added to the fuel tank.

CAMPING

WINTER TRAVELING (Cont.)

Some states do not allow LPG to be turned on while moving. While traveling in these states you must use your common sense. How cold is it? How long will it be before you can turn the heat back on? Is the temperature dropping or rising? Remember, the wind chill factor when driving 50 MPH will cause the interior of the motorhome to cool much faster than when it is parked.

1. You must have a plentiful supply of propane gas.
2. If your stay is longer than overnight, you should endeavor to have 120-volt electricity available. The batteries, fully charged, will not last more than about 15 hours in freezing weather. Of course, you can run your generator to recharge the batteries, or even use the generator continually. Since the generator starts off the same battery as the engine, it is recommended to start the generator prior to shutting off the engine. This will prevent running the engine battery down should there be a difficulty in starting the generator in the cold temperatures.
3. Minimize use of electricity if 120-volt power source is not available.
4. Leave cabinet doors, bed doors and wardrobe doors slightly open at flight to allow circulation of air in and around all furniture components
5. Use propylene glycol type antifreeze in waste and drain water tanks to prevent freezing. Quantity of antifreeze needed will vary with ambient temperature and the amount of liquids in tank.
6. For extended stays in cold weather, insulate the water line outside the motorhome. You should remember that low temperatures in combination with high winds cause an equivalent chill temperature much below what your thermometer is reading. For instance, with an outside temperature of zero degrees, and the wind velocity of 10 miles per hour, the equivalent chill temperature is minus 20° F. The exterior water faucet has an in-line valve inside the motorhome. In below freezing temperatures, shut off the valve inside and open the exterior brass valve so it will drain. See the valve section in this book for locations.

CAMPING

EXTENDED STAY

Making a long trip is not very different from making a weekend excursion. Since everything you need is right at hand, you are at home wherever you go. When packing for an extended trip, take everything you need, but only what you need.

Some models are equipped with Hydraulic Leveling Jacks that can be deployed. Complete instructions are included with the Owners Packet. Be sure to read the directions completely prior to operating the jacks.

When you plan to stay in the same place for several days, weeks or months, you will want your motorhome to be as level as possible. Check the attitude with a small spirit level set on the inside work counter. If a correction is necessary, then you must first level from side to side. This can be done most easily by driving up a small ramp consisting of 2" x 6" boards tapered at both ends. **WE DO NOT RECOMMEND PLACING TIRES IN A HOLE FOR LEVELING.** Check the tire section of the chassis portion of this manual for information on tire support.

Hook Up to Water by attaching a ½ " minimum high-pressure water hose to the city water service, or the hose from the water reel if so equipped.

Plug the **Electrical Cable into the Power Service**. Be sure you have the wire grounded and have the proper polarity. See Electrical Section for technical details.

Cable TV/Telephone Hookup is located on the roadside rear corner of the motorhome. The television booster must be turned off for the cable system to operate properly.

To use the **Generator** you simply start it. All switching is done automatically. The generator can be started either from your interior monitor panel, dash switch or the switch on the generator itself.

It is easier on your generator and appliances if you'll allow the generator to reach its normal operating speed (about a minute) prior to applying heavy current loads.

Hook your **Waste Drain Hose into the Sewer Disposal Facility** and attach to the drain outlet in your motorhome. For details on this procedure see Drain and Waste System Section.

Turn on the gas supply and light the oven pilot. Lighting a top range burner to bleed any air from the system will make it easier to start other appliances.

When you stay for extended periods where electric or water hookups are not available, you must make regular checks on the condition of your 12-volt battery and the contents of your water tank. Carry drinking water in a clean bucket to refill your tank. When your waste tank nears capacity, move your motorhome to a dumping location.



WARNING: The escape windows(s) are identified by their red release handles. Pull red handle toward window center. Push out on the glass and it will swing clear. The window operation should be checked each trip and the latches lubricated with WD-40 or equivalent every six months. Do not parked in a manner that would prevent the escape windows from opening or block an emergency exit route.

CAMPING

EFFECTS OF PROLONGED OCCUPANCY

Your motorhome was designed primarily for recreational use and short-term occupancy. If you expect to occupy the motorhome for an extended period, be prepared to deal with condensation and the humid conditions that may be encountered. The relatively small volume and tight compact construction of modern recreation vehicles mean that the normal living activities of even a few occupants will lead to rapid moisture saturation of the air contained in the motorhome and the appearance of visible moisture, especially in cold weather.

Just as moisture collects on the outside of a glass of cold water during humid weather, moisture can condense on the inside surfaces of the motorhome during cold weather when relative humidity of the interior air is high. This condition is increased because the insulated walls of a recreation vehicle are much thinner than house walls. Estimates indicate that a family of four can vaporize up to three gallons of water daily through breathing, cooking, bathing, and washing. Unless the water vapor is carried outside by ventilation, or condensed by a dehumidifier, it will condense on the inside of the windows and walls as moisture, or in cold weather as frost or ice. It may also condense out of sight within the walls or the ceiling where it will manifest itself as warped or stained panels. Appearance of these conditions may indicate a serious condensation problem. When you recognize the signs of excessive moisture and condensation in the motorhome, action should be taken to minimize their effects. For tips on controlling condensation see the "Tips To Controlling Condensation" section.

Note: Your motorhome is not designed, nor intended, for permanent housing. Use of this product for long term or permanent occupancy may lead to premature deterioration of structure, interior finishes, fabrics, carpeting, and drapes. Damage or deterioration due to long-term occupancy may not be considered normal, and may under the terms of the warranty constitute misuse, abuse, or neglect, and may therefore reduce the warranty protection.

TIPS TO CONTROLLING CONDENSATION

To avoid condensation problems, try to follow these tips to help alleviate excess moisture.

Allow excess moisture to escape to the outside when bathing, washing dishes, hair drying, laundering, and using appliances and non-vented gas burners.

Always use the vent hood when cooking.

Keep the bathroom door closed and the vent or window open when bathing and for a period of time after you have finished.

Do not hang wet clothes in the motorhome to dry.

In hot weather, start the air conditioner early as it removes excess humidity from the air while lowering the temperature.

Keep the temperature as reasonably cool during cold weather as possible. The warmer the vehicle, the more cold exterior temperatures and warm interior temperatures will collide on wall surfaces, thus creating condensation.

Use a fan to keep air circulating inside the vehicle so condensation and mildew cannot form in dead air spaces. Allow air to circulate inside closets and cabinets (leave doors partially open). Please keep in mind that a closed cabinet full of stored goods prevents circulation and allows the exterior temperature to cause condensation.

CAMPING

TIPS TO CONTROLLING CONDENSATION (continued)

The natural tendency would be to close the vehicle tightly during cold weather. This will actually compound the problem. Simply put, you need to remove some of the warm air, and allow some cool outside air to get inside the vehicle, so the furnace will not recycle the humid interior air.

Use fluorescent ceiling lights and minimize prolonged use of incandescent lights, which produce heat and contribute to condensation in the roof above the ceiling lights.

ABOUT MOLDS

What are molds?

Molds are microscopic organisms that naturally occur in virtually every environment, indoors and out. Outdoors, mold growth is important in the decomposition of plants. Indoors, mold growth is unfavorable. Left unchecked, molds break down natural materials, such as wood products and fabrics. Knowing the potential risks is important for any type of homeowner to protect their investment.

What factors contribute to mold growth?

For mold growth to occur, temperatures, indoor or outdoors, must be between 40 degrees and 100 degrees Fahrenheit and also have a source of moisture, such as humidity, standing water, damp materials, etc. Indoors, the most rapid growth occurs with warm and humid conditions.

How can mold growth be inhibited?

By controlling relative humidity, the growth of mold and mildew can be inhibited. In warm climates, use of the air conditioner will reduce the relative humidity. Vents are located in the bathing and cooking areas and constant use is advised during food preparation and bathing, even during colder weather. Additionally, opening a window during these activities will assist in ventilation. In extremely humid conditions, the use of a dehumidifier can be helpful.*

Frequent use of your RV or cleaning regularly is an important preventive measure. Further, any spills should be wiped up quickly and dried as soon as possible. Avoid leaving damp items lying about. On safe surfaces, use mold or mildew killing cleaning products. Check sealants regularly, and reseal when necessary to avoid water leaks. Proper preventive maintenance to the RV and its accessories, as described both in this manual and in accompanying literature, will provide the best protection to the RV.

For more information of controlling moisture in the RV, please read, "Tips to Controlling Condensation," located in this manual.

*If using a dehumidifier, please read and follow all manufacturer instructions and recommendations to the use and cleaning of the dehumidifier.

CAMPING

SLIDE OUT OPERATION

The slide out room on the Land Yacht Low Profile models is designed for easy deployment.

A momentary switch located on the microwave cabinet operates the room. To extend or retract the room, push and release the switch. The room will slide into position and stop automatically. It is not necessary, and could be harmful to hold the switch down during room operation. To stop the room while it is in motion, push and release the switch. The room automatically reverses itself the next time the switch is pushed.

NOTE: Before a slide-out room can be deployed the ignition switch must be off. We also recommend leveling the coach prior to deploying the slide-out.

CAUTION:

1. Level and stabilize unit before operating slide out room. Failure to level unit may cause the room to operate improperly or cause damage.
2. Check for adequate clearance to outside and inside objects before extending or retracting room. Check that the driver's seat is forward enough to clear the room. Before retracting room look at the exterior awning/cover for the room and clear any debris that may have fallen onto it.
3. Read and follow all warning labels in the coach.



WARNING: To prevent accidental injury, stand clear of room while it is in motion. Check interior and exterior of motorhome for people that may be struck or pinned by the room. Never attempt to move the motorhome with the room extended.

The motor for the slide out mechanism has an emergency retraction/expansion feature. The motor is located under the lounge, bolted to the floor. It is accessible by removing the lounge's front panel. The end of the motor has a nut that can be turned with a wrench, or a socket and ratchet. The slide out mechanism manufacturer also provides a flexible socket extension that can be mounted to an electric drill chuck for easier operation of this emergency procedure. Turn the nut until the room is returned to its storage position.

EXTERIOR

The sidewalls and roof of your Airstream Land Yacht motorhome are laminated fiberglass with a gel coat exterior finish. No paint means the small mars and scratches can be polished out or repaired using gel coat. We recommend this be done professionally since excessive polishing can remove the gel coat.

There is no magic to caring for your motorhome. The finish is the same as non-painted fiberglass boats. As a general rule of thumb, we recommend the motorhome be washed about every four weeks and waxed in the spring and fall. To make sure your new unit is always protected, you should wax it immediately or have your dealer wax it just prior to delivery. In industrial areas cleaning and waxing should be done on a more frequent schedule.

Some areas may be fiberglass that is custom painted by Carrera Designs with an automotive finish. As a general rule of thumb, we recommend the motorhome be washed about every four weeks and waxed in the spring and fall also.

ALWAYS CLEAN YOUR MOTORHOME IN THE SHADE OR ON A CLOUDY DAY WHEN THE SKIN IS COOL. Oil, grease, dust and dirt may be removed by washing with any mild non-abrasive soap or detergent. Cleaning should be followed by a thorough clean water rinse. Spots and streaks may be prevented by drying the unit with a chamois or a soft cloth.

After cleaning and drying, a good grade of nonabrasive automotive paste or liquid wax will increase the life of the finish, especially in coastal areas where the finish is exposed to salt air, or in polluted industrial areas. It will also protect the shell from minor scratches and make subsequent cleaning easier.

It is important to remove sap, gum, resin, asphalt, etc., as soon as possible after they appear by washing and re-waxing. Sunlight and time will bake-harden these materials, making them almost impossible to remove without heavy buffing. If asphalt remains on the motorhome after washing, use a small amount of kerosene on a rag and wipe the spots individually, being careful not to scratch the finish.

It is recommended that the caulking and sealant used in external seams and joints such as window frames, light bezels, beltline and rub-rail molding, etc., be checked regularly. If this material has dried out and becomes cracked or checked, or if a portion has fallen out, it should be replaced with fresh material to prevent possible rain leaks. Caulking and sealing material is available from your motorhome dealer.

Main Door Lock

The door lock on your motorhome operates in the same manner as the locks used on most automobiles. Locking the latch actually disengages the linkage between the handles and the latch. This prevents forced entry by using large pliers on the lock handle.

We urge you to keep an extra set of keys for both the door lock and the ignition hidden somewhere on the exterior of the coach. We probably receive a dozen calls a year from people who have lost keys or locked them in the coach. Your keys will overcome the keyless lock system used on the dead bolt.

EXTERIOR

Occasionally you might find the latch catch, item 3 in the diagram below, out of time. This simply means it has been bumped and has flipped to the closed position when the door is still open. To re-time, hold the door handle in the open position, then pull out and down on the latch catch. It should flip to the open position as shown in the illustration.

LOCK ASSEMBLY, DRIVERS DOOR

1. Mounting plate, Door Lock
2. Lock Handle, Inside
3. Latch Catch
4. Keeper, Rod Linkage
5. "E" rings, Tumbler Installation

(Lock assembly as viewed from inside of door with cover plate removed.)

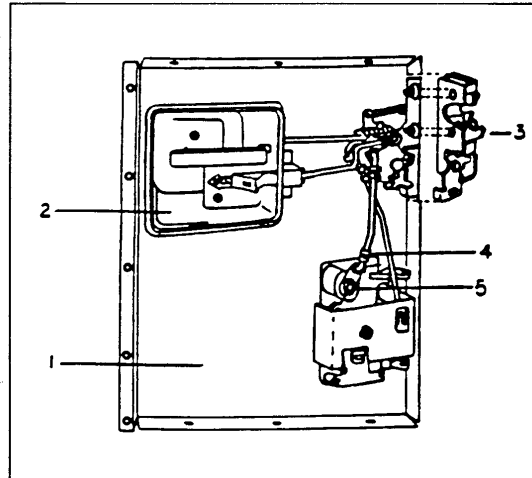

Access to the linkage mechanism of the lock is gained by removing the two screws holding the lock handle and the center panel of the inside door skin. This will expose the door lock assembly, as shown in the illustration.

The tumbler is replaced by removing the inside lock handle and the center panel of the inside door skin so the lock assembly is exposed. Insert key into tumbler then remove the "E" ring (item #5 on Illus), being careful it is not lost.

LOCK ASSEMBLY, MAIN DOOR

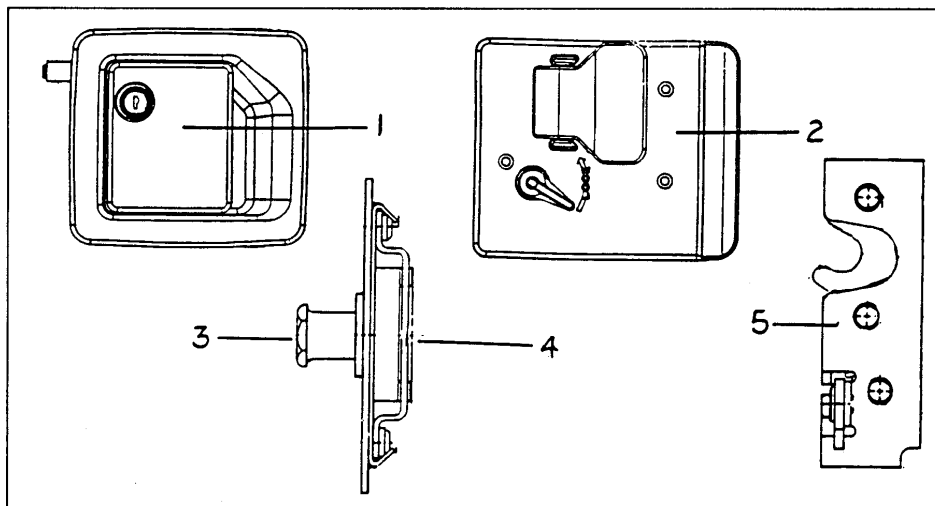

1. Outside housing assembly
2. Inside plate
3. Striker bolt
4. Caged nut
5. Rotary latch

EXTERIOR

KEYLESS DOOR LOCK

Operation

The dead bolt portion of your motorhome may be controlled by radio signals produced by the key fob shown below. One characteristic of this system is the one second delay after a pad has been depressed.

NOTE: When you use the keypad to turn the patio lights ON you must also use the keypad to turn them OFF. The same goes for the switch inside the door ... if you turn the lights on with this switch, you must use the same switch to turn them off. You cannot turn the lights on with the keypad and off with the switch.

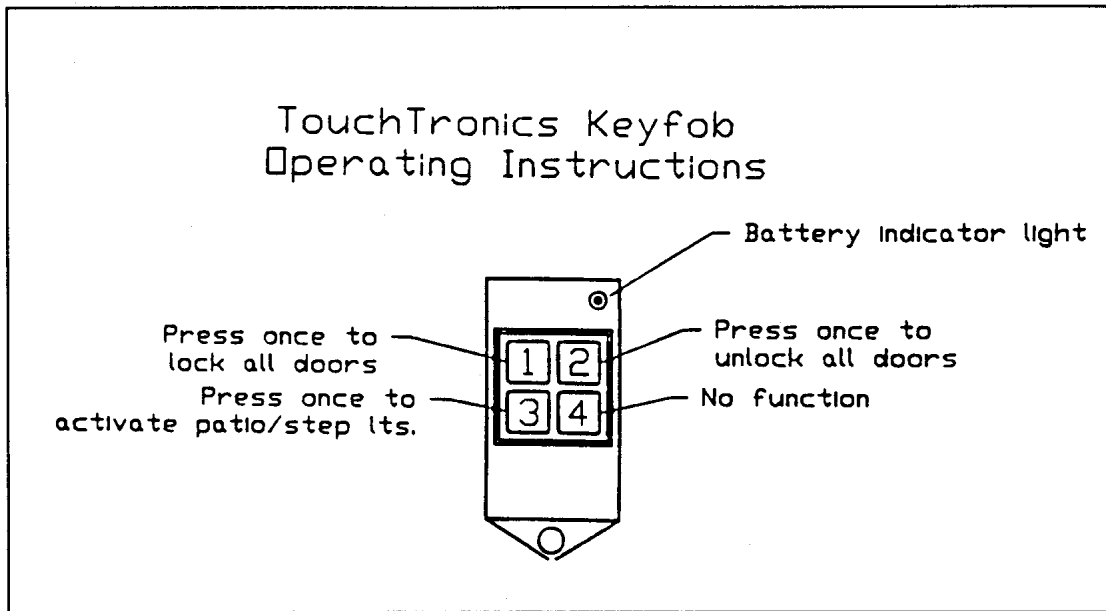

SERVICE

There are four major components operating the door locks; control module/receiver, dash switch, relay, and drive motors. The control module is mounted on the inside wall just behind the main door. The relay operates in conjunction with the dash switch and is located up under the left hand side of the dash. The drive motors, located at each lock, are polarity sensitive. When testing you'll find the wires at the drive motors will switch from positive to negative and vice versus as the key fob or dash switch is being operated. When using the dash switch the relay under the dash performs the polarity switching functions and the control module/receiver serves the same function when the key fob is used.

A detailed wire layout is provided in the electrical section of this manual.

EXTERIOR

ROOF LADDER

Lifting up on the bottom section of the ladder will release the hinge and allow the ladder to be pivoted down to use position. The ladder has two pins that inserted snugly into the nylon sockets.

To store, pop the ladder bottom out of the nylon sockets and fold the ladder upward at its hinge, as it nears vertical, the slot in the hinge will fall into a locked position and hold the ladder up. If the ladder is down and rear compartment access is required, the bottom of the ladder is pulled out of the sockets (a good hard tug is needed) then swung up vertically. For traveling, the ladder bottom should be in the up position and locked securely. The hinge is self-locking in the up position, however a slight tug is always a good check.



Warning: The intent of the ladder is for service access to roof mounted components by trained service technicians. Vertical ladders require physical dexterity and safe conditions to climb. The ladder and roof can be a dangerous place, especially when wet, or in snow and ice. Falls from the roof or ladder with serious or fatal injuries are possible. Only you can judge your physical abilities and the environment for safety as you contemplate using the ladder. If in doubt, be safe, and please stay off the ladder and the roof!

CAUTION: The maximum roof capacity is 250 lbs. spread over a minimum of 4'x 4' area. This criteria is easily met by the service technician placing appropriately sized paneling or plywood on the roof.

POWER AWNING (OPTION)

Just inside the main door is a switch used to extend and retract the optional power awning. An exterior switch is located in the lower exterior compartment behind the main door. Please read and follow all operational guidelines as set forth in the awnings owner manual that is inserted in the Silver Key Book before operating the power awning.

INTERIOR

The luxurious interior of your Airstream motorhome has been designed for comfort, convenience, durability and appearance. An understanding of the operational procedures and maintenance techniques of the interior appointments will add to your pleasures, as well as to the long life of your motorhome.

Lounges

To convert the Deluxe Sofa into a bed, pull straight up and remove armrest, grasp the front edge of the seat, raise and pull it toward the aisle of the motorhome. The backrest will slide down into place automatically.

Swivel Chairs

The chairs have two adjustments. One lever will allow the chair to rotate. The other lever lets the chair slide forward and back.

CAUTION: Rotating the chair when it's slid back against the wall can damage the upholstery. Position the chair so it isn't chafing when in transit.

CAUTION: Never remove cushion cover for separate cleaning or washing. Any tumble cleaning method can destroy the backing, shrink or otherwise damage upholstery.

Shades

The main door shade is operated in the same manner as most Venetian blinds. Pulling down on the tab lowers the shade and it will catch on its own. A slight pull downward will release the shade and it can slowly be returned to the open position.

Day-Night shades are lowered and raised by the bars running across the shade. Grasp in the center of the bottom bar or place hands evenly on the bar. Pull the bottom bar down to the lower sill. A center bar with small handles can be lowered (night) or raised (day). Rough roads and long trips may cause the pleated shades to come down slightly during travel. Tensions on the strings at the sides of the shades adjust the ease of operation and their ability to stay up during travel. Do not over-tighten as this may cause the string to break, requiring service.

A feather duster, or the soft-bristled brush often found as part of vacuum cleaner attachments, are recommended for cleaning the blinds and pleated shades. The longevity of the pleated shades will be increased if the shades are in the up position when your vehicle is stored.

Carpet

The carpet can be cleaned with any good commercial carpet cleaner, or with a detergent and water. **HOWEVER, BE CAREFUL NOT TO SOAK THE CARPET WITH WATER.**

INTERIOR

Hardwood Flooring

Daily care for the planked hardwood floor is by vacuuming. Occasionally waxing with a non-water base wax will help extend the life of the floor.

CAUTION: Warn occupants of the vehicle when fresh wax has been applied, just like a home, the floor will be slippery.

Vinyl Floor

The vinyl floor in your unit can be cleaned with liquid floor cleaning solutions recommended for vinyl floors and warm water.

Counter areas

The counter areas around the sink are of a high-pressure laminate or Corian and can be cleaned with soap and water, or you can use a common solvent on tough spots. Be sure no abrasive cleaner is used, as there is the possibility it could scratch the surface. A protective pad should always be placed under hot utensils.

Sanding minor damaged areas can repair Corian counters. The color of the material is constant and not just a surface coat.

Wall/Cabinets

The vinyl walls of the motorhome can be wiped with any mild household cleaner. The wood grain panel also has a vinyl covering for easy care. The cabinet doors and framework are hardwood, so any good furniture polish can be used.

CAUTION: Do not use any abrasive material on the vinyl-covered walls.

Bathroom

The counter areas around the lavatory sink are of a high-pressure laminate or Corian and can be cleaned with soap and water, or you can use a common solvent on tough spots. Be sure no abrasive cleaner is used, as there is the possibility it could scratch the surface.

Sanding minor damaged areas can repair Corian counters. The color of the material is constant and not just a surface coat.

Shower Stall

To clean your ULTRA/GLAS shower stall unit, use warm water and one of the stronger liquid detergents. Do not use abrasive cleaners; they may scratch and dull the surface of your ULTRA/GLAS unit. Stubborn stains can be removed with solvents such as turpentine, paint thinner or acetone. Restore dulled areas by rubbing with an automotive-type liquid cleaner, and then put the soft glow back into your ULTRA/GLAS unit with a light application of liquid wax.

INTERIOR

Fabric Cleaning



Warning: Keep your furniture and family safe from fires caused by careless smoking. Do not smoke when drowsy. Remove immediately any flowing ash or a lighted cigarette that falls on furniture. Smoldering smoking material can cause upholstered furniture fires.

All material should be professionally dry cleaned to remove any overall soiled condition. These materials may be spot cleaned, however, using the cleanability code instructions as listed, Sample swatches are furnished to our dealers. The dealer will be able to give you the cleaning code and part number for the fabrics used in your particular motorhome.

The following are the cleanability code instructions for the various fabrics used in the Airstream motorhomes:

Cleanability Codes

CODE W-S

Fabric care. Spot clean this fabric either with a mild solvent or a water-based cleaning agent. When using a solvent or dry cleaning product, follow instructions carefully and clean only in a well-ventilated room. Avoid any product that contains highly toxic carbon tetrachloride. You may also use an upholstery shampoo product or the foam from a mild detergent. With either method, pretest a small area before proceeding. Use professional furniture cleaner when an overall soiled condition is reached.

CODE S

Fabric care. Spot clean, using a mild, water-free solvent or dry-cleaning product. Carefully follow instructions on such product. Clean only in a well-ventilated room. Avoid any product containing carbon tetrachloride, which is highly toxic. Pretest small area before proceeding. Use professional furniture cleaner when an overall soiled condition is reached.

CODE W

Fabric care. Spot clean, using the foam only from a water-based cleaning agent, such as mild detergent or non-solvent upholstery shampoo product. Apply foam with a soft brush in a circular motion. Vacuum the area its when dry. Pretest small area before proceeding. Use professional furniture cleaner when an overall soiled condition is reached. The manufacturer of the fabric designed the above code.

INTERIOR

Drapes

Use the following procedures to remove drapery panels for cleaning

Front Wrap Around Drapes

1. Remove screws securing rear end of drapery track bracket to wall, both roadside and curbside.
2. Remove the plastic end cap.
3. Slide draperies to the rear until they are clear of track.
4. After reinstalling drapes, replace the caps and refasten the track.

CAUTION: All drapery materials and mattress covers must be professionally dry-cleaned.

To prevent excessive wear to drapery linings, blinds must be secured at the bottom and slats turned vertically when driving long distances.

Bench Dinette

The dinette is hinged to the wall and is supported by one folding table leg. To make into a bed, the front of the table is lifted slightly and the leg is then folded up against the bottom of the tabletop. The pressurized piston will hold it into place. Raising the front of the table leaf further allows it to be unhooked from the wall. The leaf will then swing out and down onto the support ledges on the front of the dinette seat. The backrests are then laid on the table leaf to complete the bed. On units with a freestanding dinette, be sure to secure the dinette chairs to the dinette table support using the fabric straps.

CAUTION: Never remove cushion cover for separate cleaning or washing. Any tumble cleaning method can destroy the backing, shrink or otherwise damage upholstery.

Free Standing Dinette

Your unit may be equipped with a freestanding dinette. The dinette tabletop pulls away from the wall on a slide and a leaf is provided to extend the top. Hold on to the end of the table and give it a slight tug to release the top from its wall catches. Once free from its catches, the table can be extended into its full length. The chairs have straps to stabilize them during travel.

PLUMBING

LPG SYSTEM

Your motorhome is equipped with a permanently mounted tank for LPG (Liquid Petroleum Gas). LPG burns with a clean blue flame. There are two basic types of LPG in common usage: Butane and Propane. Butane is widely used where temperatures are normally above freezing the year round, and Propane is used where subfreezing temperatures are common, since Butane freezes at 32°F as compared to -40°F for Propane. ALL OF THE ORIFICES IN THE LPG APPLIANCES ARE OF THE UNIVERSAL TYPE THAT WILL BURN EITHER FUEL. How long a full tank of gas will last is dependent on usage. In cold weather, when you are using the furnace, large amounts of hot water, and cooking extensively, you will naturally use more than you will in warm weather, when you may do limited cooking. On the average, with normal cooking and other appliance use, you can probably count on one month of usage from the tank.

If you have allowed the tank to run out, air may have gotten into the lines. In this event the air must be forced out through the lines by gas pressure before you can light the pilots. Hold a match to the pilot of the appliance closest to the tanks until it lights and stays lit. Then move to the next closest, etc.



Warning: All pilot lights and appliances must be turned off during refueling of motorhome fuel tank and permanently mounted LPG tank. Gas lines should be checked periodically for leaks with ammonia free soapy water. Do not use open flame.



Warning: If gas can be smelled, appliance pilots fail to stay on, or any other abnormal situation occurs, shut off tank valve immediately and call on a qualified LPG service center or Airstream Service Center.

CAUTION: Moisture in the LPG tank will cause a malfunction of the regulator in controlling proper pressure. This may result in the flame lifting off the burner, or the flame may go out frequently. Many refueling stations will add approximately ¼ to ½ gallon of alcohol to lower the moisture temperature. Moisture will then pass through the regulator without the formation of ice crystals.

LPG Regulator

The LPG regulators used on Airstream motorhomes are designed for low-pressure service, with a normal outlet pressure setting of 11.5 inches water column. Only personnel trained in the proper procedures, codes, standards, etc., should service regulators.

Have the regulator inspected each time the tank is refilled. Make sure the regulator vent opening on both first and second stage regulators does not become plugged by mud, insects, snow, ice, paint, etc. Vents must remain open.

Replace any regulator that has had water in the spring case, or shows evidence of external corrosion, or corrosion inside the spring case. Closely examine regulators directly connected to the container valve by means of a solid POL adapter (horizontal mounting) for signs of corrosion. (An Airstream Service Center is recommended for this service.)

PLUMBING

BASIC RULES FOR SAFETY



Warning: DO NOT store LP containers within vehicle. LP containers are equipped with safety devices that vent gas should the pressure become excessive.



Warning: DO NOT use cooking appliances for comfort heating. Cooking appliances need fresh air for safe operation. Before operation open overhead vent or turn on exhaust fan and open window.

A warning label has been located in the cooking area to remind you to provide an adequate supply of fresh air for combustion. Unlike homes, the amount of oxygen supply is limited due to the size of the recreational vehicle, and proper ventilation when using the cooking appliances will avoid dangers of asphyxiation. It is especially important that cooking appliances not be used for comfort heating as the danger of asphyxiation is greater when the appliance is used for long periods of time.



Warning: Portable fuel burning equipment, including wood and charcoal grills and stoves, shall not be used inside the recreational vehicle. The use of this equipment inside the recreational vehicle may cause fires or asphyxiation.



Warning: A Warning Label has been located near the LP gas container. This label reads: DO NOT FILL CONTAINER (S) TO MORE THAN 80% PERCENT OF CAPACITY. Overfilling the LP gas container can result in uncontrolled gas flow that can cause fire or explosion. A properly filled container will contain approximately 80 percent of its volume as liquid LP gas.



Warning: Do not bring or store LP gas containers, gasoline or other flammable liquids inside the vehicle because a fire or explosion may result.



Warning: If you smell gas:

1. Extinguish any open flames, pilot lights and all smoking materials.
2. Do not touch electrical switches.
3. Shut off the gas supply at the tank valve(s) or gas supply connection.
4. Open doors and other ventilating openings.
5. Leave the area until odor clears.
6. Have the gas system checked and leakage source corrected before using again.





Warning: LP gas regulators must always be installed with the diaphragm vent facing downward. Regulators that are not in compartments have been equipped with a protective cover. Make sure that regulator vent faces downward and that cover is kept in place to minimize vent blockage that could result in excessive gas pressure causing fire or explosion.

PLUMBING

LP TANK

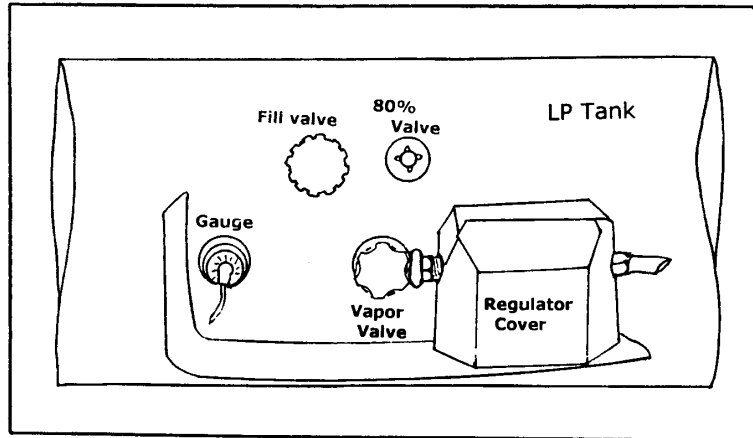
The regulator at the L.P. tank is under a black plastic cover. The protective cover certainly helps to keep the vent on the regulator from getting clogged by wasps or ice, but should still be checked regularly to make sure the vent remains clear.



 **WARNING:** Do not attempt to seal regulator cover.

 **WARNING:** Check vent each time tank is filled to make sure it is clear of obstructions.

PLUMBING

WATER SYSTEM - SELF-CONTAINED

The fresh water system consists of a water fill, fresh water tank, water-pump, pump filter, hot and cold water lines, water heater, drain valves, and faucets.

To operate the system:

Turn the water heater by-pass valves to normal flow position.

The by-pass valves are located under the lavatory cabinet in the 33' model (accessed by removing the lower shelf vertical close-out), under the wardrobe in the 30' model (pull off the small raised panel door held on by pressure latches below the wardrobe door) and under the bedroom wardrobe in the 26' (open the lower door). For normal operation open valves A and C and close valve B. (Reverse the valves and drain the water heater for winterization).

Check all drain valves and turn them to the closed position as needed.

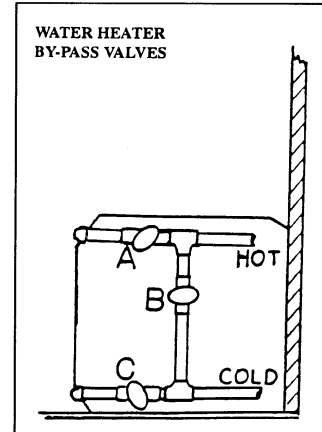

Fill the water tank by opening the exterior door marked water fill, remove screw cap and pull the vent plug. A garden hose can now be inserted. It's a good idea to let the water run through the hose for a short time to flush it out. RVers sometimes fill their tanks with "home" water to avoid strange water that may be distasteful to them on short outings. Remember the more water you carry in the fresh water tank, the less cargo carrying capacity you have for other items.

The amount of water in the tank may be checked on the Monitor Panel, or you may fill the tank until water overflows out of the fill.

Open the hot side of the galley or lavatory faucet and fill the water heater by turning on the water pump switch located on the monitor panel or connecting to an exterior city water source. For some time the open faucet will only sputter. This is because the water heater is being filled and air is being pushed out through the lines. Once the water heater is full, a steady stream of water will come from the faucet. Now open a cold faucet. It will sputter for a short time, but will soon expel a steady stream. All other faucets can now be opened until all air is expelled.

Once the system is filled with water and the faucets are closed, the water pump will shut off. To prevent equipment damage the water heater should only be started after the water system is primed and ready for use.

When a faucet is opened the pump will come back on automatically. If the faucet is just barely open it is normal for the pump to cycle on and off rapidly.

It is normal for a pump to occasionally cycle when all faucets are off to keep the water pressure at the set point, however, if it cycles frequently (more than a few times an hour) the plumbing system and pump should be checked to be sure it is not losing pressure through a slow water leak or back through the pump.

Note: Water pressure at some campgrounds may be low. The water pump can be turned on to assist the city water pressure. Be sure there is water in the fresh water tank. The pump will only use the water that is needed out of the tank to bring the pressure up to the usual standard.

Caution: Turn the water pump off when the motorhome is left unattended.

PLUMBING

WATER PUMP AND STRAINER

The water pump and strainer are located under the rear bed and can be accessed by opening the door at the bed footboard. The strainer should be visually checked for accumulation of sand or debris that could affect water flow.

To clean the strainer screen, first remove the inlet connection from the pump side of strainer. This will allow the intake side of the strainer to be rotated about 1/8 turn counter clockwise and be removed. The screen part of the strainer will now be accessible for cleaning.

When reassembling only rotate the inlet side of the strainer until the stops are felt. The "O" ring performs the sealing and too much pressure will only break the strainer.

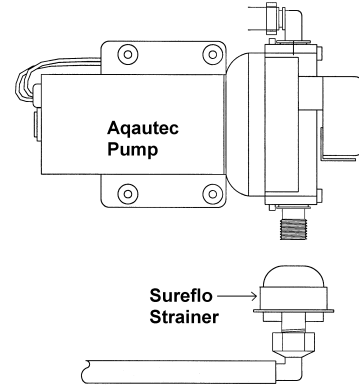

SANITIZING

Potable water systems require periodic maintenance to deliver a consistent flow of fresh water. Depending on use and the environment the system is subject to, sanitizing is recommended prior to storing and before using the water system after a period of storage. Systems with new components, or ones that have been subjected to contamination, should also be disinfected as follows:

1. Use one of the following methods to determine the amount of common household bleach needed to sanitize the tank.
 - A) Multiply "gallons of tank capacity" by 0.13; the result is the ounces of bleach needed to sanitize the tank.
 - B) Multiply "Liters of tank capacity" by 1.0; the result is the milliliters of bleach needed to sanitize the tank.
2. Mix into solution the proper amount of bleach within a container of water.
3. Pour the solution (water/bleach) into the tank and fill the tank with potable water.
4. Open all faucets (Hot & Cold) allowing the water to run until the distinct odor of chlorine is detected.
5. The standard solution must have four (4) hours of contact time to disinfect completely. Doubling the solution concentration will allow for contact time of one (1) hour.
6. When the contact time is completed, drain the tank. Refill with potable water and purge the plumbing of all sanitizing solution.

NOTE: The sanitizing procedure outlined above is in conformance with the approved procedures of RVIA ANSI A 119.2 and the U.S. Public Health Service.

PLUMBING

WATER PUMP

Manufacturer:

Aquatec
17422 Pullman Street
Irvine, CA 92614
Phone: 800-975-9995
Phone: 949-225-2200
Fax: 949-225-2222
Web site: www.aquatec.com

Aquajet RV Series.

This revolutionary pump employs state-of-the-art electronics to automatically control motor speed -the pump actually adjusts its speed as you open and close water fixtures. The Aquajet RVs exclusive soft start feature eliminates annoying rapid cycling, and its exclusive 5-valve design can deliver twice the flow and pressure conventional RV industry pumps.

OPERATIONAL GUIDELINES AQUAJET RV PUMP

(Partial Reprint. Please contact Aquatec for complete instructions.)

Please read these Operational and Installation Guidelines before installing or operating the AQUAJET RV PUMP. If additional help is needed, please consult the Factory.

CAUTIONS:

- A. The pump is equipped with an electrical speed controller; please insure that electrical connections are made in accordance with these instructions.
- B. The pump is equipped with a pressure sensing demand switch, which controls the maximum operating pressure as set at the Factory. Never subject the pump to pressures above 125 PST (9.5 bars).
- C. Never operate the pump in a harsh environment or hazardous atmosphere, since motor brush and switch may cause electrical arcing.
- D. Pump head materials are designed for use with water only. Do not use with petroleum products.
- E. As long as there is inlet water pressure, the pump will not stop forward flow of water even if the motor is turned off. Be sure the system has a positive means of shutting off water supply.
- F. Always consider electrical shock hazards when working with and handling electrical equipment. If uncertain, consult an Electrician. Electrical wiring should be done by a qualified electrician only, and all local and State Electrical Codes must be followed.

Do not subject the pump to extreme high or low (freezing) temperatures while in operation. (Operating ambient temperature range is 32° to 115° F).

The pump will only prime if all pressure is relieved from the outlet port

PLUMBING

CITY WATER HOOKUP

Use a high-pressure hose of at least ½ " diameter. It should be one that is tasteless, odorless and non- toxic designed for RV use. The city water inlet is a standard garden hose thread. We suggest you carry two lengths of hose.

This way you have the ability to reach hookups further away than normal, plus you have a spare hose should one fail or become damaged unexpectedly. Turn the water heater bypass to the normal flow position as described under self- contained.

After hooking up the hose and turning on the city water valve provided in the park, slowly open a faucet. There will be a lot of spurts and sputtering until all the air is expelled from the motorhome system. If the water heater is empty it will take some time before all the air is expelled and you get a steady flow of water at the faucet. Once a steady flow is achieved at one faucet, the others should be opened long enough to expel the air in the lines going to them.

Water pressure at some campgrounds may be low. *The water pump can be turned on to assist the city water pressure.* Be sure there is water in the fresh water tank. It is not necessary to fill the tank, the pump will only use the water that is needed out of the tank to bring the pressure up to the usual standard. The water pump should be turned off when the motorhome is left unattended.

Your plumbing system has a built in pressure regulator to protect your lines and faucets from extremely high pressures on some city water systems. An after-market external regulator could lower the water pressure at the inlet and thus to your faucets and shower.

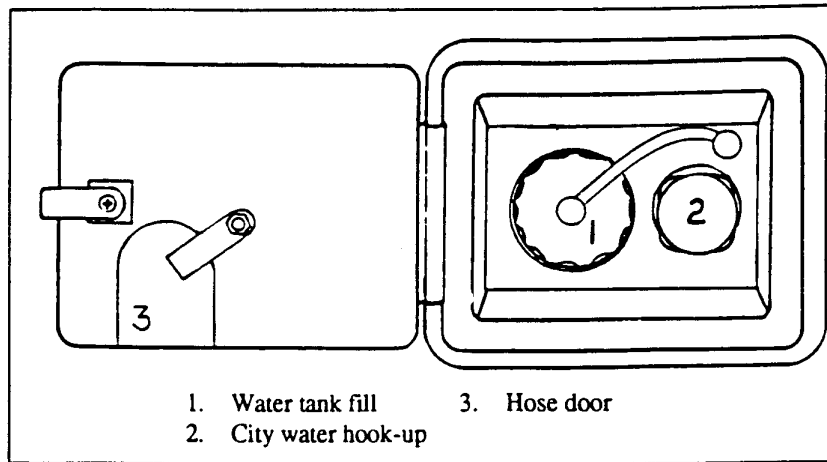

PLUMBING

EXTERIOR WATER SERVICE

On the side of the 26' and 30' motorhomes is a large utility compartment with a keyed door. A spigot and garden hose female connector is inside. On the 33' model in the roadside rear utility compartment on the left rear lower side is a water hose connector marked "black tank flush" and the exterior water spigot.

The spigot is plumbed into the fresh water system of the motorhome. This is an ideal place to rinse the sand off your feet after going to the beach, cleaning mud off your boots and hundreds of other messy jobs that are better done outside of your motorhome.

GALLEY FAUCET-MOEN PURETOUCH CLASSIC

WATER FILTRATION SAFEGUARDS

Your Moen PureTouch® Classic Filtering Faucet System integrates carbon block filtration technology designed by Culligan International into a faucet spout. This technology is fast and effective at reducing contaminants commonly found in water and is certified by NSF® International. The PureTouch Filtering Faucet System and installation must comply with State and Local laws and regulations. To ensure optimal operation of your new Moen faucet, please read the following safeguards carefully.

MicroTech™ Filter Cartridges

- MicroTech filter cartridges will reduce:
 - Chlorine, Taste and Odor (MicroTech 400, 600)
 - Lead (MicroTech 400,600)
 - Cysts (Cryptosporidium, Giardia) (MicroTech 600)*
- *The contaminants removed or reduced by this filter are not necessarily in your water.
- Do not use with water that is microbiologically unsafe or of unknown quality without adequate disinfections before or after the system. Systems certified for cyst reduction may be used on disinfected waters that may contain filterable cysts.
- MicroTech filter cartridges are designed for replacement after dispensing 200 gallons of filtered water. Water conditions and usage may affect filter life and water taste.
- The electronic indicator will signal when filter replacement is necessary
- Use only MicroTech 400 or 600 filter cartridges with the PureTouch *Classic* Filtering Faucet System.
- Filter flow rate = .4-.5 gpm at rated pressure (20 psi min. – 125 psi max.).

Water Temperature

- Minimum/Maximum faucet operating temperature = 40 degrees – 150 degrees F
- **CAUTION: Do not filter water above 100degrees F.**

MicroTech Filter Flushing Instructions

- New MicroTech Filter Cartridge: Allow cold water to run through a new filter for 5 minutes to flush out any loose carbon particles. Once these small black specks are washed out the filter is ready for use.
- Daily Use: Allow cold water to run through the filter for 10-15 seconds prior to first use. If the filter has not been used for two days, run cold water through the filter for 60 seconds prior to use.

Questions If you have any questions please call Moen's toll-free help lines:

1-877-DRINK-H2O Monday through Friday 8:00 a.m. to 8:00 P.M.

1-877-374-6542 Saturday 8:00 a.m. to 6:30 p.m.

**MICROTECH™ FILTER
INSTALLATION/REPLACEMENT**

1. Install a new filter by wetting the outlet ports with water and then inserting into the round filter ports on the faucet head and pushing the filter and head together. Both outlet ports must be fully inserted into the filter ports.
2. Install the filter and faucet head assembly on to the spout by wetting the faucet head o-ring seal and then carefully sliding the free end of the filter into the spout. The head will need to be initially turned approximately ½ turn counter clockwise from its normal position to slip past the safety catch. Lock the head into place by simultaneously pushing and twisting the head clockwise. When properly installed the head will feel secure, and will be correctly oriented on the spout.
3. Reset the filter life indicator by pushing the filter button 3 times. Wait 10 seconds. You should not be running water while resetting the filter life indicator because the filter button will remain depressed, with the first push as it switches to filter mode. The filter life indicator has been correctly reset if a short series of rapidly flashing green light occurs, indicating that the new filter-flushing period has begun.
4. Flush the filter for 5 minutes before initial use.

Your new Moen faucet is now ready for normal use.

To replace filter:

1. Turn off the faucet. Remove the faucet head by twisting it approximately ¼ turn counter clockwise to unlock it. Gently pull the faucet head away from the spout and twist it approximately another ¼ turn to get the faucet head past the safety catch. The faucet head and depleted filter (if one is installed) can now be pulled completely out of the spout.
2. The filter is held to the faucet head by two outlet ports, which connect into the head. Remove the old filter by simply pulling it straight off. Discard the old filter and install a new MicroTech 400 or 600 filter.

Note: The faucet will function correctly in unfiltered stream mode with or without a filter installed. The faucet will not function correctly in filter mode without a filter. If a filter is not installed and the filter button is depressed, unfiltered water will flow from both the filtered water outlet and the stream outlet aerator, and the filter button will not automatically stay depressed.

Use only Microtech 400 or 600 filter cartridges with the PureTouch Classic Filtering Faucet system. The Microtech filters are high performance carbon block filters developed specifically for the PureTouch system.

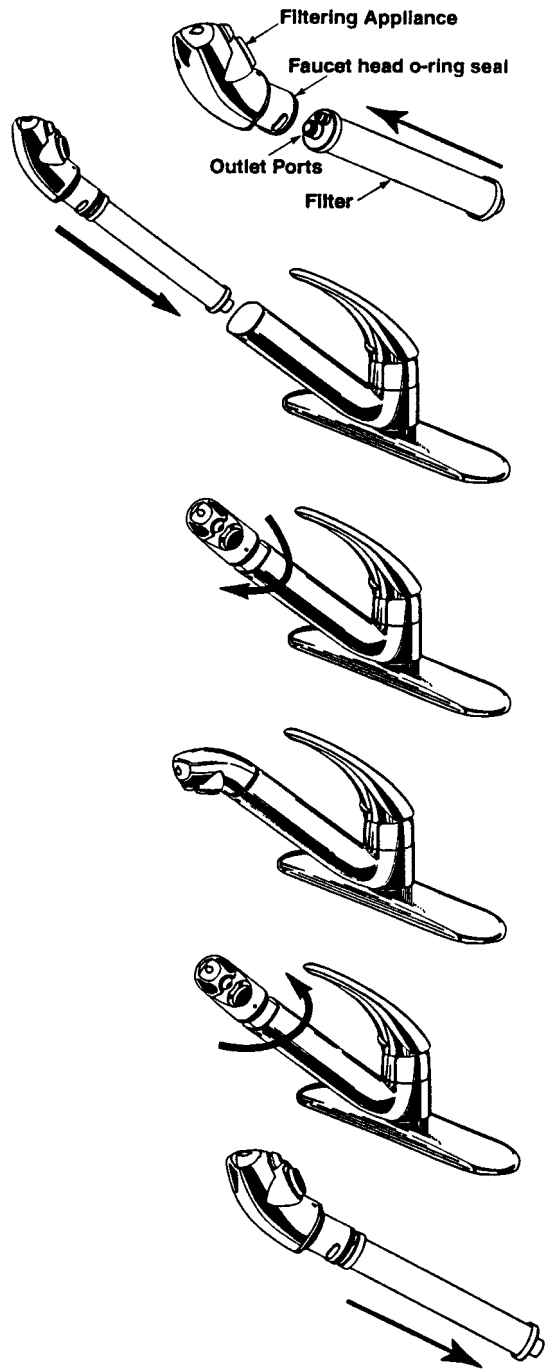

PLUMBING

OPERATING INSTRUCTIONS

Controlling The Water

The PureTouch system has two options for water delivery, unfiltered stream and filtered water.

STREAM MODE: Unfiltered water in regular stream flow

When the water is turned on at the faucet, the spout will always begin operating in the regular stream mode.

FILTERED WATER MODE: Filtered water dispensed through the separate filtered water outlet.

Pressing the front filtered water button will divert water through the filter and dispense filtered water from a separate outlet. To exit the filter mode, shut off the faucet.

CAUTION: Only filter cold water. Do not filter water above 100 degrees F.

Electronic Indicator

The flashing light on the electronic filter life indicator provides information regarding the performance of the filter. The indicator provides you with information throughout the life of the filter to help communicate the level at which it is performing.

Indicate Color	Performance
Amber & Green	A new filter must be flushed with cold water for 5 minutes after it is installed. This procedure helps clean the filter of loose carbon particles.
Green	Filter performing at optimum efficiency.
Amber	Warning: Filter is ready for replacement. (Approximately 16 gallons left.)
Red	Warning: Filter life is deleted, discard old filter and replace with a new Microtech 400 or 600 filter.

*If fast red doesn't change to slow amber/green after memory has been reset, reset was not complete and needs to be redone. Follow step 3 on the previous page.

A standard replaceable 3V lithium watch battery (2032) designed to last several years powers the electronic indicator.

Battery Replacement

Follow filter replacement instructions to remove filter appliance. Locate battery compartment drawer, pull out and replace battery, positive side up.

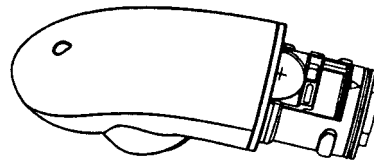

CARE AND MAINTENANCE

All that is needed to clean your faucet is a soft damp cloth. Moen does not recommend the use of scour pads, cleansers or chemicals. The abrasive nature of these substances could damage the faucet's finish. A non-abrasive car wax will help to protect the finish. DO NOT SUBMERGE OR PLACE FAUCET HEAD IN DISHWASHER.

PLUMBING

Moen Two Handle Lavatory Faucet

Moen Model 4720

USA

Moen Inc.
25300 AL Moen Dr
North Olmstead, OH. 44070-8022
1-800-Buy-Moen (289-6636)

Canada

Moen Inc.
2816, Route Bristol, Oakville
Ontario, L6H5S7
1-800-465-6130, Toronto: 905- 829-3400

Care Instructions for the Non-Tarnish Finish

As with any fine polished surface, your faucet will retain its shine for years to come with proper care. The LifeShine™ finish on this faucet does not require the extraordinary work needed to maintain most fine polished brass finishes.

Be sure to read and follow usage instructions enclosed with any scour pad or scrub sponge before use.

- **Caution:** Do not use pads or sponges that specifically do not recommend use for cleaning polished surfaces.
- **Caution:** Many pads or sponges with green fibrous surface (such as Scotch-Brite™ heavy duty scrub sponges) contain microscopic mineral particles that can scratch nearly all polished surfaces, including this faucet finish.

The LifeShine™ finish can be cleaned with most household cleaners (including mild abrasives), when used according to their manufacturers instructions for use.

- Rinse any strong cleaners off immediately after use to maintain the LifeShine™ finish luster. Mild scrubbing with fine steel wool (0000 grade) can remove built up dirt or water stains.

Visible water spots on this highly lustrous and reflective finish can be easily wiped off with a cloth dampened with water or with glass cleaner.

Moen Cartridge Removal

CAUTION: Always turn water OFF before removing or disassembling the valve. Open valve handles to relieve water pressure to insure that complete water shut-off has been achieved.

1. Holding the handle (2) or (18) with one hand, unscrew the handle hub (9) counterclockwise and set aside.

2. Unscrew the cartridge nut (11) counterclockwise.

3. Grasp the cartridge stem with pliers being careful not to damage stem and pull straight up.

4. To reassemble, reverse the previous steps. Turn the cartridge stem to ON position, so that the hole in the piston lines up with the hole in the outer shell. Push the cartridge straight down into the body making sure the key on the cartridge fits into the notch in the body. This will correctly position the cartridge. Replace the cartridge nut, start by hand, **DO NOT CROSS THREAD**, and tighten firmly.

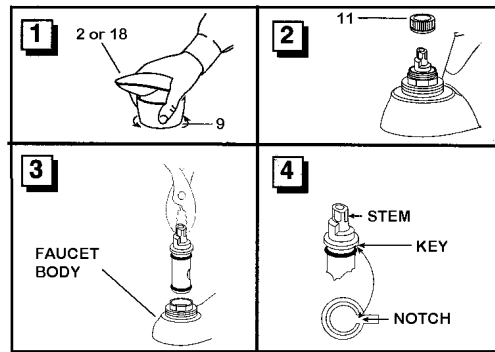

In the US call Moen's toll free Help line number, 1-800-Buy-Moen (289-6636) for answers to any product, warranty, or installation questions.

In Canada call 1-800-465-6130, Toronto: 905- 829-3400.

PLUMBING

DRAIN AND HIGH PRESSURE WATER VALVES

Your Land Yacht motorhome has several water line, tank drain, and shut off valves.

Drain Valves

On the 30' and 33' models 3 valves are located under the double bed behind the hinged door. If you have a twin bed model, these 3 valves would be located under the curbside twin bed behind the lower access door at the front edge of the bed base. The 26' model has 3 valves located in the roadside rear lower compartment. One each for draining hot and cold water lines and the third drains the water tank.

1 drain valve or plug on all models is located on the water heater exterior and is accessible through the water heater access door.

Hot Water heater Bypass

3 more valves are for the water heater by-pass system.

Access - 26 foot -30-foot - pull off panel below wardrobe.
 33 foot - open lavatory cabinet and pull out vertical panel.

1 valve is the brass exterior service valve:

Access- 26 foot, 30 foot – On the side of the coach inside Exterior Water Service
 compartment
 33 foot - Roadside rear utility compartment.

Shut Off Valves

1 shut off valve will be inside the coach on the exterior water service line. During cold weather usage you'll want to close the valve and open the brass exterior valve to drain the water so it won't freeze and burst.

Access - 26 foot - under rear roadside dinette seat.
 30 foot - under lavatory, just above shelf vertical backer.
 33 foot - open lavatory cabinet and pull out vertical panel.

1 shut off valve will be at the base of the toilet to shut off the water supply to the toilet for service or winterizing.

1 shut off valve is for the optional icemaker.

Access - 26' & 30' – Remove drawer under refrigerator.
 30' foot - under lavatory.
 33' foot - under galley against wall.

PLUMBING

TOILET (30' & 33' Models)

Manufacturer: Thetford Corporation
7101 Jackson Road
Ann Arbor, MI 48103
313-769-6000

Canada: Thetford Sanitation Ltd.
2710 Slough Street
Mississauga, Ontario
Canada, L4T 1G3

The RV toilet in your Airstream is a design that has been used for many years.

In normal use, when you are hooked up to city water, both pedals are depressed together. This dumps the sewage and fresh water and flushes down the side of the bowl. Water will continue to run into the bowl for a short time after the pedals are released.

When you wish to conserve water hold the hand-spray head over the bowl and hold down the thumb-operated lever. Now when you depress the pedal all the water is routed through the hand-spray.

CAUTION: When you dump the bowl of the toilet make sure all paper and solids have cleared the slide mechanism before you allow it to close. Failure to do so can cause the groove for the slide to become jammed and the slide will no longer close completely.

If the problem should occur a small nail or bent clothes hanger can be used to "pick" the material out of the groove.

MAINTENANCE

If the bowl-sealing blade does not operate freely after extended use, it may be restored to its original, smooth operating condition by applying a light film of silicone spray to the blade. To clean the toilet use Thetford Aqua Bowl or any other high grade, non-abrasive cleaner. Do not use highly concentrated or high acid content household cleaners. They may damage the rubber seals.

Winterizing

Draining Method

Disconnect water supply line at water valve. Completely drain the water supply line before winter storage.

CAUTION: To avoid damage, when using air pressure to blow water from the lines, be sure toilet valve is in the open position.

CAUTION: If water is frozen in the toilet, do not attempt to flush until with the ice thaws.

CAUTION: Never use automotive type antifreeze.

For Thetford service centers: USA 1-800-521-3032
Canada: 1-888-215-5410

PLUMBING

Toilet (26 Ft Model)

Sealand Traveler Lite Model 111
Sealand Technology, Inc
P.O. Box 38
13128 State RT. 226
Big Prairie, Ohio 44611
(800-321-9886)

The Traveler toilet should be cleaned regularly for maximum sanitation and operational efficiency. You can clean that just as you would a household toilet. **Do not use caustic chemicals, such as drain opening types, as they will damage the seals.**

BOWL CLEANING; for stubborn stains, use Brilliance liquid or toilet bowl cleaner. Sealand manufactures it especially for use with Traveler and Traveler Lite toilets. In certain locations where water is hard, a buildup of the lime may dull the toilet bowl finish. Restore the shine with Brilliance cleaner. If you cannot find Brilliance in your area, contact Sealand or your nearest dealer. If Brilliance is not available, you can also use Bar Keepers Friend® cleanser. It is not necessary to vigorously scrub with either product. Please follow label instructions.

SEAL CLEANING; after an extended time, mineral deposits from hard water can build up under the edge of the rubber bowl seal, resulting in a slow leak down of water from the bowl. To prevent this mineral buildup, periodically clean under the bowl seal with Brilliance cleanser.

WINTERIZING

At the end of the season, the Traveler or Traveler Lite toilet should be winterized for storage, by either draining or using potable water safe antifreeze and the system.

To drain;

1. Thoroughly flush system with fresh water.
2. Empty the holding tank.
3. Shutoff water supply to go to sleep have the toilet and remove inlet waterline.

Do not remove brass cap on bottom of the valve.

4. Press flush lever until all air is drained from the toilet.

To use antifreeze;

1. Drain potable water tank.
2. Add fresh water antifreeze to potable water tank.
3. Flush potable water antifreeze and water makes cheer through toilet into the waste holding tank. Each installation is different so amounts may vary. User discretion is required to assure adequate protection.
4. Empty holding tank.

Note; use non-toxic antifreeze designated for potable water systems.

See the Sealand toilet owner's manual for complete instructions and cautions.

Parts Ordering:

Please contact Sealand at 1-800-321-9886, Monday through Friday, from 8:00 a.m. to 5:00 p.m. for the location of the Sealand Authorized Service Center nearest you, or e-mail Sealand@Sealandtechnology.com. Have toilet model number, serial number, and the part you need (number and description) ready to speed up the ordering process.

PLUMBING

Sealand Technology is ready to assist you in the event service is required. Before calling, please have the following information available.

1. Toilet Model Number
2. Serial Number
3. Part Number, Description, and Quantity.

For the name of the nearest authorized service center please call 1-800-321-9886 between the hours of 8:00 AM and 5:00 PM, Eastern Time.

PLUMBING

STORAGE AND WINTERIZING

When storing your motorhome for a short or long period, use the same precautions as you would in your own home in regard to perishables, ventilation and rain protection. In addition, for prolonged storage periods flush out all the drain lines and the holding tanks. Also, drain the entire water system, including the water heater and the water storage tank. Instructions for draining the water system are explained in the following paragraphs on winterizing.

Twice a year, or after a long storage period, we suggest you take your unit into your Airstream dealer for a check-up and cleaning of the gas operated appliances

Living Area

The main consideration in winterizing is to guard against freezing damage to the hot and cold water systems, the waste drain system (including the traps), the waste holding tanks, the water heater and the batteries. To completely winterize your motorhome follow this procedure:

1. Level the motorhome from side to side and front to rear. Open all faucets.
2. Turn the water pump switch to the OFF position.
3. Open all drain valves. See Drain and High Pressure Water Valves in this section.
4. Follow winterizing instructions for your toilet in the toilet section of this manual.
5. While the water is draining from the system, depress hand spray thumb button on the telephone showerhead and drain all the water. Unscrew the head on spray unit and store.
6. After the water has stopped running from the drain lines, apply at least 60 lbs. of air pressure at the city water inlet. Be sure the toilet valve and all drain valves and faucets are open and pump outlet hose is disconnected. This can be accomplished at a service station and will force any remaining water from the water heater and remove any water which may be trapped in low areas.
7. Pour a cup of non-toxic antifreeze into the lavatory, sink, and tub drains to prevent freezing water in traps.
8. Be sure to open the waste holding tank drain valves, and drain and flush the tanks thoroughly. (This is very important, as the frozen sewage could seriously damage the tank.)
9. Remove water filter canister and dump.
10. Remove the batteries from your motorhome and store in a cool dry place where there is no danger of freezing. It is very important for optimum life of your battery to check it periodically and to keep it fully charged. This is especially true in winter months, when the temperature may drop below freezing. If the period of storage is for 30 days or less, you may turn off the "kill" switch rather than remove the batteries,
Please refer to the battery section for more information on battery maintenance
11. Remove any items (food, cosmetics, etc.) from the interior that might be damaged by freezing, or might damage the motorhome if containers break.
12. If you have an optional icemaker, read and follow the winterizing directions in the manufacturer's owner manual. Open shut-off valve to drain the icemaker at the same time you drain your motorhome. If the motorhome is to be used in freezing weather, do not open valve and use the icemaker.

PLUMBING

For additional winterizing protection, add non-toxic antifreeze (approved for drinking water systems) to your water lines using the following procedure:

1. Reconnect all lines except the hose to the pump inlet port. Close all drain valves (See Step 3)
- *2. Turn bypass valves to bypass position.
3. Attach a length of hose to the pump inlet port. This piece of hose should be long enough for the free end to be inserted into and reach the bottom of the antifreeze container.
4. Dilute the antifreeze solution in accordance with the manufacturer's instructions.
5. Open all water faucets.
6. Insert hose length into the antifreeze container, turn the pump switch on, and run the water pump until the antifreeze solution fills all water lines. Flush toilet. Work shower hand spray while holding down in tub.
7. Shut off the pump and close all faucets.
8. Disconnect the hose length from pump inlet fitting and reconnect water system inlet line.

* The by-pass valves are located under the lavatory cabinet in the 33' model (accessed by removing the lower shelf vertical close-out), under the wardrobe in the 30' model (pull off the small raised panel door held on by pressure latches below the wardrobe door) and under the bedroom wardrobe in the 26' (open the lower door).

For normal operation open valves A and C and close valve B. (Reverse the valves and drain the water heater for winterization).

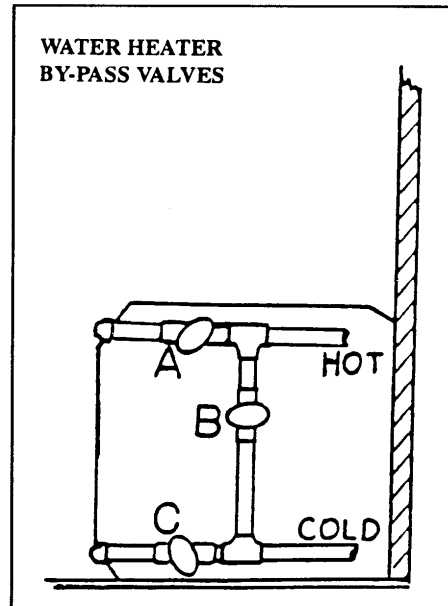

PLUMBING

DRAIN AND WASTE SYSTEM

The drain and waste system of your motorhome includes waste holding tanks made from molded plastic. The MAIN HOLDING TANK enables you to use the toilet for several days away from disposal facilities. The wastewater from the sink, shower, and bath and lavatory drain into the AUXILIARY HOLDING TANK. Each tank has its own dump valve; however, both tanks drain through a common outlet. Therefore, you need to make only one connection when hooking up in a motorhome park with sewer facilities.

Monitor Panel

Check your monitor panel frequently. When the MAIN HOLDING TANK is completely full, sewage cannot be emptied from the toilet bowl. If the AUXILIARY HOLDING TANK is overfilled, drain water will "backup" into the tub and cause an unpleasant cleaning job. Tank one on the monitor panel is the "black" tank and tank two is the auxiliary or "gray" tank. Never drain the tanks at any place other than an approved dumping station.

To empty both tanks, attach the sewer hose by pressing the bayonet fitting onto the outlet adapter and rotate clockwise until it feels solid and secure. Attach the outlet end of the hose to the sewage outlet; making sure that the hose is placed so that it will drain completely. The dump valves are located on the lower rear roadside corner of the motorhome. Pull the dump valve handle out as far as it will go and wait until the tank is drained. If the auxiliary tank is drained after the waste tank, the soapy water will help keep the sewer hose and outlet clean.

The main holding tank must be flushed out until all paper and waste material is removed. Close the dump valve and refill the tank with 5 to 10 gallons of clean water and repeat until clean.

PLUMBING

When Parked and Connected to Sewer Outlet

When you are in a park and connected to a sewer outlet, keep the main holding tank dump valve closed and empty the tank every few days or whenever it becomes almost full. ONLY BY SENDING A LARGE VOLUME OF LIQUID THROUGH THE MAIN HOLDING TANK AT A TIME WILL TOILET PAPER AND OTHER SOLIDS COMPLETELY WASH AWAY.

This practice will avoid the accumulation of solids in the main holding tank, which could lead to an unpleasant cleaning job. Should solids accumulate, close the dump valve, fill the tank about half full with water, then drive the motorhome for a few miles. The turbulence and surging of the water will usually dissolve the solids into suspension so the tank can be drained. Keep the auxiliary tank valve open when connected to a sewer outlet.

Draining the tanks as described will protect them from freezing during storage. When traveling in sub-freezing temperatures, use a winterizing solution designed for RV use. Follow the directions on the container. As this is being written, heated tanks are being considered and may be on your motorhome.

CAUTION: Never put wet strength paper towels or tissues in your holding tank, since they won't dissolve and can "catch" in the mechanism of the dump valve. Colored toilet tissue is slower to dissolve than white. Most RV accessory stores offer tissue, designed for RVs that will completely dissolve.

BLACK TANK FLUSH

On the side of the motorhome is a large utility compartment with a keyed door. A spigot and garden hose female connector is inside. In the utility compartment on the left rear lower side is a water hose connector marked "black tank flush". (Don't mistake it for the exterior water spigot.)

Hook-up a 1/2" or larger water hose and turn it on full force. Within the tank a multiple holed plastic water line will spray the interior surface of the tank. The gate valve should be closed for the first couple of minutes to let some water accumulate in the tank, and then opened to let the water out in a rush. Repeat as needed

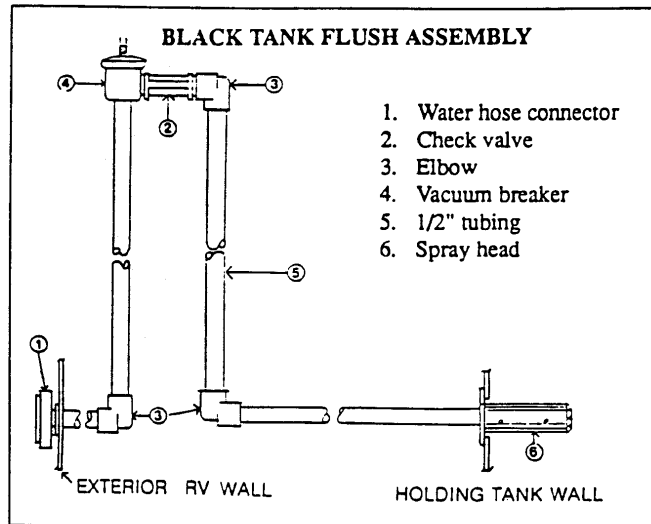

Drain Systems Cleaning

There are many deodorizers on the market in tablet, liquid, and powder form. These not only combat odor, but also stimulate the bacteria that works to dissolve the solids in your tank. Picking a deodorizer with lubricating qualities will help ease the slide valve operation.

The only cleaning agents that can be used without causing harm to the system are household ammonia and tri-sodium phosphate in small quantities. Do not use any product that contains any portion of petroleum distillates. This attacks the rubber seals of your toilet and dump valve. Also, do not use any dish detergent or abrasive cleaners. All products should be marked approved for ABS drainage systems.

When winterizing the drains use only recreational vehicle plumbing type antifreeze. These are sold through your dealer.

ELECTRICAL SYSTEM

BATTERY CONTROL CENTER

The Intellitec Battery Control Center is a centralized power switching, fusing, and distribution center. Power from both the chassis and the coach batteries are feed into the control center box. **All servicing with-in this box should be done only by a qualified Service Technician.** Page H-3 has a drawing of the 12-volt chassis wiring system used in your motor home.

Your motorhome is equipped with three batteries. One battery will be for the engine and the other two batteries (coach) for the interior 12-volt circuits. All batteries are located under the front hood.

The **Engine battery** is used for starting the engine and operating the headlights, taillights, running lights, instrument panel lighting, automotive air conditioning and other accessories. The alternator charges all the batteries while the engine is running. The converter charges all the batteries when the unit is plugged into shoreline.

The **Coach batteries** are used for interior lighting; exhaust fans, generator, water pump, central control panel, entertainment center, optional 12-volt convenience outlets, and the refrigerator when it is switched to 12-volt power. The Intellitec Battery Control Center manual is also in your packet. It has trouble-shooting and wiring information.

The **Intellitec Primary Battery Control Center** is located in the driver's side front exterior lower compartment along with the interior 12-volt fuse panel. 12-volt power is distributed to each of the 12-volt interior circuits of the motorhome from this fuse panel.

The **Battery Disconnect** switches on the panel just inside the main door acts as master switches. When the coach switch is turned to **use** it opens the circuit between the coach batteries and the twelve-volt distribution panel in the primary Battery Control Center. The chassis switch disconnects the chassis battery from the chassis systems except for a few items such as ignition. The coach and chassis batteries are charged by the converter whether the battery disconnect switches are in the use or store position. The generator also charges all batteries when it is running, through the 120-volt city power system that powers the converter.

NOTE: The chassis disconnect switch will not operate with the ignition key on.

The disconnect switches are not intended for everyday use. But if you're going to be away from your coach for more than 3 or 4 days and it's not plugged into 110-volt current just flip the switches off on the way out and you're assured of fresh batteries when you return.

The **converter** is located in the roadside front exterior compartment in the 30 FT. and 33 FT. Models. Remove the front inside panel for access. It is under the front dinette seat in the 26 FT. Model, remove the seat top for access.

The **hydraulic pump** for the leveling jacks is located under the front hood.

There are **two sets of fuses** controlling circuits of Airstream installed equipment in the roadside front exterior compartment. The main interior circuits are fused in the 12-volt distribution panel in and beside the Battery Control Center. The brightly colored fuses pull straight out from the face of the panel. Replacement fuses are available at automotive stores and most service stations. There are diagrams on the lids of both fuse panels.

Another fuse panel for the chassis fuses is located to the left of the steering column. The functions of these fuses are marked directly on the face of the fuse block. See your Chassis Drivers Manual for further information on chassis items. A diagram in this section shows where Airstream picks up power for automotive accessories. The diagrams for these fuse panels are shown later in this section.

ELECTRICAL SYSTEM

12-Volt Operation

The only thing you have to do is make sure the two coach batteries and engine battery does not run down. In normal usage there isn't any problem, since you would normally drive part of the day and be plugged into a campground at night. The alternator charges the batteries when you drive. When you're plugged into city power the converter charges the batteries and carries much of the load.

Some nights you may not find a place to plug into city power. No problem; the batteries total about 210 amp-hours, so you can comfortably run your lights and vents in a normal fashion without depleting the batteries.

If you are not plugged into city power and you're not driving, you'll want to conserve your coach batteries by using as few lights and appliances as possible. The Battery Control Center isolates the engine battery and coach batteries from each other, preventing the coach 12-volt system from drawing down the engine battery. If you notice the lights becoming dim, it's much easier on the batteries if you go ahead and start the engine or generator before the batteries run down.

Interior Lights

Many interior lights have been included in your motorhome to give you almost infinite variable light intensity.

There are two main clusters of light switches. Just inside the main door on the galley end panel are switches for the step, patio light and forward ceiling lights. The forward ceiling lights must have their switches on before the remote switch on the galley end panel will control them.

The second cluster of switches is in the bathroom. They control the bath lights, water heater and water pump. The water pump switch operates in conjunction with the pump switch on the monitor panel. The pump can be turned on or off at either location. The water heater switch marked gas supplies power to the igniter and gas valve. When turned on it will flash red until flame is sensed, then the red light will be extinguished. A second switch operates the water heater on 110-volt power.

The bulbs in the interior lights are all easily replaced if they burn out, Round, exposed bulbs, such as those around the bathroom mirror and reading lights, are replaced by depressing them into their base, then turning to the left about ¼ turn. This will allow them to "pop" out part way so they can be removed.



Warning: If they are difficult to turn, use a folded rag to protect your hand when grasping the bulb in case it should unexpectedly shatter.



WARNING: Always replace the light bulb on an interior or exterior light fixture with the correct bulb for that light. Failure to heed this warning could cause fire, property damage, personal injury, or death.

ELECTRICAL SYSTEM

Primary Battery Control Center Circuit Locations Front Driver's Side Exterior Compartment

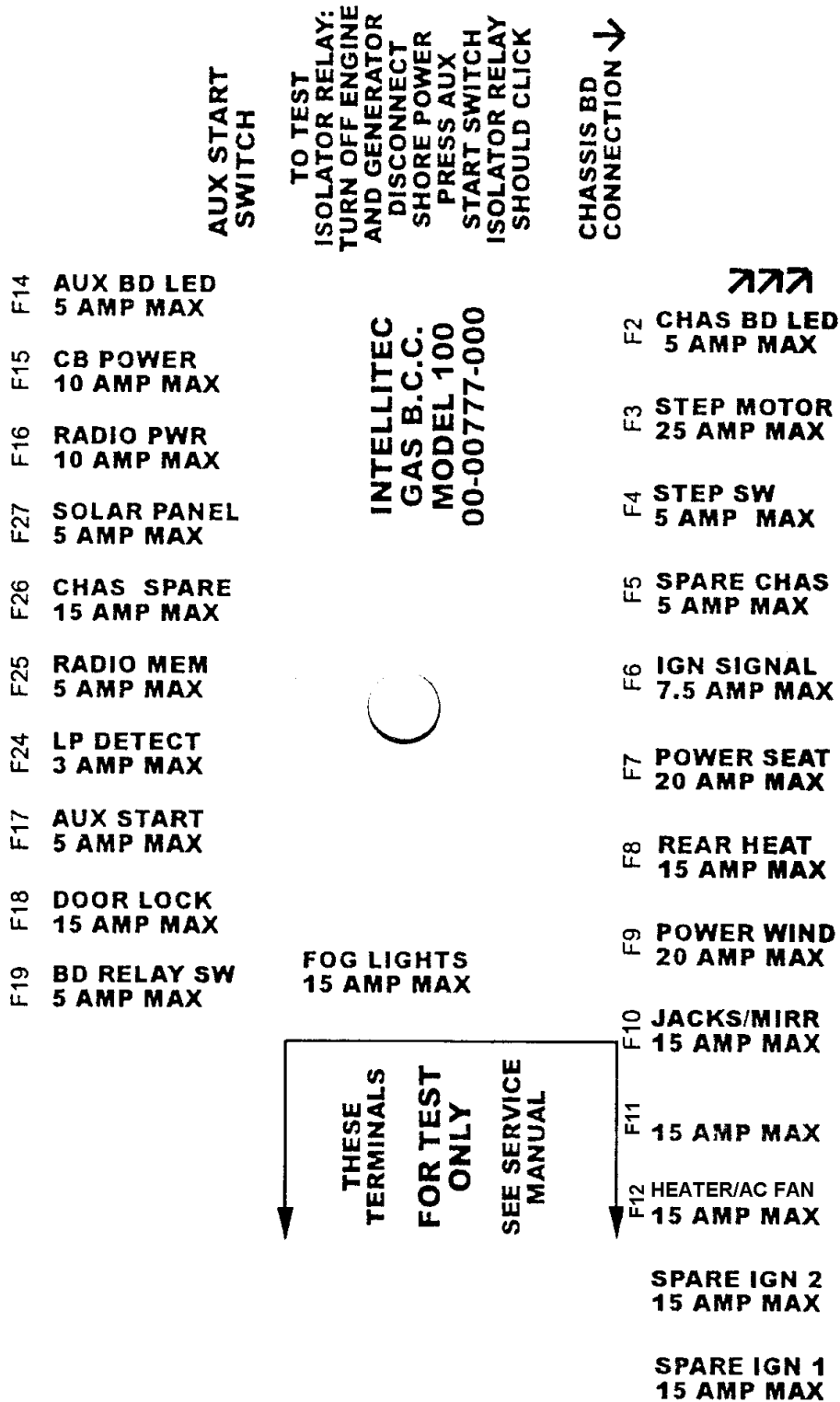

ELECTRICAL SYSTEM

Fuse Panel, Coach Front Roadside Exterior Compartment

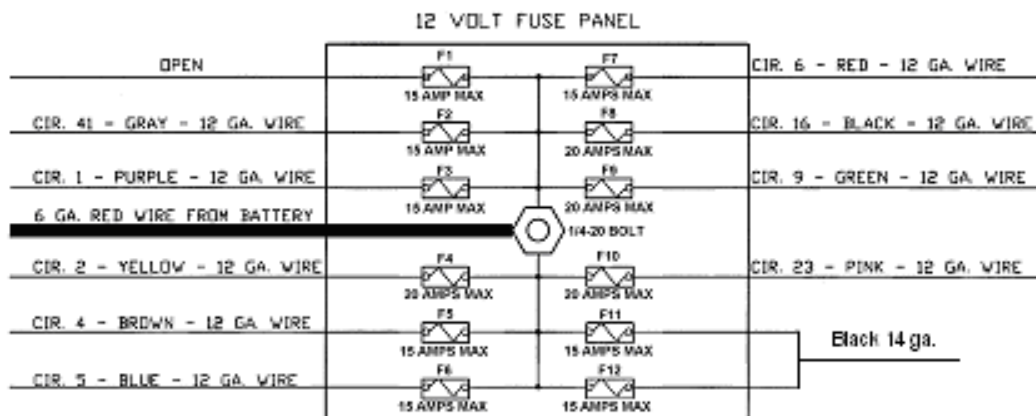

CIRCUIT	COLOR	MAX AMP	DESCRIPTION
Spare		15	
41	Gray	15	Power Awning
1	Purple	15	Bedroom lights, Television, Fan
2	Yellow	20	Bath & vanity lights, furnace, water heater
4	Brown	15	Aisle, galley, under hood, lights
5	Blue	15	Bath fan, refrigerator, TV booster, RS reading lights, Fan
6	Red	15	Storage compartment lights
16	Black	20	Step, patio, dinette, and 1, 2, 3, ceiling lights
9	Green	20	Water pump, range vent and light
23	Pink	20	Docking lights
F-11	Black	30	S/O Motor

ELECTRICAL SYSTEM

26 Ft. LAND YACHT MOTORHOME 12-VOLT CALCULATIONS

FUSES POSITION 1, 15 AMP, SPARE
 Front AC Feed wire 1.00
 Total 8.60 AMPS

FUSES POSITION 2, CIRCUIT 1, 20 AMP, GRAY
 OPTION POWER AWNINGS 5.00 AMPS

FUSE POSITION 3, CIRCUIT 1, 20 AMP, 12 GA. PURPLE
 (2) 1-bulb 10W. Bed Reading Lights 1.60
 1-bulb CS Wardrobe Light 1.44
 #4 Bedroom Fluor. Ceiling Light 1.33
 (1) 2-bulb Wall Lamp 2.00
 Rear TV 5.00
 (1) 2bulb RC Closet Light 2.88
 Fantastic Fan 3.00
 Total 17.25 AMPS

FUSE POSITION 4, CIRCUIT 2, 20 AMP., 12 GA., YELLOW
 Toilet Area Fluor. Light 1.33
 Furnace 9.80
 Water Heater Elec. Ign. 1.00
 (1) 3-bulb Vanity Light 3.50
 Total 15.63 AMPS

NO CIRCUIT 3 USED

FUSE POSITION 5, CIRCUIT 5, 15 AMP., 12 GA. BROWN
 (4) Aisle Lights 1.60
 Under hood Light 1.44
 Galley Overhead Light 1.33
 Total 4.37

FUSE POSITION 6, CIRCUIT 5, 15 AMP., 12 GA. BLUE
 Toilet Area Ceiling Fan 2.00
 Refer Light 1.00
 (2) 10 W. Hal. RS Lounge R/L Lights 1.60
 Fantastic Fan 3.00
 12-volt Booster 0.00

FUSE POSITION 7, CIRCUIT 6, 15 AMP., 12 GA., RED
 (7) Compartment Lights 10.08 AMPS

FUSE POSITION 8, CIRCUIT 8, 20 AMP., 12 GA., BLACK
 (2) Step Lights 2.00
 Patio Light 1.50
 3-Bulb Dinette Light 4.50
 #1, 2, and 3 Fluor. Ceiling Lights 5.10
 Total 12.10 AMPS

NO CIRCUIT 8 USED

FUSE POSITION 9, CIRCUIT 9, 20 AMP., 12 GA., GREEN
 Range Vent and Light 3.20
 Water Pump 10.00
 Total 13.20 AMPS

FUSE POSITION 10, CIRCUIT 23, 20 AMP., 12 GA., PINK
 (4) Halogen Docking Lights 18.33 AMPS

FUSE POSITION 11, 15 AMP., SPARE

FUSE POSITION 12, 15 AMP., SPARE

Battery Charger 3.00 AMPS

TOTAL AMP. DRAW
 1ST 20 AMPS @ 100% = 20.00 AMPS
 2ND 20 AMPS @ 50% = 10.00 AMPS
 67.56 AMPS @ 25% = 16.89 AMPS
 46.89 POWER CONVERTER REQUIRED

107.56 AMPS

ELECTRICAL SYSTEM

30' & 33' LAND YACHT XL MOTORHOME, 12V. CALCULATIONS

FUSE POSITION 1, 15 AMP. SPARE

FUSE POSITION 2, CIRCUIT 41, 15 AMP. 12 GA. GREY

OPT. POWER AWNING 5.00 AMPS.

FUSE POSITION 3, CIRCUIT 1, 20 AMP. 12 GA. PURPLE

(3) 1-BULB 10W. BED. READING LIGHTS 2.40
 1-BULB CS WARDROBE LIGHT 1.44
 #5 BEDROOM FLUOR. CEILING LIGHT 1.33
 (2) 2-BULB WALL LAMPS 4.00
 REAR TV 5.00
 REAR A/C FEED WIRE 1.00

TOTAL 15.17 AMPS.

FUSE POSITION 4, CIRCUIT 2, 20 AMP. 12 GA. YELLOW

BATH FLUOR. LIGHT 1.33
 BATH CEILING FAN 2.00
 FURNACE 9.80
 WATER HEATER ELECTRONIC IGNITION 1.00
 1 -BULB SHOWER LIGHT 1.44

TOTAL 15.57 AMPS.

NO CIRCUIT 3 USED

FUSE POSITION 5, CIRCUIT 4, 15 AMP. 12 GA. BROWN

(4) AISLE LIGHTS 1.00
 UNDER HOOD LIGHT 1.44
 GALLEY OVERHEAD LIGHT 1.33

TOTAL 4.37 AMPS.

FUSE POSITION 6, CIRCUIT 5, 15 AMP. 12 GA. BLUE

REFER LIGHT 1.00
 (2) 10 W. HAL. R. S. LOUNGE LOCKER LTS. 1.60
 (1) 10 W C.S. LOUNGE LOCKER LIGHT 0.80
 FANTASTIC FAN 3.00
 12V. BOOSTER 0.00
 FRONT A/C FEED WIRE 1.00

TOTAL 7.40 AMPS

FUSE POSITION 7, CIRCUIT 6, 15 AMP. 12 GA. RED

(8) COMPARTMENT LIGHTS 11.52

FUSE POSITION 8, CIRCUIT 16, 20 AMP. 12 GA. BLACK

(2) STEP LIGHTS 2.00

PATIO LIGHT 1.50

SHOWER FAN 1.50

2-BULB DINETTE LIGHT 3.00

1, 2, 3, AND 4 FLUOR. CEILING LIGHTS 6.80

TOTAL 14.80 AMPS.

NO CIRCUIT 8 USED

FUSE POSITION 9, CIRCUIT 9, 20 AMP., 12 GA. GREEN

RANGE VENT AND LIGHT 3.20

WATER PUMP 7.00

TOTAL 10.20 AMPS

FUSE POSITION 10, CIRCUIT 23, 20 AMP., 12 GA. PINK

(4) HALOGEN DOCKING LIGHTS 18.33 AMPS.

FUSE POSITION 11, 15 AMP. SPARE

FUSE POSITION 12, 15 AMP. SPARE

BATTERY CHARGER 3.00 AMPS

TOTAL AMP. DRAW: 105.36 AMPS

1ST 20 AMPS @ 100% = 20.00 AMPS.

2ND 20 AMPS @ 50% = 10.00 AMPS.

65.36 AMPS @ 25% = 16.34 AMPS.

46.34 AMPS,

46.34 POWER CONVERTER REQUIRED BY CALCULATION.
 MAGNETEC 7455, 55 AMP. CONVERTER USED.

ELECTRICAL SYSTEM

EXTERIOR WORKHORSE FUSE BLOCK

The 10-amp ALT/START must be a circuit breaker.

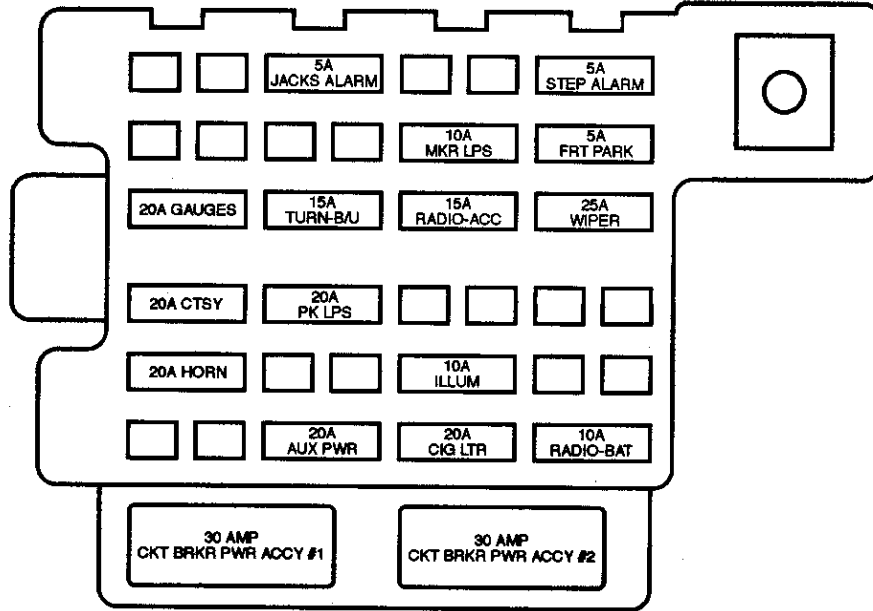

Airstream functions only, see Workhorse manual for all chassis protections.

NAME	SIZE	CIRCUITS PROTECTED
HORN	20A	Horn
CTSY	20A	Dome lights
GAGES	20A	See Workhorse manual
AUX PWR	20A	
PK LPS	20A	Head lamp switch
TURN/BACK UP	15A	Reverse view for camera.
JACKS ALARM	5A	
CIG LTR	20A	Dash 12-Volt outlet
ILLUM	10A	Dash switch lights
RADIO-ACC	15A	Monitor, Step (ign.), Step,
MKR LPS	10A	Clearance lights
RADIO-BATT	10A	
WIPER	25A	Wiper
FRT PARK	5A	Front park lights
STEP ALARM	5A	
PWR ACCY 1	30A	
PWR ACCY 2	30A	

ELECTRICAL SYSTEM

MONITOR PANEL

Micropulse Systems Monitor
CATCON PRODUCTS INC.
817-921-2188
techsupport@catconproducts.com



The MicroPulse System makes use of a single solid-state sensor per tank. The MicroPulse sensor measures the static (head) pressure at the bottom of the tank and transmits this information to the MicroPulse System Monitor. Knowing this pressure value, after a one-time calibration has been performed, the MicroPulse System will calculate and accurately display the tank level in 1/8 increment.

A single sensor is installed on the sidewall of each tank, near the bottom, via a 3/4" female NPT spin-in thread. The sensor is solid state, there are no moving parts to wear or maintain. Because the principle of operation does not involve any electrical current flow through the tanks contents (conducted or induced), the nature of the fluid in the tank is unimportant.

The monitor system has been calibrated at the factory and should never need another calibration. If you feel the system is not operating correctly, please contact CATCON Products or a local Airstream dealer. The following instructions are provided for qualified service technicians.

MONITOR WIRE CONNECTIONS

Red	12VDC, Battery Only
Black	Ground, Battery Only
Purple	Water Pump, 15A, 12VDC
White	LPG Sensor, 90 ohm
Fresh	Fresh Tank Sensor
Gray 1	Gray 1 Sensor
Gray 2	Gray 2 Sensor
Black	Black Sensor

ELECTRICAL SYSTEM

MICROPULSE SYSTEMS MONITOR OPERATION INSTRUCTIONS

This example shows the monitor reporting the following:

Fresh Water = 1/8 to Empty
Gray Water 1 = Empty to 5/8
Gray Water 2 = 3/4
Black Water = Empty to 5/8
LP Gas = 1/4
Battery = Empty to 5/8

**On all diagrams the Letters R=Red, Y=Yellow,
G=Green, Blank=no LED lit.**

NORMAL OPERATION

The MicroPulse Monitor will display the condition of each system at all times. The tri-color LED beside the system will indicate the condition of the system using the following color code.

Fresh Water, LP Gas, Battery are as follows:

Green LED = 3/8 to Full
Yellow LED = 1/4
Red LED = 1/8 to Empty

Gray Water, Black Water are as follows:

Green LED = Empty to 5/8
Yellow LED = 3/4
Red LED = 7/8 to Full

TO OBTAIN EXACT READING

To obtain an exact reading of all systems press and release the status button one time. The monitor will flash the LED beside the system it is about to report. It will then display the exact condition of that system by lighting the bar graph from Empty to Full. The monitor will display the exact condition of each system and then return to normal operation mode.

To obtain an exact reading of an individual system press and release the status button until the LED beside the system that you want the condition of is lit. Release the status button and the monitor will display the exact condition of that system by lighting the bar graph from Empty

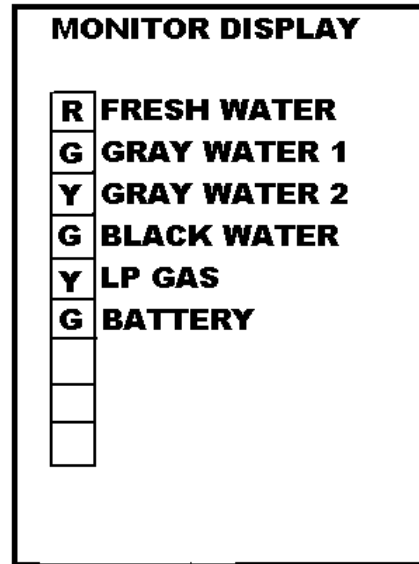

ELECTRICAL SYSTEM

TV ANTENNA

Manufacturer:

Winegard Company
3000 Kirkwood Street
Burlington, Iowa 52601
Phone: 800-843-4741

Raising Antenna to Operating Position

Turn elevating crank in "UP" direction until some resistance to turning is noted. Antenna is now in operating position. Check to make sure switch on front TV jack is on.

Rotating Antenna

Make sure antenna is in "UP" position. Pull down on directional handle with both hands until it disengages ceiling plate and rotate for best picture and sound on television set.

Lowering Antenna to Travel Position

Rotate antenna until pointer on directional handle aligns with pointer on ceiling plate.

CAUTION: Antenna must be in "down" position while traveling to prevent damage.

Turn elevating crank in the "Down" direction until resistance is noted. Antenna is now locked in travel position.

Checking Operation

1. Tune TV receiver to nearest station and rotate antenna for best picture and sound.
2. Turn off switch on power supply. Picture on TV receiver should be considerably degraded with the power off.

DO'S

1. Do check parking location for obstructions before raising antenna.
2. Do carefully raise, lower and rotate - if difficult, check for cause.
3. Do rotate slowly when selecting station and check fine-tuning on TV set to make sure it is properly adjusted.
4. Do lower antenna before moving vehicle.

DON'TS

1. Don't force elevating crank up or down. Check for cause of trouble.
2. Don't rotate directional handle hard against stops.
3. Don't travel with lift in up position.
4. Don't leave lift part way up or down.
5. Don't apply sealing compound or paint over top of base plate or anywhere on lift.

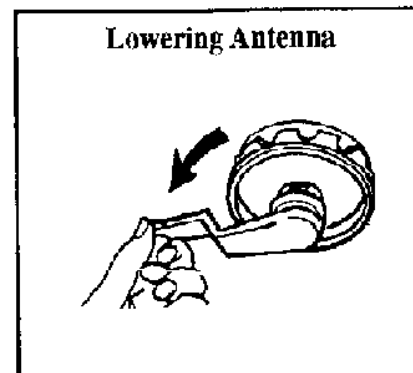
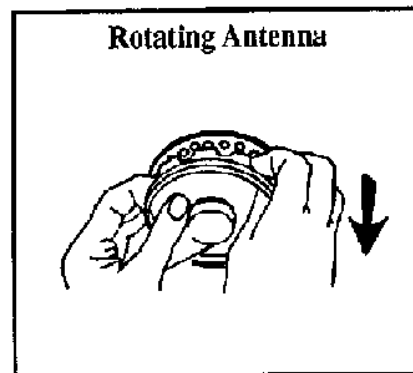
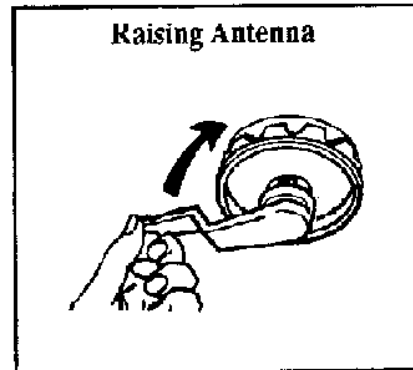

ELECTRICAL SYSTEM

Maintenance

Lubrication

To lubricate the elevating gear apply a liberal amount of silicone spray lubricant to the elevating gear with the lift in the down position, then run the lift up and down a few times to distribute lubricant over gears.

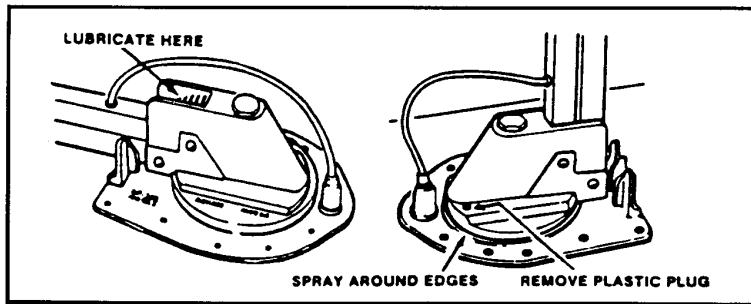

Lubricating Rotating Gear Housing

In the event that rotating the antenna becomes difficult, lubricating the bearing surface between the rotating gear housing and the base plate can restore normal operation. Any spray type silicone lubricant may be used.

Elevate antenna and remove setscrew from rotating gear housing as shown. Spray lubricant into hole and around edges of gear housing. Rotate gear housing until lubricant coats bearing surfaces and antenna rotates freely.

ELECTRICAL SYSTEM

SOLAR POWER

The 5 watt system installed in your motorhome primarily function is as a battery maintainer. Memory functions in radios, locks and the circuit boards in some safety devices each draw power in the milliamp range. If a charge source is not available, even these miniscule power drains will run your chassis batteries down in a few days. Barring an unusual number of cloudy days the solar system will keep your chassis batteries in pretty good condition.

Turning your auxiliary battery switch off at the dash will help maintain the charge in both the chassis and coach batteries.

110-VOLT POWER

The 110-volt system works very much like your home. When you're plugged into city power or start your generator, power is supplied to the 110-volt circuit breakers. The circuit breakers are located under the front of the rear bed in the 30' & 33' and in the top of the roadside wardrobe in the 26'.

If a circuit is over loaded or a short circuit occurs, the breakers will "kick" out. To reactivate the circuits, turn the breaker to off, reduce the load or correct the short, and turn the breaker back to on.

One of the easiest and least disturbing way to reduce the 110-volt load is to turn off the water heater switch in the bathroom. The water heater element draws about 12 amps.

One of the breakers is a GFI (Ground Fault Interrupter) breaker. The intent of this breaker is to sense any loss of ground before a harmful shock could occur, and kick the breaker out. These sensitive breakers are installed in the circuit feeding the outside receptacle, and galley area. These are the areas where the use of water or the wet ground could put a person in danger of shock. Since the GFI breaker is so sensitive, it is not unusual to have it kick out for no apparent reason.

ELECTRICAL SYSTEM

110-VOLT SWITCHOVER BOX

To protect linemen from an unexpected shock the generator must be wired through a switchover box. Two automatic switchover boxes are located in the trunk storage area behind a false panel on the roadside of the area.

Generator/City Power

- A. To 110-volt circuit breakers
- B. To generator 30 amp circuit
- C. To city power

When plugged into city power, the current path is from C to A. When you start your generator and unplug from city power, the points switch and the power flow is from B to A. If you're plugged into city and you start the generator, city power has the priority, so the current flow is C to A.

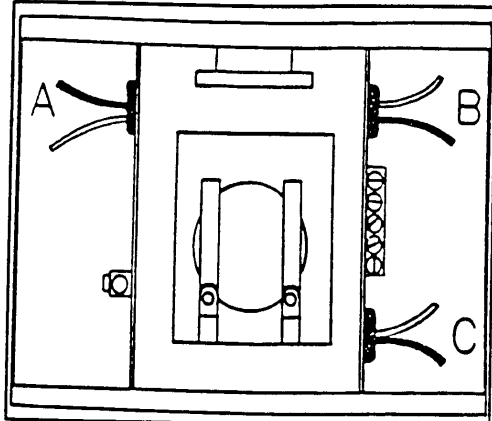

Rear Air Conditioner

- A. To rear air conditioner
- B. Generator 20 amp circuit
- C. To front/rear air conditioner Automatic Energy Select Switch

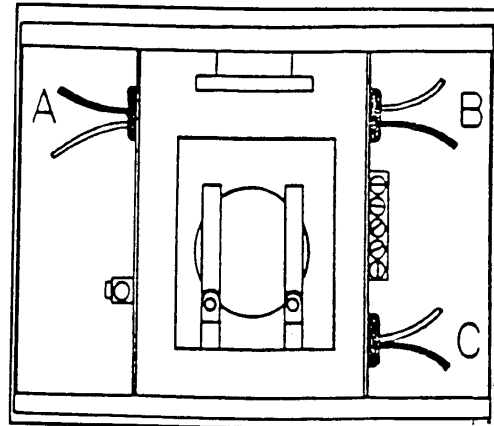

ELECTRICAL SYSTEM

SWITCHOVER BOX (cont.)

When you have the optional 50 amp service, the red wire shown on the following diagram will be providing power to the rear air conditioner whether you are plugged into city power or operating the generator.

SWITCH OVER BOX - 50 AMP

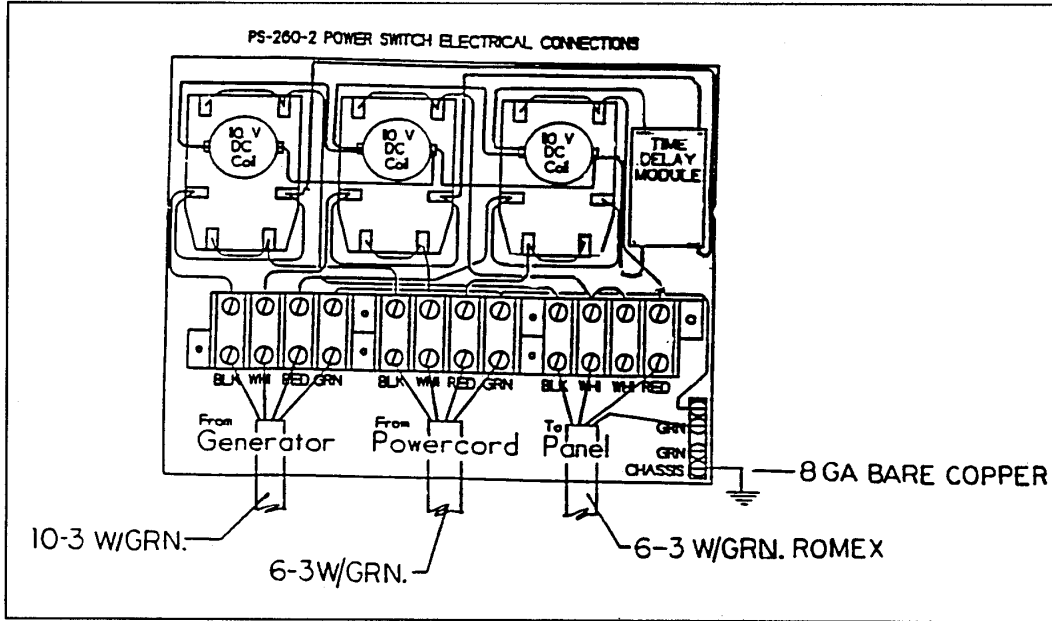

ELECTRICAL SYSTEM

110-Volt Breaker Panel, 30 AMP

30 AMP. 120V. PANEL

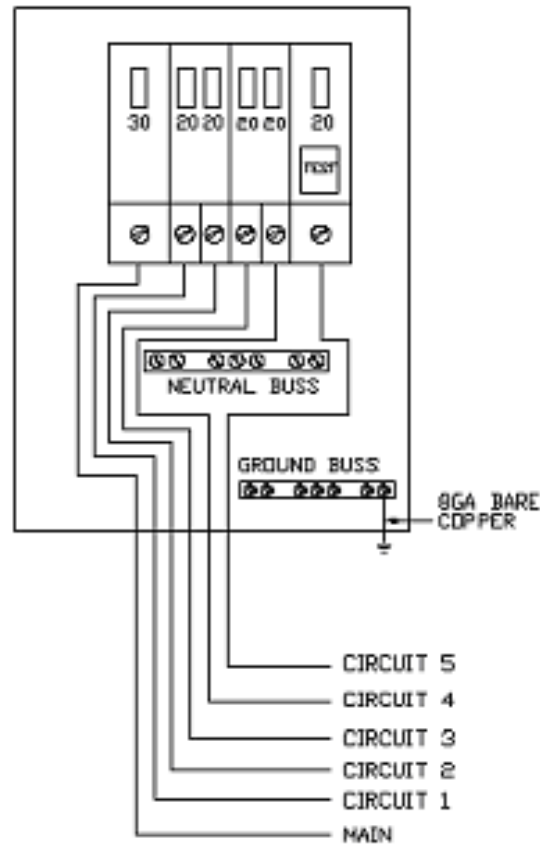

MAIN

CIRCUIT 1, 20 AMP HACR BREAKER, 12-2 RDMEX W/GROUND, AIR CONDITIONER.

CIRCUIT 2, 20 AMP HACR BREAKER, 12-2 RDMEX V/GROUND, BEDROOM AND CONVERTER.

CIRCUIT 3, 15 AMP HACR BREAKER, 12-2 RDMEX V/GROUND, MICROWAVE OVEN.

CIRCUIT 4, 20 AMP HACR BREAKER, 12-2 RDMEX V/GROUND, WATER HEATER.

CIRCUIT 5, 20 AMP GFI BREAKER, 12-2 RDMEX V/GROUND, GALLEY, BATH, OUTSIDE, DINETTE, AND LIVING AREA.

ELECTRICAL SYSTEM

110-VOLT BREAKER PANEL, 50 AMP

110V, BRKR. PANEL-50 AMP

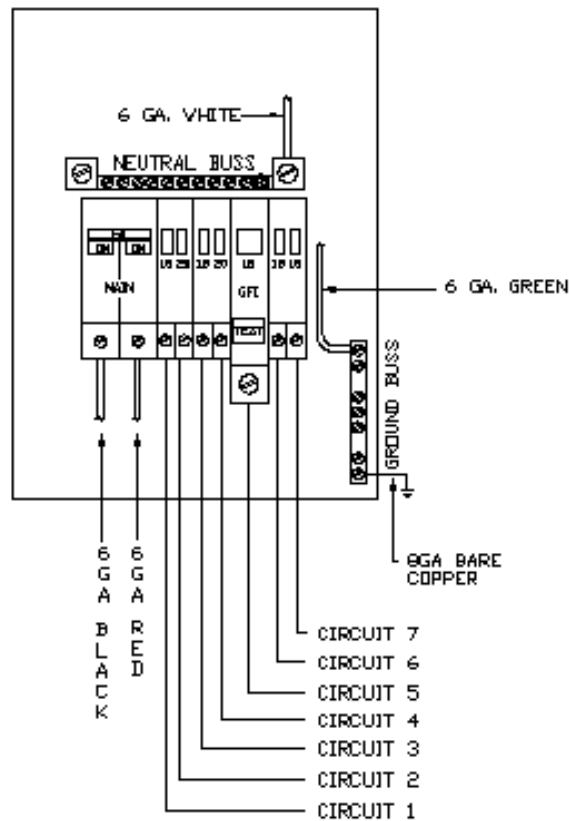

CIRCUIT 1, 15 AMP HACR BREAKER, 12-2 ROMEX W/GROUND, LEG 1, BEDROOM, CONVERTER, LIVING AREA.

CIRCUIT 2, 20 AMP HACR BREAKER, 12-2 ROMEX W/GROUND, LEG 1, FRONT A/C.

CIRCUIT 3, 15 AMP HACR BREAKER, 12-2 ROMEX W/GROUND, LEG 2, MICROWAVE.

CIRCUIT 4, 20 AMP HACR BREAKER, 12-2 ROMEX W/GROUND, LEG 2, REAR A/C.

CIRCUIT 5, 15 AMP GFI BREAKER, 12-2 ROMEX W/GROUND, LEG 1, BATH, OUTSIDE, REFER, AND FRONT TV RECEPT.

CIRCUIT 6, 15 AMP HACR BREAKER, 12-2 ROMEX W/GROUND, LEG 2, GALLEY RECEPT.

CIRCUIT 7, 15 AMP HACR BREAKER, 12-2 ROMEX W/GROUND, LEG 2, GALLEY RECEPT.

ELECTRICAL SYSTEM

Automatic Energy Select Switch (AESS)

Front a/c is priority. Rear a/c will cool, if cool mode is selected, when front a/c has finished its cooling process. Front a/c will come back on as its thermostat detects the need to cool and the rear a/c will shut off. A/C fan (powered by 12-volt) on both units will run even if the other is cooling on the 120-volt circuit. Turn front a/c to fan or off to run rear a/c only.

ELECTRICAL SYSTEM

NOTES

APPLIANCES



Warning: Most LP gas appliances used in recreational vehicles are vented to the outside of the vehicle. Check the exterior areas of your unit for clearance in these areas. Turn all gas operated appliances off when parked close to a gasoline pump, it is possible that gasoline fumes could enter these types of appliances and ignite from the burner flame or automatic igniters, CAUSING A FIRE OR AN EXPLOSION.

AIR CONDITIONER

Manufacturer: Dometic Sales Corporation
2320 Industrial Parkway
P.O. Box 490
Elkhart, IN 46515
Phone: 219-295-5228

Note: Review the air conditioning literature supplied in your Owner's Packet before proceeding.

The roof air conditioner used on Airstream motorhomes is one of the most popular on the market today. In your Owner's Packet is a set of literature covering all operating and maintenance instructions. If the literature is misplaced, please contact the air conditioner manufacturer or your Airstream dealer for replacement. A detailed service guide may be ordered from the manufacturer.

Because of the amount of power drawn by the air conditioners, it is only possible to operate one at a time when plugged into city power. The Intellitec Automatic Energy Selector Switch shown on the previous page controls this function. Front a/c is priority. The rear a/c will cool when the cool mode is selected on it and when the front a/c has finished its cooling process and the thermostat shuts it down. The front a/c will come back on as its thermostat detects the need to cool and the rear a/c will shut off. The A/C fan (powered by 12-volt) on both units will run even if the other is cooling on the 120-volt circuit. Turn the front a/c to fan or off to run the rear a/c only.

Another appliance drawing a lot of current is the microwave. Operating the microwave and an air conditioner at the same time will put your electrical system at the edge of maximum draw. If the air conditioner goes into a "start up" cycle, the additional current will probably cause your main circuit breaker to kick out. If this situation occurs it is best to leave the air conditioner off for the few minutes the microwave is normally operated.

Both air conditioners may be operated when the generator is running or if you have optional 50-amp service. When the generator is running, the front air conditioner is powered through the normal shoreline circuit on the generator 30-amp circuit. The generator powers the rear air conditioner through its 20-amp circuit at the same time.

The voltage to the air conditioner is critical. We commonly refer to 110 or 120 volts, but a check with a volt meter may find voltage much lower. Your air conditioner will probably not function if the current drops below 105 volts. Low voltage is usually associated with older or poorly maintained motorhome parks, but many people have found their homes, built only twenty or thirty years ago, may not be capable of operating the air conditioner on some receptacles. Parking your motorhome so the power cord can be plugged into a receptacle close to the fuse or circuit breaker box can alleviate the problem. Avoid extension cords and adapters whenever possible. If an extension cord must be used, it should be as short and heavy as possible to provide the most current to the air conditioner.

If high temperatures are expected, you should make an effort to park in a shaded area. Starting the air conditioner early in the morning also helps. It is much easier to hold a comfortable temperature than it is to lower the temperature after the interior of the motorhome is already hot.

APPLIANCES

FURNACE (See warning at top of page I-1)

Manufacturer:

Hydro Flame Corporation
1874 South Pioneer Road
Salt Lake City, UT 84104
Phone: 801-972-4621

The manufacturer of the furnace in your motorhome has been well known in the RV industry for many years. The furnace burns LP gas, and is powered by 12-volt current from the battery when there is no shoreline hookup or power converter when plugged into 120-volt shoreline. Operating instructions are located in your Owners Packet. If they should become misplaced new literature can be ordered direct from the manufacturer or your Airstream dealer. The manufacturer also offers a detailed service guide for your furnace.



Warning: Carefully read all the manufacturer's instructions prior to operating. NEVER store flammable material next to the furnace or around its exhaust vent on the side of the motorhome.

If warranty service is required use only a service location recommended by the furnace manufacturer or your Airstream dealer.

APPLIANCES

REFRIGERATOR (See warning at top of page I-1)

Manufacturer: Dometic Sales Corporation 2320
Industrial Parkway P.O. Box 490
Elkhart, Indiana 46514
Phone: 219-295-5228

Review all Dometic Literature supplied in your Owner's Packet or stored in the refrigerator prior to operating.

In an absorption refrigerant system ammonia is liquefied in the finned condenser coil at the top rear of the refrigerator. The liquid ammonia then flows into the evaporator (inside the freezer section) and is exposed to a circulating flow of hydrogen gas, which causes the ammonia to evaporate, creating a cold condition in the freezer.

The tubing in the evaporator section is specifically sloped to provide a continuous movement of liquid ammonia, flowing downward by gravity, through this section. If the refrigerator is operated out-of-level when the vehicle is not moving, liquid ammonia will accumulate in portions of the evaporator tubing. This will slow the circulation of hydrogen and ammonia gas, or in severe cases, completely block it, resulting in a loss of cooling.

Any time the vehicle is parked for several hours with the refrigerator operating the vehicle should be leveled to prevent this loss of cooling. The vehicle needs to be leveled only so it is **comfortable to live in** (no noticeable sloping of floor or walls).

When the vehicle is moving the leveling is not critical, as the rolling and pitching movement of the vehicle will pass to either side of level, keeping the liquid ammonia from accumulating in the evaporator tubing.

OPERATION

The refrigerator requires 12-volt current to operate even if running on LP or 110 volt modes. The 12-volt is used to power the circuit board that directs the refrigerator functions. When running in a mode such as LP, it means the heat source, by far the largest power requirement; to evaporate the ammonia is being provided by an LP Gas burner.

APPLIANCES

RANGE

Manufacturer: Magic Chef
28812 Phillips Street
Elkhart, Indiana 46514
219-264-9578

People using gas ranges in their home will find little difference in the operation of the range in the motorhome. Other customers, used to electric ranges may be a little apprehensive at first; but will quickly gain confidence. The basic operation of the gas ranges have been the same for many years, but please be sure to read all the directions furnished by the manufacturer and located in the Owner's Packet. Excellent service and parts manuals are available from the manufacturer.



Warning: The operation manual for the range is titled "Maytag RV Cooking Appliances". If this has not been provided with your motorhome, contact the manufacturer listed at the top of the page to obtain. Their manual contains specialized warnings and cautions that should be reviewed prior to operating the appliance.

MICROWAVE OVENS

Only federally certified technicians are permitted to service microwave ovens. For this reason the only service instructions contained in this manual are for removal of the complete oven. If you have a microwave problem please contact the appropriate manufacturer.

Dometic Sales Corporation
2320 Industrial Parkway
P.O. Box 490
Elkhart, IN 46515
219-295-5228

Sharp Electronics Corporation
10 Sharp Plaza
Paramus, New Jersey 07652
201-5112-0055

Airstream has used two different methods of holding the ovens in place. The most common is a setscrew configuration where two bolts apply downward pressure on top of the range. The bolts can be found in the cabinet directly above the oven, and out toward the front. Back them out a few turns and the front of the oven can be lifted up and out over the lower ledge.

The second method was to slide a piece of 3/4" pine board under the microwave in front of the rear supports. Once in place screws were run up through the bottom shelf into the 3/4" pine.

You will note neither method makes any holes in the microwave cabinet. The microwave is simply captured in its cabinet. Usually you will be able to move the microwave around in the cabinet, but it won't come out.

APPLIANCES

WATER HEATER (See warning at top of page J-1)

Manufacturer: Atwood Mobile Products 4750
Hiawatha Drive P.O. Box 1205
Rockford, Illinois 61105
Phone: 815-877-7461

Note: Review the water heater literature supplied in your Owner's Packet before proceeding.

 **Warning:** Hydrogen gas can be produced in a hot water system served by this heater that has not been used for a long period of time (generally two weeks or more). Hydrogen gas is extremely flammable. To reduce the risk of injury under these conditions, it is recommended that the hot water faucet be opened for several minutes at the kitchen sink before using any electrical appliance connected to the hot water system. If hydrogen is present there will probably be an unusual sound such as air escaping through the pipe as the water begins to flow. There should be no smoking or open flame near the faucet at the time it is open.

Electronic Ignition

The switches used to operate your electronic ignition water heater are located in the bathroom above the lavatory top. When the switch marked gas is turned on, the red light will come on indicating the "try" mode is in effect. Normally the burner will ignite in just a few seconds, and the light will go out. If your LP system hasn't been used for some time, the system may go into safety lockout (about 20 seconds) before the air is all expelled from the lines. Turning the switch off for 30 seconds, then back on, reinstates the "try" mode.

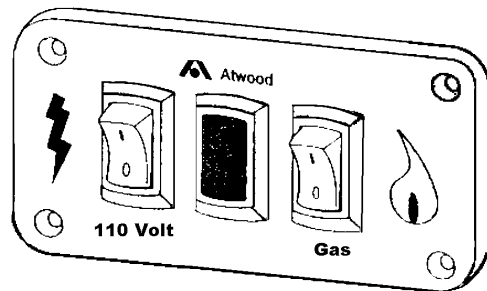

The second switch is used to operate the water heater on 110-volt power. This provides power to the heating element.

CAUTION: DO NOT use the water heater system unless you are sure there is water in the water heater. Open a faucet and see if there is a full stream of water on the hot side. Be sure the water heater by-pass valves are in the normal use position. The water heater may be damaged if you disregard this caution.

The 110-volt element may be operated at the same time as the gas burner. To operate the 110-volt by itself simply turn the electronic gas igniter switch off.

The heating element is 1500 watts so if breakers start to kick out when the air conditioner cycles you may want to turn the switch off the heating element and return to LP gas operation.

SAFETY

If your water system is full and cold and the water heater is ignited, the system can produce pressures as high as 120 psi before the relief valve starts to open. Since the water system normally operates in the 40-psi range the water expansion does put unusual stress on the system. This normally does not cause any problems, but the stress is easily alleviated. As the water is heating just open any faucet and run as little as a cup of water. Just removing this small amount of water reduces the pressure build up significantly.

For fun, watch the sequence of events your family goes through when you park the motorhome **and ignite the water heater. More than likely someone will run water and relieve the pressure without even realizing it.**

APPLIANCES

HIGH VOLUME ROOF VENT (OPTIONAL)

Manufacturer: FAN-TASTIC VENT CORP.
4349 S. Dort Hwy.
Burton, MI 48529
1-313-742-0330
1-800-521-0298

The optional high-volume roof vent system is designed to quickly exhaust stale, hot air and draw in fresh air. It's great to use when the outside temperature really doesn't call for air conditioning, but heat has built up in your coach.

OPERATING INSTRUCTIONS:

1. Rotate 3-speed switch to desired position, 0-off, 1, 2, and 3. The 3-speed switch must be set at 1, 2 or 3 to activate appliance.
2. Rotate thermostat knob toward 40° (cooler) until dome begins operating.
3. When equipped with reverse switch, there is a neutral (off) position. Fan motor will not operate when in/out switch is in its center "off" position. The dome will, however, operate up and down automatically as long as the 3-speed switch remains on.
4. To determine desired temperature setting:
 - a. Use the wall thermometer on furnace thermostat, or any interior temperature indicator.
 - b. Operate fan until interior comfort level is achieved. Rotate thermostat knob toward 110° symbol on label until dome begins closing. You now have the location for normal setting.

The thermostat sensor is calibrated approximately 4°. This minimizes rapid recycling of the unit, once desired temperature level is achieved.

5. The rain sensor built into your fan will prevent excessive rain from entering coach through the open dome. Maintain a setting above (to the right of) "rain override" zone and the dome will close when the sensor becomes wet.

CAUTION: Do not leave coach unattended with thermostat knob set in the "rain override" zone.

6. A rain sensor override is built into this system so you can operate your fan during light to moderate rains. When sensor is wet, rotate fan thermostat knob to coolest position to override sensor. Dome will open and fan motor will start. When sensor has completely dried, rotate thermostat knob back to desired setting for automatic operation.
7. To close dome in extremely hot conditions, rotate thermostat knob right, past 110° symbol to off. Dome will come down.
8. Always allow dome to completely cycle up and down. If dome "hangs up" in partially open/close position, rotate thermostat knob to extreme right and then left position allowing complete cycles down and up. Now reset to original comfort level.
9. When vehicle is in storage, rotate thermostat knob to right (off), after dome closes, turn 3 speed switch to "O" (off).

CLEANING INSTRUCTIONS:

- 1) Turn fan motor OFF.
- 2) Remove 8 painted flathead Philips screws around perimeter of screen insert only.
- 3) Clean screen with soap & water solution and reinstall.

APPLIANCES

AUTOMATIC SATELLITE SYSTEM (Option)

The satellite system comes with an owner's manual. The manufacturer requests that technical and warranty questions be directed to them.

KING DOME SATELLITE SYSTEMS
Technical Support: 1-800-982-9920
Website: www.kingcontrols.com

SPECIFICATIONS

Coach

NOTE: The weights and measurements in this manual are derived from the best information available at time of this manual's publishing. Please refer to the weight information label placed in your unit and your chassis Owner's Manual for weights specific to your RV.

	26 FT	30 FT	30 ft S/O	33 FT
DIMENSIONS				
Exterior Height with Air Conditioner	122"	122"	122"	122"
Interior Head Room	79"	79"	79"	79"
Interior Width	90"	90"	90"	90"
Exterior Length	26'	31' 2"	31' 2"	33' 5"
Exterior Width	96"	96"	96"	96"
Exterior Width S/O extended	N/A	N/A	118"	118"

CAPACITIES

LPG Tank	82 lbs.	90 lbs.	82 lbs.	105 lbs.
Fresh Water Tank	44 Gal.	60 Gal.	60 Gal.	60 Gal.
Grey Water Holding Tank	23 Gal.	36 Gal.	36 Gal.	36 Gal.
Black Water Holding Tank	24 Gal.	34 Gal.	34 Gal.	29 Gal.
Seating Capacity	6	6	5	6
Seating Capacity (lbs.)	924	924	770	924
Sleeping Capacity	4	5	4	5
Sleeping Capacity (lbs.)	616	770	616	770

Hitch Rating: 4000 Lbs. Gross Vehicular Weight, 400 Lbs. Hitch Weight.

The Unloaded Vehicle Weight (UVW), listed on the chart in your coach, is the weight of this motorhome as manufactured at the factory with full fuel, engine oil, and coolants.

Cargo Carrying Capacity (CCC) is equal to the GVWR minus each of the following: UVW, full fresh (potable) water weight (including water heater), full propane weight, and SCWR.



Warning: NEVER exceed the weight ratings of trailer hitch installed on a motorhome. Failure to heed any part of this warning could result in loss of control of the motorhome and towed vehicle or trailer and may cause an accident, serious and/or fatal injury. For specified towed vehicle braking requirements, consult the chassis owner's manual that comes with this vehicle.

SPECIFICATIONS

NOTE: The weights and measurements in this manual are derived from the best information available at time of this manual's publishing. Please refer to the weight information label placed in your unit and your chassis Owner's Manual for weights specific to your RV. The Unit Base Weight (UBW) and the Net Carrying Capacity (NCC) is not the same as the Unloaded Vehicle Weight (UVW) and the Cargo Carrying Capacity (CCC) shown on the Weight Information tag in your vehicle. The UBW and NCC weights are for the base unit with no options and fluids except for fuel on motorhomes. The UVW and CCC on the Motorhome Weight Information tag are weights for the individual vehicle as built with its options and certain water capacities.

CHASSIS	26 Ft.	30 Ft.	30 Ft S/O	33 Ft.
Wheel Base	158.5"	190"	190"	208"
NCC	2,300 Lbs.	3,290 Lbs.	3,330 Lbs.	2,997 Lbs.
GVWR	15,000 Lbs.	18,000 Lbs.	18,000 Lbs.	18,000 Lbs.
GCWR	19,000 Lbs.	22,000 Lbs.	22,000 Lbs.	22,000 Lbs.
UBW	12,700	14,710 Lbs.	14,670	15,023 Lbs.
Gross Axle Ratings Front:	6,000 Lbs.	6,000 Lbs.	6,000 Lbs.	6,000 Lbs.
Gross Axle Ratings Rear:	10,000 Lbs.	12,000 Lbs.	12,000 Lbs.	12,000 Lbs.
Fuel Tank	60 Gal.	75 Gal.	75 Gal.	75 Gal.

Gross Vehicular Weight Rating (**GVWR**): is the maximum permissible weight of this fully loaded motorhome.

Unit Base Weight (**UBW**) is the dry weight of the base unit with the bedroom group/full fuel and w/o options or fluids.

Net Carrying Capacity (**NCC**) is equal to GVWR minus UBW.

Gross Combination Weight Rating (**GCWR**) means the maximum allowable loaded weight of this motorhome and any towed trailer or towed vehicle.

Sleeping Capacity Weight Rating (**SCWR**) is the manufacturer's designated number of sleeping positions multiplied by 154 pounds (70 kilograms).

Gross Axle Weight Rating (**GAWR**): is the value specified as the load carrying capacity of a single axle system, as measured at the tire-ground interfaces



WARNING: The towing vehicle's braking system is rated for operation at GVWR (GROSS VEHICLE WEIGHT RATING), NOT at the GCWR (GROSS COMBINED WEIGHT RATING). A separate functioning brake system is required for any towed vehicles or trailers weighing more than 1000 lbs. (450 kg) when fully loaded. NEVER exceed the GVWR (GROSS VEHICLE WEIGHT RATING), or the GAWR (GROSS AXLE WEIGHT RATING) specified on a motorhome certification label.



WARNING: Do not exceed the Gross Axle Weight Ratings, the Gross Vehicle Weight Rating, or the Gross Combined Weight Rating when loading your vehicle. Failure to heed any part of this warning could result in loss of control of the motorhome and towed vehicle or trailer and may cause an accident and serious injury.



WARNING: READ AND FOLLOW ALL WARNINGS IN THE FUEL SECTION OF YOUR CHASSIS OWNER'S MANUAL BEFORE FUELING YOUR VEHICLE.

INDEX

- Air Conditioner..... C-2, I-1
Alignment..... C-4
Antenna H-10
Appliances..... I-1
Automotive Fuses..... H-1, H-3
Auxiliary Heater..... B-4, C-3
Auxiliary Start Switch..... B-4
- Backup Monitor..... B-4, D-7
Bathroom..... F-2
Battery Control Center H-1
Black-Tank Flush..... G-7, G-19
Bottled Gas..... G-1
Breaker Panel, 110-Volt..... H-15
- Cab Seats..... B-5
Cabinets..... D-10, F-2
Camping..... D-1
Capacities..... J-1
Carbon Monoxide Alarm..... A-6, D-4
Carpet F-1
Caution Introduction
Chairs F-4
Chassis C-1, J-1
Circuit Breakers, 12 Volt..... H-3
Circuit Breakers, 110 volt..... H-12, H-15
City Hook-Up..... D-9, G-7
Cleaning Codes..... F-3
Cleaning, Exterior..... E-1
Condensation..... D-10
Control Panel..... G-18, H-8
Counter Areas..... F-2
Curtains..... F-4
- Dash Air Conditioner..... C-2
Dash Instruments..... B-4
Dimensions..... K-1
Dinette F-4
Door Lock..... B-4, E-1
Drain Hose..... D-9, G-18
Drain Valves..... G-12
Drapes F-4
Driving B-1
- Electrical System..... H-1
Electric Step..... C-10
Escape Windows..... D-1, D-9
Extended Stay..... D-9
Exterior E-1
- Faucets G-8
Fabrics, Cleaning..... F-3
Filter, Water..... G-8
Flooring..... F-2
Furnace J-2
Fuses H-3
- Gas, LP G-1
Generator..... B-4, D-9, H-2, H-12
Ground Fault Interrupter..... H-12, I-1
GVWR B-5, C-3, J-2
GCWR B-5, J-2
- Flooring..... F-2
Heater, Automotive..... B-4, C-2
Hitch Load..... B-5, J-1
Holding Tanks..... B-1, D-7, G-4, G-18, J-1
Humidity..... D-10
- Interior F-1
Inverter B-4
- Keyless Entry..... E-3
- Lavatory, Cleaning..... F-2
Leveling..... C-7, D-7, D-9, D-12
Leveling Jacks..... D-7, H-1
Lights, Interior..... B-4, H-2
Locks A-6, E-1, E-3
Loading..... A-5, B-1, J-2
Lounge F-1
LP Gas Detector..... D-6
LPG System..... G-1
Lug Nuts..... A-6, C-4
- Maintenance Schedule..... A-6
Microwave Ovens..... I-4
Mirrors B-4
Mold Prevention..... D-11
Monitor Panel..... G-30, H-9
- Overnight Stop..... D-7

INDEX

Plumbing	G-1	Toilet	G-12, G-13, G-19
Power Seats	B-5	Towing	B-5, J-2
Range/Oven	I-4	TV Antenna	H-10
Refrigerator	I-3	Tub/Shower	F-2
Roof Ladder.....	E-4	Upholstery	F-3
Roof Vent	I-6	Vent, Power	I-6
Safety Defects, Reporting	A-5	Ventilation	D-10
Safety	B-2, D-1, G-2	Walls	F-2
Sanitizing	G-5	Washing/Waxing	E-1
Seat Belts.....	B-3	Warning.....	Introduction
Service	A-5	Warranty.....	A-1, A-3
Sewer Hose.....	D-9, G-18	Warranty Transfer.....	A-3
Shades	F-1	Warranty Exclusions.....	A-4
Shower Stall	F-2	Water Filter.....	G-8
Slide Out room	D-12	Water Heater.....	I-5
Smoke Alarm.....	D-1	Water Hookup	D-9, G-7
Sofa	F-1	Water Pump.....	G-4, G-5
Solar Power	H-12	Water Strainer	G-8
Spare Tire	C-4	Water System.....	G-4
Specifications	J-1, J-2	Water Valves	G-4, G-12, G-17
Step, Electric	C-10	Weighing	B-1, B-6
Storage	C-16	Wheel Base.....	J-2
Switch Over Box	H-13	Winterizing	G-14
Table	F-4	Winter Traveling	D-7
Tank Capacities.....	J-1		
Tank Drain.....	G-12		
Tank, Holding.....	B-1, D-7, G-4, G-18, J-1		
Tank, Sewage	G-19		
Tank, Water.....	G-4		
Tank, LPG	G-1		
Tires	C-3		
Tire Inflation.....	C-3, C-9		

