

OWNER'S MANUAL

LAND YACHT
MOTORHOME

By Airstream

INTRODUCTION

The Owners Manual for your new Airstream Motorhome is designed to respond to the most frequent inquiries regarding the operation, function and care of the many systems that make modern motorhoming a joy.

Airstream realizes our customers possess varying degrees of expertise in the area of repairing and maintaining the appliances in their motorhome. For this reason, the service and trouble-shooting information found in this manual is directed toward those with average mechanical skills. We also realize you may be more familiar in one area than you are in another. Only you know your capabilities and limitations.

We want you to use this manual, and hope you will find the information contained in it useful; however, should you ever feel you may be "getting in over your head" please see your dealer to have the repairs made.

The operation and care of component parts such as chassis, refrigerator, furnace, water heater and others are explained in this manual. However, you will also find manufacturer's information supplied in a packet included with this manual.

All information, illustrations and specifications contained in the literature is based on the latest product information available at the time of publication approval.

Throughout this manual **CAUTION** and **WARNING** notations are used. Failure to observe "caution" can damage equipment. "Warning" notes the possibility of personal injury if not observed.

Note: If and when new materials and production techniques are developed which can improve the quality of its product, or material substitutions are necessary due to availability, Airstream reserves the right to make such changes.

TABLE OF CONTENTS

A. WARRANTY AND SERVICE

Warranty
Warranty Explanation
Service
Reporting Safety Defects
Maintenance Schedule

B. DRIVING

Loading
Weighing
Safety Check List
Airstream Dash Controls
Trailer Towing & Driving Tips

C. CHASSIS

Component Identification
Dash Air Conditioner/Heater
Fuel System
Tires/Wheels
Electric Step

D. CAMPING

Camping Safety
Smoke Detector
Overnight Stop
Winter Traveling
Extended Stay

E. EXTERIOR

Cleaning
Windows/Doors

F. INTERIOR FURNISHINGS & ACCESSORIES

Lounges & Tables
Fabric Care
Features & Fixtures

G. PLUMBING

LP (Liquid Petroleum) Gas
Water System
Water Pump
Faucets
Toilet
Storage and Winterizing
Drainage System

H. ELECTRICAL SYSTEM

12 Volt system
Batteries
Keyless Entry System
Monitor Panel
TV Antenna
Solar Power

I. 110 VOLT POWER

110 Volt Power
Switch Over Box

J. APPLIANCES

Air Conditioner
Furnace
Refrigerator
Range/Oven
Microwave Oven
Water Heater
Power Roof Vent

K. SPECIFICATIONS

AIRSTREAM, INC.

LIMITED WARRANTY

AIRSTREAM LAND YACHT MOTORHOME

WARRANTY COVERAGE

When you buy a new Airstream Land Yacht Motorhome from an authorized Airstream dealer, Airstream, Inc., warrants the motorhome from defects in material and workmanship as follows:

BASIC WARRANTY PERIOD

This Warranty is for 15,000 miles (20,000 Kilometers) or one year, whichever comes first, beginning when the vehicle is delivered to the first retail purchaser or first placed into demonstrator service. This warranty must have been started prior to the accumulation of 4,000 miles in order to be valid.

ITEMS COVERED

Any part of the motorhome assembled by the factory is covered by the basic **Airstream Limited Warranty** *except* the following items, which are covered by the individual manufacturers.

Two-year Major Component Warranty Addendum

The following major components have two-year warranties provided by their individual manufacturers. Warranty matters will be handled by their respective service points and according to their written policies.

- | | |
|----------------------------|---------------------|
| * Refrigerator | * Power convertor |
| * Range | * Water pump |
| * Furnaces | * Toilet |
| * Water heater | * TV antenna |
| * Microwave | * Stereo |
| * Roof air conditioner | * Tires (pro-rated) |
| * LP tanks | * Awnings |
| * Slide-out room mechanism | * Generator |

This two-year manufacturers' component warranty only applies to vehicles purchased from an authorized dealer, and is only valid to the first retail owner.

OTHER INDIVIDUAL MANUFACTURERS' WARRANTIES

The following items are covered by their individual manufacturers' warranties and will be handled by their respective service points and according to their written policy.

- | | |
|---------------------------------------|-------------------|
| * Batteries | * AC power plants |
| * Video recorder | * Backing monitor |
| * Automotive chassis and power plants | |

These limited warranties do not include failure caused by accident, abuse, normal wear, overload or any cause not attributable to a defect in original material or workmanship of the motorhome or component equipment as installed by the factory.

LIMITED STRUCTURAL WARRANTY

For a period of 24 months or 24,000 miles, whichever comes first, from the date of purchase from an authorized dealer by the first retail purchaser, the **Airstream Limited Warranty Addendum** warrants the motorhome to be free from substantial structural defects in materials and workmanship.

For purposes of clarity, "Structural" shall be limited to the structure of the sidewalls, front and back walls, roof and floor.

All other stipulations in the basic **Airstream Limited Warranty** shall apply.

LIMITATION OF IMPLIED WARRANTIES

All warranties of merchantability and fitness for a particular purpose, whether written or oral, express or implied, shall extend only for a period of one year from the date of original purchase, or 15,000 miles, whichever comes first. There are no other warranties which extend beyond those described on the face hereof and which expressly excludes conditions resulting from normal wear, accident, abuse, exposure or overload. Some states do not allow limitation on how long an implied warranty lasts, so the above limitations may not apply to you.

AIRSTREAM' S RESPONSIBILITY

The basic **Airstream Limited Warranty** applies for a period of one year from the date of original purchase, or 15,000 miles, whichever comes first, and the application date of all warranties is that indicated on the owner's identification card. Defects in items covered under this warranty will be corrected without cost upon the return, at the owner's expense, of the motorhome or defective part to an authorized Airstream dealer.

CARE AND MAINTENANCE

This warranty covers only defective material and/or workmanship; adjustments are made at the factory prior to shipment, and rechecked by the dealer prior to delivery to the customer. Adjustments thereafter become a customer responsibility.

The owner is also responsible for following all recommendations, instructions and precautions contained in the Airstream Motorhome Owner's Manual and the individual manuals furnished by the chassis, appliance and other manufacturers.

INSTALLATIONS NOT COVERED

Airstream, Inc., does not accept any responsibility in connection with any of its motorhomes for additional equipment or accessories installed at any dealership or other place of business, or by any other party. Such installation of equipment or accessories by any other party will not be covered by the terms of this warranty.

IF REPAIRS ARE NEEDED

If your motorhome needs repairs under the terms of the basic **Airstream Limited Warranty**, you should:

1. Take your motorhome to your selling dealer or other Authorized Airstream Dealer.
2. If the dealer is incapable of making the repair, request that he contact the Service Administration Department at Airstream, Inc., for technical assistance.
3. If repairs are still not made, the customer should contact:

AIRSTREAM, INC.
419 W. Pike Street • P.O. Box 629
Jackson Center, Ohio 45334-0629

Attention: Owner Relations Department

Furnish the following information:

- * The complete serial number of the motorhome
 - * Mileage
 - * Date of original purchase
 - * Selling dealer
 - * Nature of service problem and steps or service which have been performed. (The owner may be directed to another dealer at the owner's expense.)
4. If, after taking the above steps, repairs are still not complete, the Airstream owner may request the motorhome be allowed to be brought to the Factory Service Center at the owner's expense.

DEALER REPRESENTATION EXCLUDED

The full extent of the basic **Airstream Limited Warranty** is set forth in detail in the folder, and in the explanation of the basic **Airstream Limited Warranty** covered in the Airstream Motorhome Owner's Manual. Airstream, Inc., will not be responsible for additional representations or implied warranties made by any of its dealers to the extent those representations are not a part of, or are contrary to, the terms and conditions of the basic **Airstream Limited Warranty**.

CONSEQUENTIAL AND INCIDENTAL DAMAGES

Airstream, Inc., will not be responsible for any consequential or incidental expenses or damages resulting from a defect. Incidental expenses include, but are not limited to: travel expenses, gasoline, oil, lodging, meals, telephone tolls, loss of work and loss of use of the motorhome. Some examples of consequential damages would be: stained curtains due to rain leaks or delaminated floor caused by a plumbing leak. *Some states do not allow the exclusion or limitation of incidental or consequential damages, so the above limitation or exclusion may not apply to you.*

WARRANTY TRANSFER

The basic **Airstream Limited Warranty** is transferable to subsequent owners for the duration of the warranty period. Warranty transfer application forms are available from your dealer or the Airstream, Inc., Service Administration Department.

CHANGES IN DESIGN

Airstream, Inc., reserves the right to make changes in design and improvements upon its product without imposing any obligation upon itself to install the same upon its products theretofore manufactured.

This warranty gives you specific legal rights, and you may also have other rights which vary from state to state.

WARRANTY EXPLANATION

Along with your new Airstream motorhome you have purchased the Airstream Limited Warranty. Read your Limited Warranty carefully. It contains the entire agreement with respect to Airstream's obligation on the Limited Warranty on your new vehicle. The terms of the Limited Warranty, and only those terms, will define Airstream's responsibility. When you receive your Limited Warranty file it for safekeeping.

Upon proof of purchase date to any Airstream Dealer Service Center, defects in materials or workmanship will be repaired or replaced without cost to the owner for a period of twelve (12) months from the original purchase date, or 15,000 miles, whichever occurs first. Written warranties of some manufacturers of components of the motorhome will be honored by Airstream for the duration on that manufacturer's warranty.

Items such as motorhome chassis, engine, tires, batteries and generator are serviced by their respective manufacturers and will be handled by their service centers according to the terms of their written policy. Any warranty forms from these manufacturers should be completed promptly, preferably at time of purchase.

Your motorhome chassis is prechecked by its manufacturer before delivery to Airstream. All service to the chassis must be performed by the manufacturer according to the manufacturer's warranty and service policies. Literature is supplied with each Airstream motorhome which gives important information concerning its warranty coverage; however, the Airstream Limited Warranty covers the chassis heater, defrosters, windshield wiper blade, motor, washer, LP gas bottle and gas regulator.

Paint and appearance items which show imperfections should be brought to the attention of your dealer at the time of delivery and during pre-delivery inspection. Normal deterioration by use and exposure is not covered by the Airstream Limited Warranty.

Damage to enameled or porcelain surfaces resulting from abrasion, collision or impact, and broken window glass is not covered by the Airstream Limited Warranty.

The Airstream Limited Warranty Excludes:

Normal Wear:

Items such as water purifier packs, curtains, upholstery, floor coverings, window, door and vent seals may show wear within the one year Limited Warranty period depending upon the amount of usage, weather and atmospheric conditions.

Accident

Damage caused by accident is usually visible, and we strongly urge our dealers and customers to inspect the motorhome upon delivery for any damage caused by accident while being delivered to the dealer, or while it is on the dealer's lot. Damage of this nature becomes the dealer's or your responsibility upon acceptance of the motorhome. GLASS BREAKAGE, whether obviously struck or mysterious, is always accidental and covered by most insurance policies.

Abuse

Lack of customer care and/or improper maintenance, including failure to comply with the terms of the Owner's Manual, or failure to heed proper vehicle operation shown by the dash instruments are not covered by warranty.

Exposure

Deterioration by sunlight is possible to such items as tires, curtains or upholstery. Steel or metal surfaces are subject to the elements, causing rust and corrosion which is normal and beyond the control and responsibility of Airstream.

Overload

Damage due to loading beyond capacity or to cause improper balance is not covered by the Airstream Limited Warranty. The Airstream motorhome body is engineered to properly handle any normal load. There are limits to the amount of load that can be safely transported depending upon speed and road conditions. If these limits have been exceeded the Airstream Limited Warranty will not cover resulting damage. For additional information on the load capacity of your motorhome consult your Owner's Manual or gross vehicle weight rating plate. Each motorhome is aligned during the last quality inspection. These tolerances will only change if the motorhome is subjected to abuse, such as dropping off a sharp berm, striking a curb, or hitting a deep hole in the road. Such damage would be considered as resulting from an accident which risks are not covered under the warranty. Abnormal tire wear and/or wheel alignment resulting from such damage is not covered under the terms of the warranty.

SERVICE

The Airstream Silver Key Delivery Program is an exclusive Airstream program. Before leaving the factory each and every vital part of the motorhome is tested for performance. Each test is signed and certified by an inspector. After the motorhome arrives on your dealer's lot all of these vital parts and systems are again tested. When you take delivery of your new motorhome you will receive a complete checkout.

Please contact your dealer if you need service. Major service under your Airstream Limited Warranty is available through our nationwide network of Airstream Dealer Service Centers. An up-to-date list of Dealer Service Centers has been provided with your new motorhome. This list is current as of the date of publication.

Occasionally dealerships change, or new dealers are added who may not appear on this list. For this reason, it is suggested that you contact your local dealer from time to time and bring your list up to date. He can also provide you with additional copies if you need them.

ALL CENTERS OPERATE ON AN APPOINTMENT BASIS FOR THE UTMOST EFFICIENCY.

When you require service from the Airstream Factory Service Center or a Certified Dealer Service Center please contact the service manager for an appointment, and kindly inform him if you are unable to keep the appointment date or wish to change it.

Service may be arranged at the Factory Service Center by contacting the Service Coordinator at:

Airstream Factory
Service Center
419 W. Pike Street • P.O. Box 629
Jackson Center, Ohio 45334
Phone: 937-596-6111

You Should Also be Aware of the Following:

Airstream is not responsible for any consequential or incidental damages incurred as a result of any defect. Consequential damages include, but are not limited to, travel expenses, gasoline, oil, lodging, meals, telephone tolls, loss of work and loss of use of the motorhome.

In the event of a defect, the owner must take all reasonable corrective action to lessen the damages which might result from such defect. Airstream will not be responsible for damages which could have been avoided.

Airstream's responsibility is defined solely by the Airstream Limited Warranty and Airstream is not responsible for or bound by representations or warranties made by any of its dealers.

Your Airstream Limited Warranty is transferable to subsequent owners of the motorhome, but only for the duration of the warranty period. Warranty transfer application forms are available from your dealer or the Airstream factory.

REPORTING SAFETY DEFECTS

If you believe that your vehicle has a defect which could cause a crash or could cause injury or death, you should immediately inform the National Highway Traffic Safety Administration (NHTSA) in addition to notifying Airstream, Inc.

If NHTSA receives similar complaints, it may open an investigation, and if it finds that a safety defect exists in a group of vehicles, it may order a recall and remedy campaign. However, NHTSA cannot become involved in individual problems between you, your dealer, or Airstream, Inc.

To contact NHTSA, you may either call the Auto Safety Hotline toll-free at 1-800-424-9393 (or 366-0123 in Washington, D.C. area) or write to: NHTSA, U.S. Department of Transportation, Washington, D.C. 20590. You can also obtain other information about motor vehicle safety from the Hotline.

MAINTENANCE SCHEDULE

Note: See chassis and appliance manufacturer's literature for further information.

EVERY 1000 MILES OR 30 DAYS

Escape Window	Check operation of latches and upper hinge
Smoke Alarm	Test and replace battery as required
Tires	Check tire pressure (65 psi)
GFI Circuit Breaker	Test and record

EVERY 5000 MILES OR 90 DAYS

Exterior Door locks	Lubricate with dry graphite
Exterior Hinges	Lubricate with light household oil
LPG Regulator	Check bottom vent for obstructions
Main Door Striker Pocket	Coat with paraffin
Wheel Lug Bolts	Torque to 177 ft. lbs.
Range Exhaust Hood	Clean fan blades and wash filter
Roof Vent Elevator Screws	Lubricate with light household oil
Main Door Step	Lubricate moving parts and check

EVERY 10,000 MILES OR 6 MONTHS

Exterior	Clean and wax
Carbon Monoxide Alarm	Vacuum exterior only

EVERY YEAR OR 12,000 MILES

Battery	Clean, neutralize and coat terminals with petroleum jelly
LP Tank	Have purged by LP supplier
Seams	Check seal on exterior seams, windows, lights, and vents. Reseal with Kool Seal or equivalent as needed.

DRIVING

LOADING

Below is a sample of the weight information chart provided in all Airstream vehicles. This information can be found in your vehicle on the back of the first wardrobe door on the curbside of the vehicle about 60" up from the floor.

MOTORHOME WEIGHT INFORMATION: CONSULT OWNER'S MANUAL FOR SPECIFIC WEIGHING INSTRUCTIONS AND TOWING GUIDELINES.

MODEL		GVWR
UVW	NCC	GCWR

THIS MOTORHOME IS CAPABLE OF CARRYING UP TO _____ **GAL.**

OF FRESH WATER (INCLUDING WATER HEATER) FOR A TOTAL OF _____ **LBS.**

REFERENCE: WEIGHT OF FRESH WATER IS 8.33 LBS/GAL; WEIGHT OF LP GAS IS 4.5 LBS/GAL (AVERAGE).

GVWR **GROSS VEHICLE WEIGHT RATING** MEANS THE MAXIMUM PERMISSIBLE WEIGHT OF THIS MOTORHOME. THE GVWR IS EQUAL TO OR GREATER THAN THE SUM OF THE UNLOADED VEHICLE WEIGHT PLUS THE NET CARRYING CAPACITY.

UVW **UNLOADED VEHICLE WEIGHT** MEANS THE WEIGHT OF THIS MOTORHOME AS BUILT AT THE FACTORY WITH FULL FUEL, ENGINE OIL, AND COOLANTS. THE UVW DOES NOT INCLUDE CARGO, FRESH WATER, LP GAS, OCCUPANTS, OR DEALER INSTALLED ACCESSORIES.

NCC **NET CARRYING CAPACITY** MEANS THE MAXIMUM WEIGHT OF ALL OCCUPANTS INCLUDING THE DRIVER, PERSONAL BELONGINGS, FOOD, FRESH WATER, LP GAS, TOOLS, TONGUE WEIGHT OF TOWED VEHICLE, DEALER INSTALLED ACCESSORIES, ETC., THAT CAN BE CARRIED BY THIS MOTORHOME. (NCC IS EQUAL TO OR LESS THAN GVWR MINUS UVW).

GCWR **GROSS COMBINED WEIGHT RATING** MEANS THE VALUE SPECIFIED BY THE MOTORHOME MANUFACTURER AS THE MAXIMUM ALLOWABLE LOADED WEIGHT OF THIS MOTORHOME WITH ITS TOWED TRAILER OR TOWED VEHICLE. CD-126

***WARNING - Do not exceed the hitch capacity of 400 load and 4000 lb. tow.**

The motorhomes have large fluid tanks and lots of storage areas. It gives you great flexibility in loading. With flexibility comes responsibility. If you want to load down all the storage compartments the amount of fluids will have to be reduced.

Do you really want to carry 750 pounds of water to an RV park 1,000 miles away and then hook up to a city water supply anyhow? Even if you're going to the "boondocks" you can usually fill your water tank shortly before entering the area. Just reducing your load by 10 gallons of water lets you carry an awful lot of fishing and camping gear.

WEIGHING

The UVW, unloading vehicle weight, given in the chart above is the weight of a motorhome with an average number of options. To find the actual weight of your vehicle it must be weighed on scales. The most common are those used by states to weigh trucks along the highway. In rural areas grain elevators are a good source and another would be at gravel pits. If you have trouble locating scales a call to your State Highway Patrol will usually find them very cooperative in assisting you.

SAFETY CHECK LIST

Your Airstream motorhome should be given a thorough safety check before a trip. Regular use of the following list will provide safe operation of your motorhome and will help you spot any malfunctioning equipment and correct the problem as soon as possible. The list is to help you and may not be all inclusive.

Failure to heed many of the following items may cause damage to the vehicle or personal injury.

EXTERIOR CHECK LIST (BEFORE ENTERING VEHICLE)

1. Check condition of tires for proper inflation.
2. Turn off LPG valve on LPG tank.
3. Check that sewer connection, all external compartments and filler openings are properly stowed or closed and/or locked.
4. Check that items stored on exterior of vehicle are securely tied down.
5. Would any items stored on exterior of vehicle present a clearance problem?
6. Lower and secure awnings/TV antenna.

INTERIOR CHECK LIST (BEFORE DRIVING OFF)

1. It is important that the main door and cab door be completely closed and locked during travel. As an added precaution we recommend the dead bolt also be locked on the main door.
2. Turn off living area water pump.
3. Check that refrigerator door is fastened.
4. Check that nothing heavy is stored in overhead or high cabinets which could fall out and cause injury. Heavy items should be stored in low cabinets.
5. Stow folding and pedestal tables.
6. Check that counter tops, range top, credenza tops and shelves are clear of even small items that could become projectiles in an accident.
7. Do not cook while under way. Hot food or liquid could scald due to a sudden stop or accident.
8. Be sure all LPG controls on furnace, range/oven and gas/electric refrigerator are turned off.
9. Check that any internal stowage is securely held in place.
10. Check that lights and switches are set in positions safe for travel.
11. Adjust the driver's seat so that you can easily reach and operate all controls. Make sure seat is locked in position. Do not adjust driver's seat swivel or fore and aft mechanism while vehicle is moving. The seat could move unexpectedly causing loss of control.
12. Check that front passenger's seat is locked in position - both fore and aft adjustment and swivel mechanism.
13. Check rear view mirror adjustment, inside and outside. Adjust curtains if necessary for maximum visibility.
14. Fasten lap belts.
15. Check that step light goes out and that electric step has retracted.

SAFETY SEAT BELTS

In the forward driver's area of the motorhome, safety seat belts are provided for the use of the driver and the right front passenger. Safety belts are available for other seats. It is strongly recommended that all occupants remain seated with their safety belts firmly attached while the motorhome is in motion. The driver should adjust his seat so that he is able to reach all controls easily with the belt on, especially able to use all the travel on the foot brake. The belt should be placed as low as possible around the hips to prevent sliding out from under them in case of accident. This places the load of the body on the strong hip bone structure instead of around the soft abdominal area. Two people should never try to use the same seat belt.

WARNING: Children must be secured in a Federally Approved Child Restraint Device. Failure to use proper restraints can result in severe or fatal injuries in case of accidents.

Child restraint devices are designed to be secured with lap or lap/shoulder belts. All instructions supplied by the restraint manufacturer must be followed. Statistics have shown children are safer when properly restrained in a rear seating position than in a front seating position.

Often the children traveling in motorhomes are grandchildren. There are times when our love for grandchildren makes us hesitate to properly supervise their actions. Don't hesitate when it comes to their safety. Make sure they are properly restrained.

CHILDREN HAVE LOVED ONES TOO...IF YOU WON'T BUCKLE UP FOR YOURSELF, BUCKLE UP FOR THEM.

DASH SWITCHES - AIRSTREAM*

- **Door Lock** - The main door can be locked or unlocked from the drivers seat. Remember to hide an extra door key on the exterior in case of unexpected battery failure.
- **Auxiliary Battery** - The auxiliary start switch is intended to be used if the engine battery becomes too discharged to turn the engine over. To operate, hold the switch in the start position, then use the ignition switch in a normal fashion. Operating the auxiliary start switch closes the points on a large solenoid, tying all three vehicle batteries together for increased starting power.
- **Generator Switch** - The remote generator switch on the dash allows the driver to start or stop the generator without leaving the driver's seat. It should be noted a built-in time delay allows the generator to reach full operating speed before 120 volt current is provided to the coach.
- **Rear Heat** - This switch is two speed and controls the fan on the rear engine heater by the door. The heat source is from the radiator so heat will only be available when driving.
- **Rear Camera** - The rear view monitoring camera has two positions. One will show the rear bumper and operating the switch tilts the camera to view further back.
- **Driving Lights** - To operate the driving lights the regular head lights must be turned on first.
- **Defrost Fans** - In cool, damp weather these fans really help to clear the large windshields. This switch turns them on and off and each fan has its own switch to operate the oscillating feature.
- **TV Speaker** - This switch transfers the TV audio to the multiple radio speakers.
- **Aisle Lights** - The low aisle lights will allow passengers to converse without using overhead lights that could be bothersome to a driver at night.
- **Galley Light Switch** - Some drivers like to be able to turn lights on and off for their passengers. If this doesn't interest you, simply leave the switch on and the galley light will function with its own switch.
- **Docking Lights** - The docking lights illuminate the area at the side of the motorhome and are intended for use when parking in a campground at night.
- **Inverter** - This switch controls a relatively small inverter wired into the front television. Use it **only** when you want to watch the front television and you're **not** plugged into 110 volt power.
- **Exterior Mirrors** - Move center switch to R or L. The four perimeter switches will then move the right or left mirror in the direction indicated.
- **Rear Monitor** - When the ignition key is turned to the accessory or ON position, the power will be supplied and the monitor will be in the standby condition.

When you set the gear lever to the R (reverse) position with the POWER switch released (STANDBY), the monitor will be automatically turned on and the picture will be displayed on the monitor.

To see rearview when not in reverse, depress the power button to ON.

Please review the Rearview Monitor Manual provided by Sony and placed in your Silver Key notebook.

*Some items described may be optional equipment.

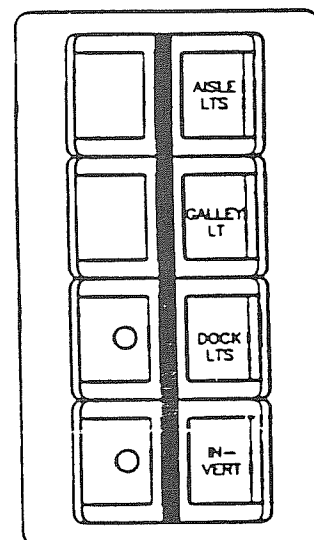
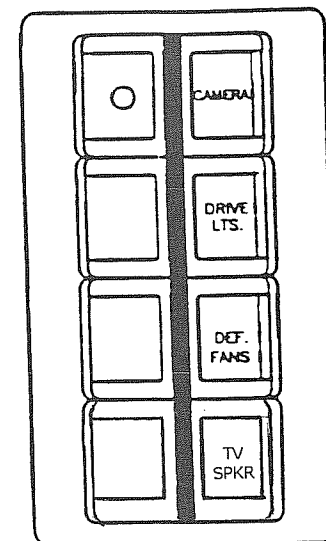
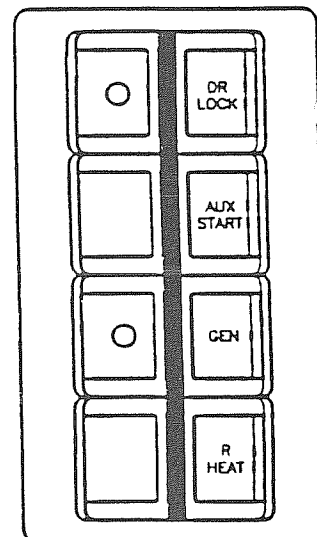

CAB SEATS

Besides the normal power seat control there are two additional finger levers. One allows the seat to recline and the other will let the seat rotate.

CAUTION: Revolving the power seat completely around will pull the wiring apart. The seats should only be swiveled toward the center of the vehicle. If the wires are loosened they can be reconnected by following the color code: Red to red, green to green, etc. On some models the wires will be on a plug that can be reattached.

TRAILER TOWING AND DRIVING TIPS

Since this vehicle is designed and intended to be used primarily as a load carrying vehicle, towing a trailer will affect handling, durability and economy. Maximum safety and satisfaction depends upon proper use of correct equipment and avoiding overloads and other abusive operation.

CAUTION:

The maximum towing capacity varies according to the size of the motorhome. Following is a list of these maximum weights:

The total weight of the motorhome and trailer must not exceed the GCWR listed on previous pages.

Vehicles should be properly equipped for towing trailers. Information on trailer hauling capabilities and special equipment required may be obtained from your Airstream dealer.

To assist in attaining good handling of the vehicle/trailer combination it is important that the trailer tongue load be maintained at approximately 10% of the loaded trailer weight, but not to exceed 400 lbs. Tongue loads can be adjusted by proper distribution of the load in the trailer, and can be checked by weighing separately the loaded trailer and then the tongue.

When towing trailers, tires should be inflated to the highest pressures shown on the information plate attached to the dash of your motorhome. The allowable passenger and cargo load (GVW) of this vehicle is reduced by an amount equal to the trailer tongue load on the trailer hitch.

Trailer brakes are required on axles of trailers over 1,000 lbs. loaded weight.

CAUTION:

Considerable damage will occur if the motorhome is improperly lifted for towing purposes. Only qualified professional wrecker service companies with proper equipment should be used.

The most common equipment is called "reach underhooks". These allow the tow operator to lift on the front suspension of your motorhome without damaging the bumper or other body parts. Another choice is a wheeled dolly. In these the front tires sit in a cradle supported by its own wheels. The tow operator should be told the weight of your vehicle is close to 5,000 lbs. on the front suspension so they can be properly prepared when they reach you.

On vehicles with hydraulically operated park position, it may be necessary to remove a drive shaft before towing. Further information is available in your Chevrolet Owners Manual.

NOTES

CHASSIS

The Airstream motorhome is built on a Chevrolet chassis. Operation of the engine and other related components is discussed in the Chevrolet Owners and Drivers Manual supplied with each coach.

If repairs are needed it can be difficult to determine which parts of the chassis are warranted by Chevrolet, and which are Airstream's responsibility. The following list shows the major components of the chassis and the company responsible for their servicing.

Chevrolet (P-30 Forward Control, Motorhome Chassis)

Engine	Turn Signals
Transmission	Suspension, including Front Air Bags
Brakes	Drive Axle and Hubs
Steering Assembly	Rear Shocks
Front Spindle, Bearings	Automotive Fuse Panel
Steel Wheels	Parking Brake
Alternator	Electric Fuel Pump
Cruise Control	

Airstream

Auxiliary Heater	Leveling Jacks
*Dash Air Conditioner/Heater	Aluminum Wheels
Windshield Wipers	Air Horn
	Isolator

*The warranty on the dash air conditioner/heater can be confusing. Chevrolet provides and installs the air conditioning compressor, condenser, dryer, dual cooling fans and associated plumbing. Airstream provides and installs the blower, evaporator, dash control heater core and heater hoses. All venting and duct work is Airstream's.

The above list covers almost all of the chassis components. If you need further clarification or information contact the Airstream Customer Relations Department at 937-596-6111. If you wish to write the address is:

Airstream, Inc.
419 W. Pike Street • P.O. Box 629
Jackson Center, Ohio 45334

DASH AIR CONDITIONER/HEATER

Acme Radiator Air Conditioning, Inc.
17103 St. Rd. 4E
Goshen, Indiana 46526
800-552-2263

OPERATION

The dash heater control is a General Motors design and very similar to many automobiles.

The upper slide bar marked "cold-hot" controls the amount of hot water flowing through the heater core. When the maximum air conditioner button is depressed, inside air is circulated through the evaporator to obtain the utmost in cooling. The two buttons marked vent and bi-level draw outside air through the evaporator. If you desire just fresh air throughout the vent or bi-level, just pull the button out after it's been depressed and this will disengage the air conditioning.

SERVICE

Acme has requested you to call them on the 800 number listed above should you experience any service problems. They are usually able to help get any repairs needed at an air conditioner repair facility close to your location.

The following pages include wiring diagrams and vacuum line diagrams.

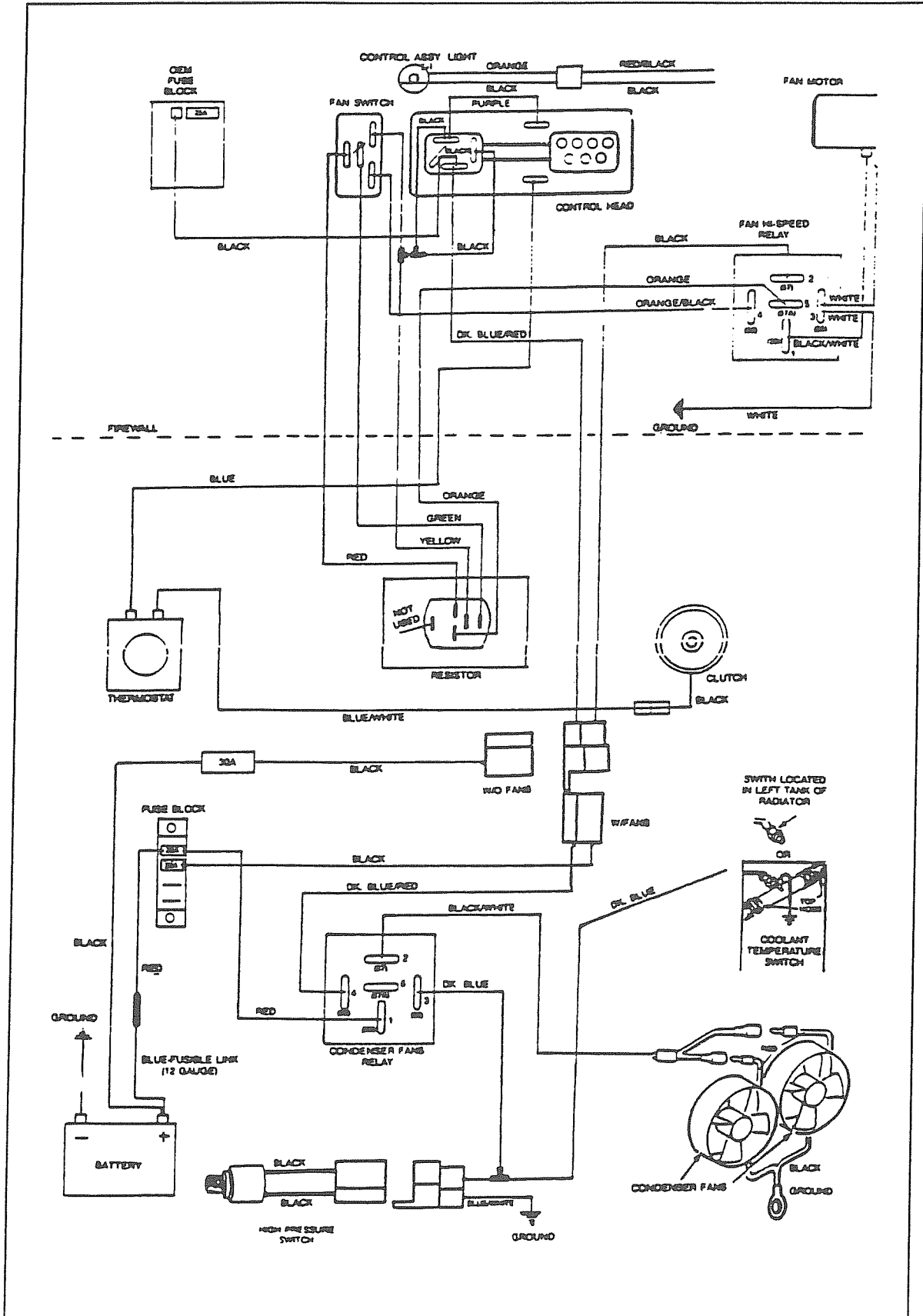

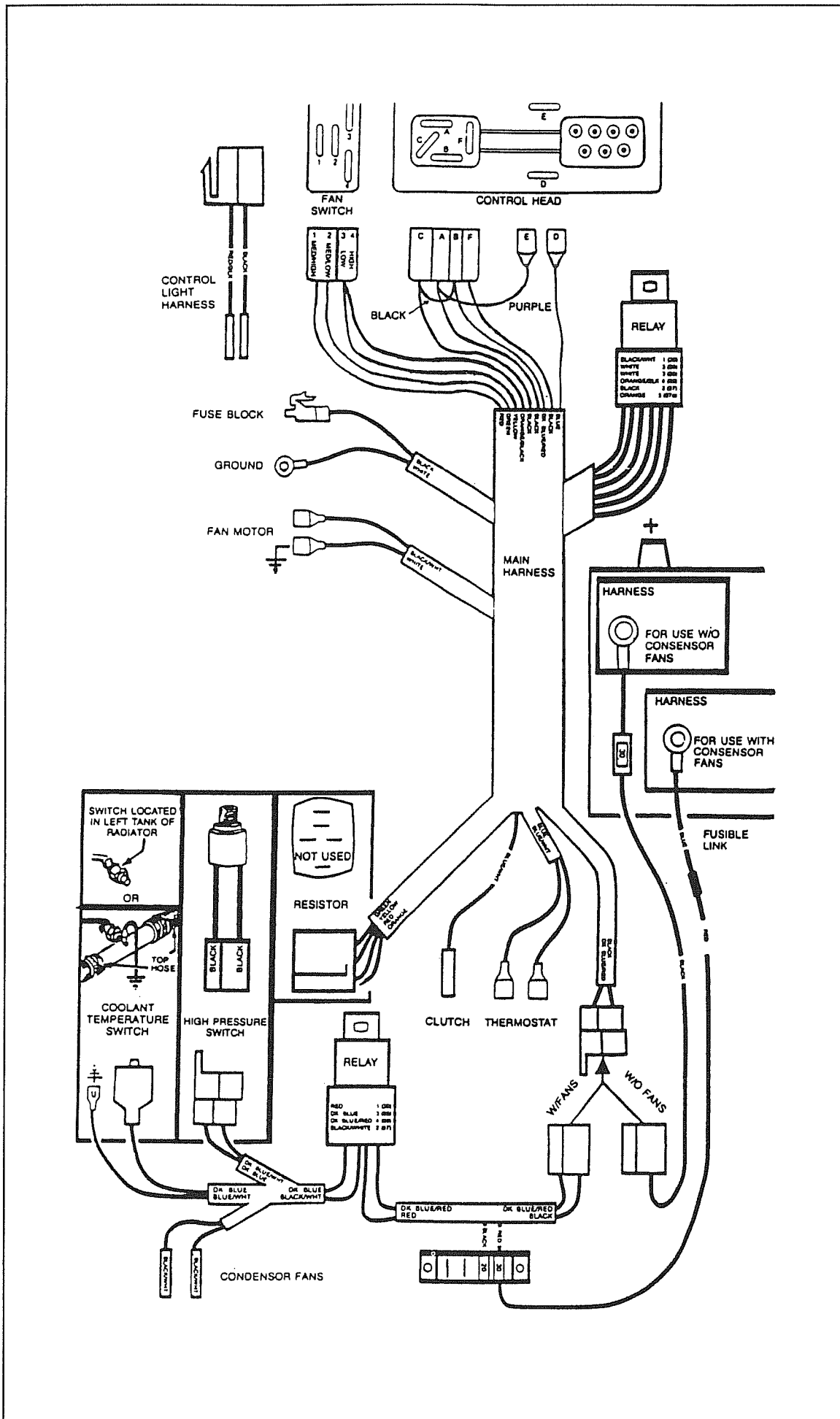

VACUUM SCHEMATIC

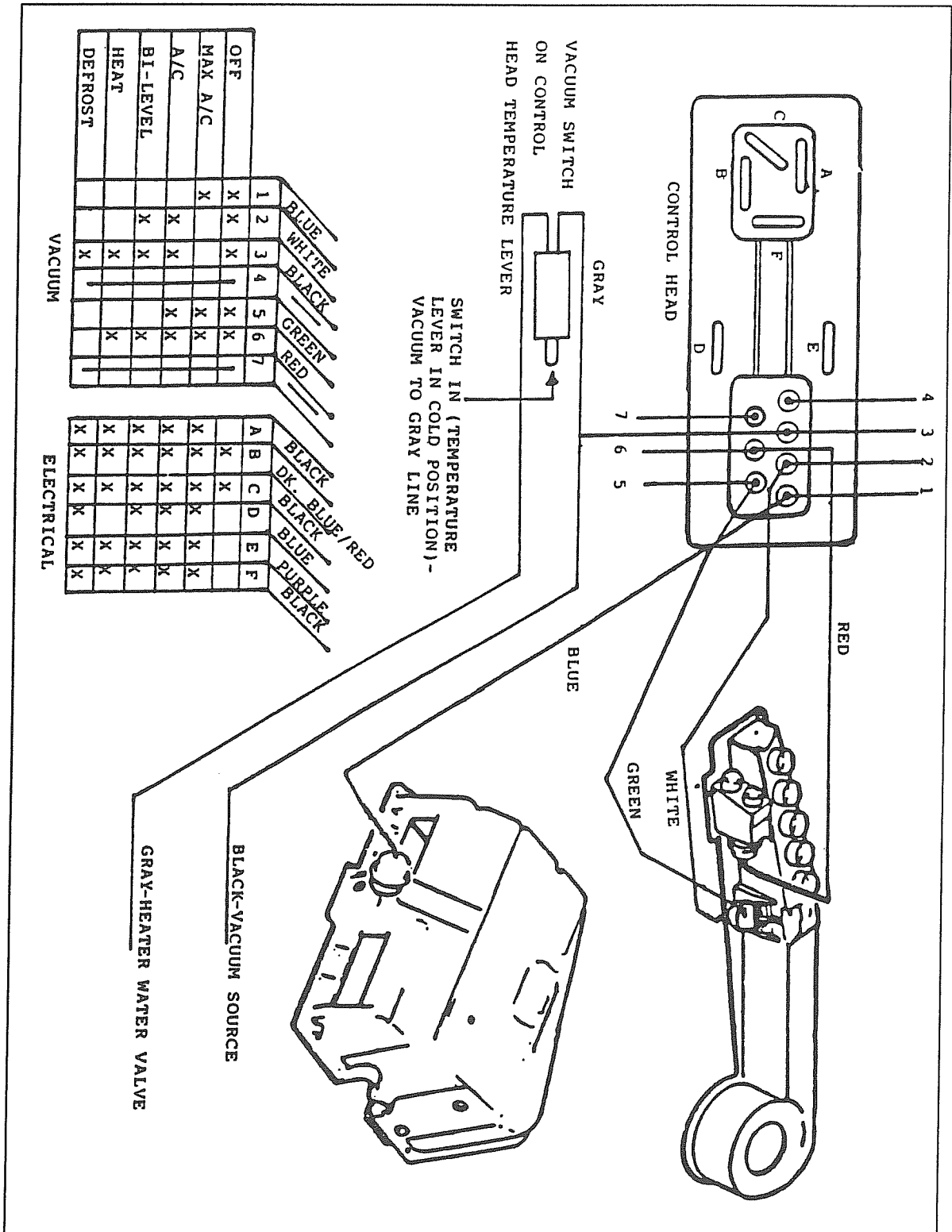

AUXILIARY HEATER

The auxiliary heater, located under the dinette, is plumbed into the radiator system. Two “tees” are located between the engine and the front heater. The water lines to the heater are routed under the floor. By using the two speed dash fan, along with the water valve, the temperature output can be varied.

WATER HEATER

Your motorhome uses a water heater that may have a motor aide feature. This feature circulates radiator cooling through an exchanger in the water heater as you drive. It is plumbed from the same hoses that supply hot water to the auxiliary heater. For further information on your water heater see the Appliance Section of this manual. The water heater with motor aide has caused some complaints. It seems that once you take your motorhome out for a long drive you can't light the burner of the water heater . . . because the water is already hot!

FUEL SYSTEM - CHEVROLET

The fuel system is all standard Chevrolet parts supplied with the motorhome chassis. An electric fuel pump is located on the fuel pick-up tube within the fuel tank. You'll hear this pump run for just a few seconds when the ignition key is turned on. The Chevrolet relay operating the pump would be mounted on the frame work to the left of the engine just below the accelerator.

It should also be noted the Chevrolet fuel system has in in-line filter located along the main frame rail just forward of the step area. The Chevrolet part # is 25055347 or Delco GF 509.

TIRES

The tires installed on your Airstream motorhome are engineered to provide a proper balance of performance characteristics for normal vehicle operation.

This section contains some tips on how you can obtain the most benefit from these tires. Your Chevrolet drivers manual also contains important information on tires and should be reviewed.

Incorrect tire inflation pressures can have adverse effects on tire life and vehicle performance. Too low an air pressure causes increased tire flexing and heat build-up. This weakens the tire and increases the chance of damage or failure and can result in tire overloading, abnormal tire wear, adverse vehicle handling, and reduced fuel mileage. Too high an air pressure can result in abnormal wear and harsh ride, and also increase the chance of damage from road hazards.

Tire inflation pressures should be checked at least monthly and when significantly changing the load you plan to carry in your motorhome. Always check tire inflation pressures when the tires are “cold”.

Standard inflation pressures for tires are listed in the "Minimum Tire Inflation Pressure at Gross Vehicle Weight Rating" chart. Front and rear pressures are shown for each model and GVWR, are based on the GVWR and front and rear axle ratings (GAWRs) printed on your vehicle VIN plate and Certification label. Tires must be inflated to these pressures when the vehicle is fully loaded or an axle GAWR is reached.

MINIMUM TIRE INFLATION PRESSURE (PSI)

Model		Tire Size	Front	Rear Duals
30 ft.	16,500 GVWR	225/70 x 19.5	65 psi	65 psi
33 ft.	16,500 GVWR	225/70 x 19.5	65 psi	65 psi

The outer tire of a pair in dual wheel installations generally wears faster than the inner tire. When vehicles are driven continuously on high crown roads, an increase in air pressure of from 5 psi to 10 psi on the outside tire of each dual produces maximum tire life.

Proper FRONT END ALIGNMENT improves tire tread mileage. Your front end suspension parts should be inspected periodically and aligned when needed. Improper alignment may not cause the vehicle to vibrate. However, improper toe alignment will cause front tires to roll at an angle which will result in faster tire wear. Incorrect caster or camber alignment will cause your front tires to wear unevenly and can cause the vehicle to "pull" to the left or right. The Chevrolet front air bags are inflated to 70 psi when the motorhome is originally aligned. If this pressure varies excessively alignment will be affected.

NOTE: Chevrolet urges each owner to have alignment checked after they have loaded the motorhome as they would on a trip.

WHEEL COVER

The new wheel covers on our motorhomes are removed by pulling off two of the lug nut covers. The two (of ten) loose ones are identified by indentations on three sides to hold them on the nut, and there are no flanges. You will have to look close the first time to find them. Once the nut covers are pulled off, the lug nut extension holding the wheelcover in place is easily removed.

TIRE CHANGING

When removing steel wheel rim to change a tire, loosen all wheel nuts approximately flush with end of stud, then tap clamp ring to loosen rim. Do not remove nuts until clamp rings are free or clamp ring may fly off of stud. When installing rim be sure pins on clamp ring face outboard. Then tighten attaching nuts alternately and evenly to avoid excessive wheel run-out. See torque values and sequence diagram.

LUG NUT TIGHTENING SEQUENCE

WHEEL NUT TORQUE MUST BE CHECKED AT 100, 1,000 AND 6,000 MILES, AND EVERY 6,000 MILES THEREAFTER.

To change front tires the jack should be placed under the control arm. Rear tires, both on dual and tag axles, may be changed by placing the jack under the dual wheeled axle close to the tires being changed.

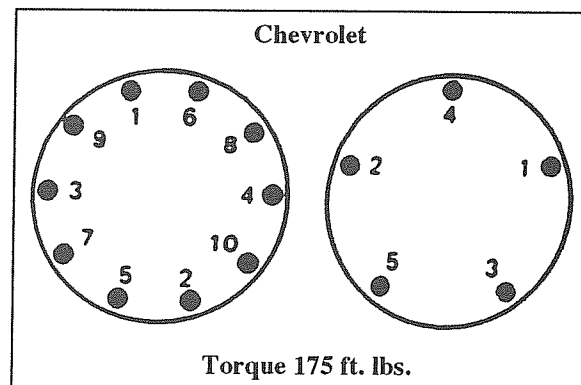

TIRE ROTATION

Front and rear tires perform different jobs and can wear differently depending on the types of rads driven, your driving habits, etc. To obtain the longest tire live you should **INSPECT AND ROTATE** your tires regularly. (See Tire Rotation Illustration).

Radial	First 6,000 Miles and at Least Every 12,000 Miles thereafter.
--------	---

Many GM dealers and tire dealers will perform a free tire inspection to look for uneven or abnormal tire wear.

For the longest tire life, any time irregular wear is seen have the tires checked and rotated by your truck or tire dealer and have the cause of uneven wear corrected. After rotation be sure to check wheel nut tightness and to adjust the tire pressures, front and rear.

WARNING: Wheel nuts should be tightened at certain intervals. See Wheel Nut Tightening Sequence.

There are two different tire rotations we recommend on the 30 and 33 foot models. Rotation A and B, as illustrated on the following page, are to be used with steel wheels. (Rotation A should be done at approximately 6,000 miles and Rotation B at 12,000 miles.)

Your local tire dealer, upon inspection of your tires, may have a tire rotation recommendation that better fits your driving habits and the characteristics peculiar to your vehicle.

Note: It is recommended that disc brake pads be inspected for wear whenever tires are rotated.

TIRE ROTATIONS

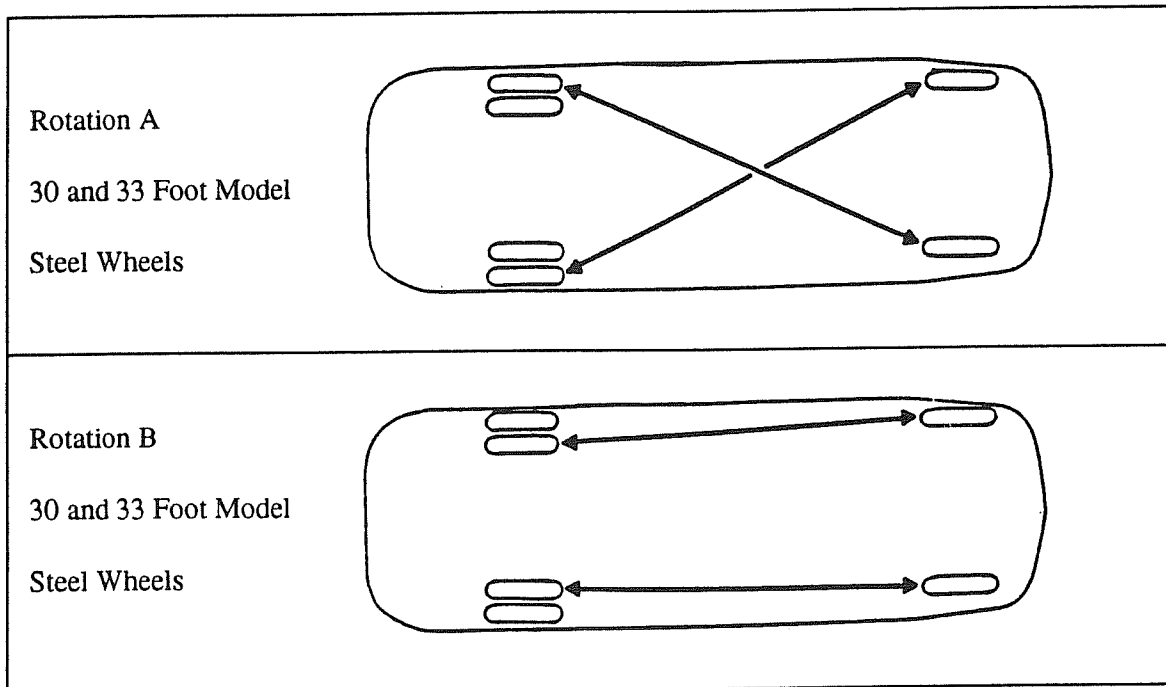

TIRE SUPPORT

Since motorhomes may sit for long periods of time it is important to properly support the tires if blocks are used for leveling.

The following information is provided by the Michelin Technical Group.

Extreme caution must be taken to ensure that the tires are fully supported when using blocks to level motorhomes and/or RV's. The load on the tire should be evenly distributed on the block and in the case of duals, evenly distributed on blocks for both tires. If not properly done, the steel cables in the sidewall of the tires may be damaged and could lead to premature fatigue of the sidewall.

The **CORRECT** methods are shown in Figure 1. Please note that the blocks are wider than the tread and longer than the tire's footprint. This provides maximum support to the tires and assures that the load is evenly distributed throughout the tire's footprint area.

FIGURE 1
CORRECT

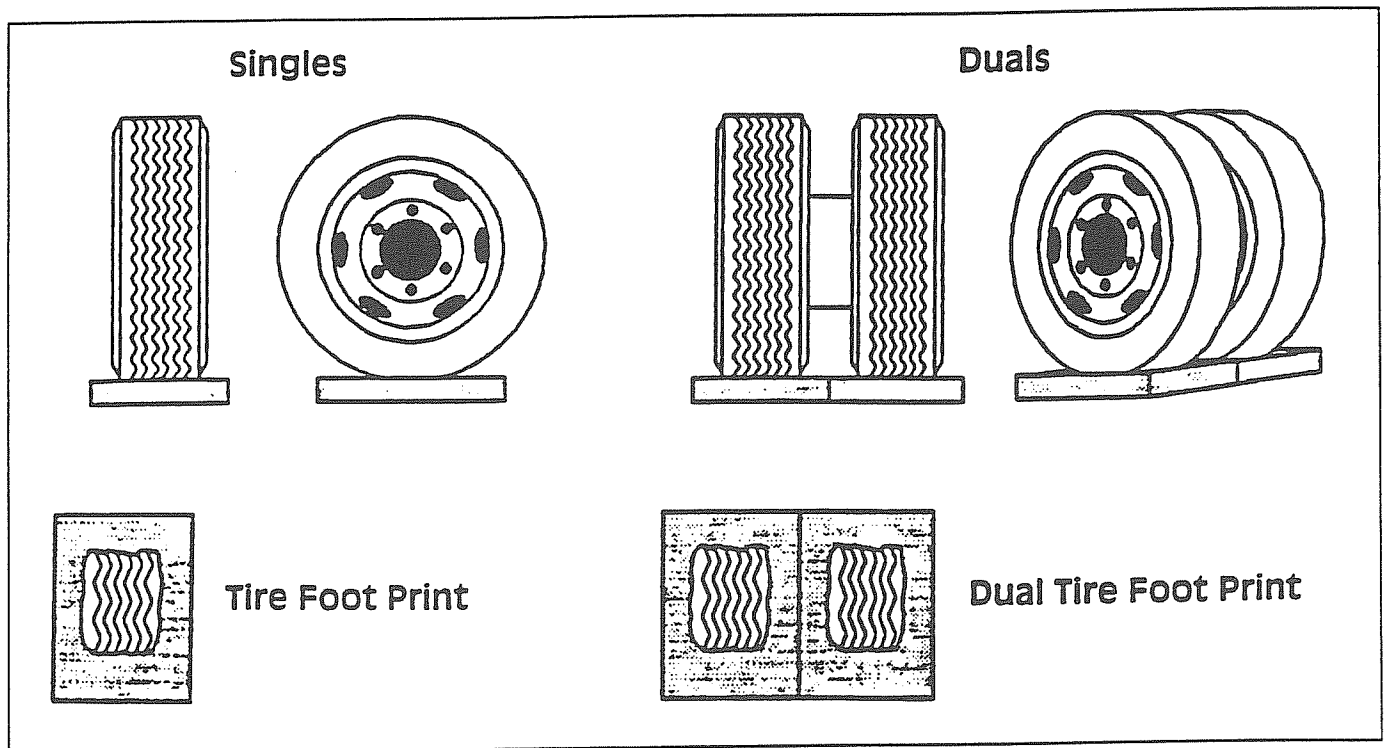

INCORRECT

One tire or a portion of one tire is supporting the full load.

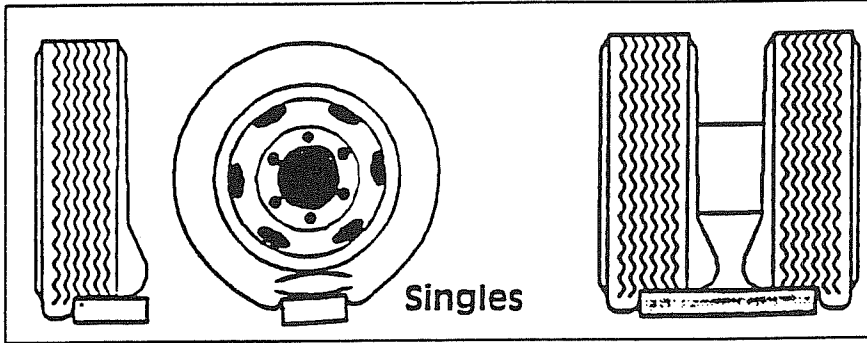
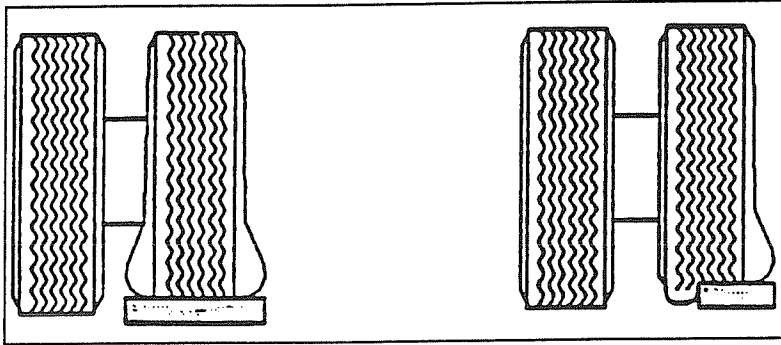

Portion of the two tires supporting the full load.

Tires incorrectly supported, as shown above, may be damaged which could lead to casing failure resulting in serious injury or property damage. If, on previous occasions, the tires have been incorrectly supported, a hidden damage may be present. Please contact your local Michelin dealer and request an inspection and a determination of possible damage.

ELECTRIC STEP (KWIKEE STEP 1 SERIES 28)

Manufacturer: Kwikkee Products Company
Division of Ashton Corporation
P.O. Box 638
Drain, Oregon 97435
Phone: 503-836-2126

The step is easy and convenient to operate. Just inside the main door is a wall switch for the step. When traveling leave the switch in the "ON" position - the step will lower when the door is opened and retract when the door is closed.

When parked, open the door so the step is lowered, Then shut the switch off. The step will remain in the lowered position and the "step" light on the dash will be extinguished. If left on it will run your engine battery down in about a week.

If you forget and leave the switch off as you leave - No Problem! When the ignition is "ON" the wall switch is by-passed and the step will retract when the door is closed.

WARNING: If the wall switch is turned off, and the step is in the retracted position when the ignition is turned off, the step will not lower when the door is opened. Keep your passengers informed.

ELECTRICAL SCHEMATIC

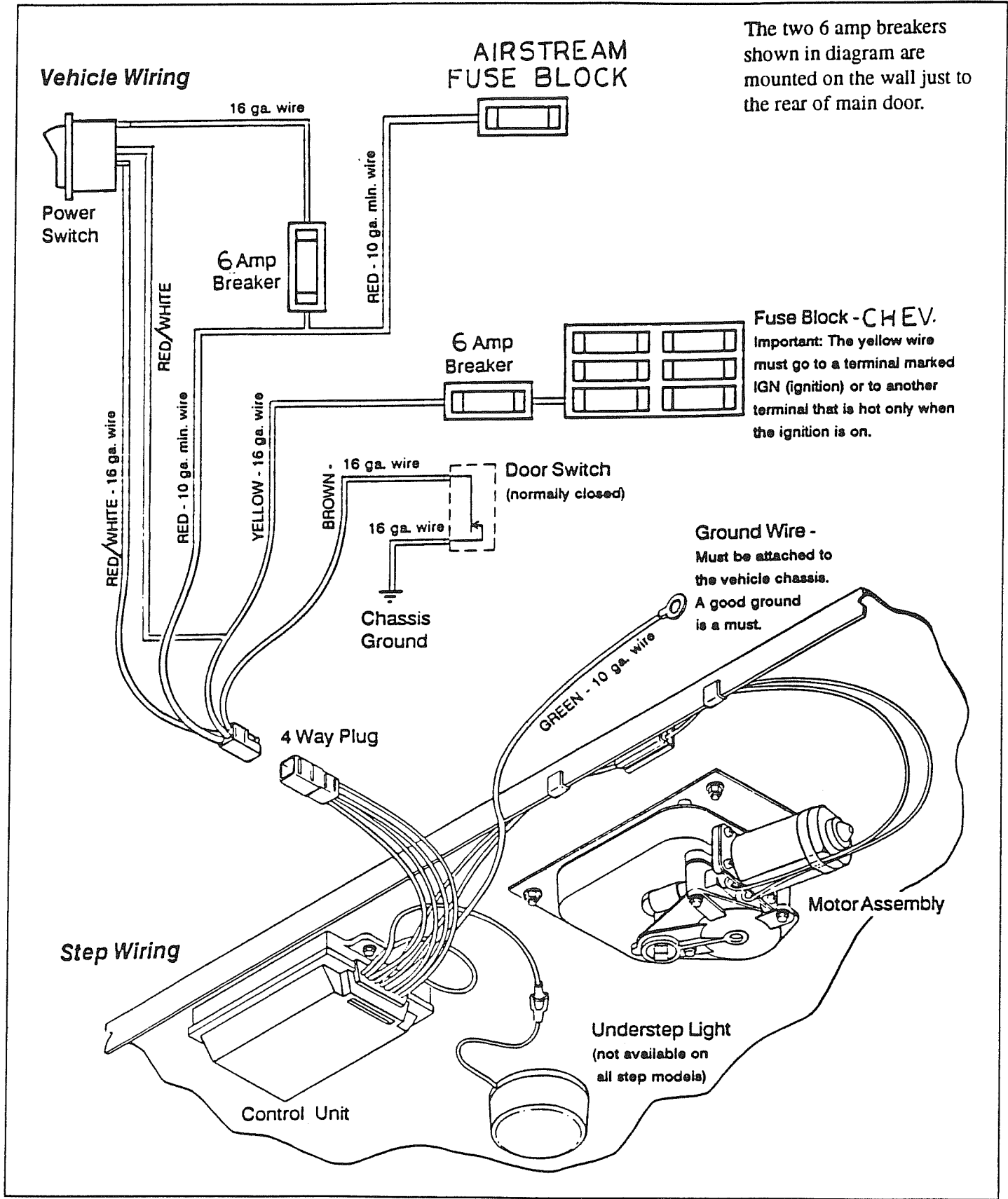

OPERATING INSTRUCTIONS

For control units #9514 and #9591

1. After the installation is complete and with the entrance door open, turn the power switch on.
2. Close the door. The step should retract and lock in the up position.
3. Open the door. The step should extend and lock in the down position with the understep light on. **NOTE** - *The under step light is not available on all step models.*
4. Turn the power switch off. The step should remain in the extended position with the understep light off when the door is closed. The procedure can also hold the step in the retracted position.
5. With the power switch off, the step extended, and the entrance door closed, turn on the vehicle ignition. The ignition safety system will go into effect and the step will automatically retract.

NOTE - *If the yellow wire was not connected in Step #11 of the HOOKUP PROCEDURE the ignition safety system is inoperative and the step will remain in the extended position. If the vehicle is driven with the step in the extended position there is the possibility of causing major damage to both the step and the vehicle. The power switch must be turned on for the step to retract.*

WARNING: *When the ignition safety system goes into effect and the step automatically retracts, DO NOT OPEN THE DOOR until the step completely retracts. If the door is opened before the step completely retracts and locks in the up position, the step will stop moving. The step may only be partially extended. Stepping on a partially extended step may cause damage to the step frame and/or motor assembly. When the door is closed the step will finish retracting.*

WARNING: *If the entrance door is opened before the vehicle ignition is turned off, the step will extend as soon as the ignition is turned off, even if the power switch is off. If the step is not allowed to extend fully and lock out before the door is closed, the step will stop moving. The step may only be partially extended. Stepping on a partially extended step may cause damage to the step frame and/or motor assembly. If the door remains closed, the step will retract if either the ignition or power switch are turned on. If the door is reopened the power switch must be turned on for the step to finish extending.*

WARNING: *If your step does not have the "last out" feature, it will not extend once the ignition has been turned off and the door is opened. The power switch must be turned on in order to operate the step. To determine if your unit has the "last out" feature follow these procedures: With the ignition switch on, the door closed, the power switch off, and the step retracted, turn off the ignition. Open the door. If the step extends, your unit is equipped with the "last out" feature.*

Be Safe - Look Before You Leap!

General Service Notes

If the power wire to the step is disconnected from its source and reconnected, a spark is common. This is caused by the momentary charging of the control unit and does not necessarily indicate the system is staying on, causing a drain on the battery.

If battery drain is suspected, observe the understep light (if so equipped) while the step is extending. The power switch must be on for the understep light to operate. When the step locks into the down position, the understep light should become noticeably brighter. If it does not, the control may not be shutting off. Turn the power switch off and unplug the four way plug between the control unit and the vehicle to prevent overheating the motor.

To further determine that the control is not shutting off, remove the two (2) screws from the connector on the motor leads between the motor and control unit. Remove the seal assembly. (See Figure 2 on page #8) Place a voltmeter between the red and yellow motor leads than reconnect the four way plug. Turn the power switch on. If any voltage is read, the control is not shutting off and may be defective. When doing this test, switch the voltmeter leads back and forth between the red and yellow motor leads to be sure no voltage shows. If any voltage shows, disconnect the four way plug to keep the motor from overheating. If zero voltage is present, the control has shut off and is normal.

If the step does not work or operates erratically, such as extending part way and shutting off, the first item that should be checked is the vehicle battery. The voltage across the battery terminals should be at least 12.7 volts DC to insure a well charged battery. A battery that reads below 12.7 volts DC may drop as low as 8 volts DC when a load is drawn, such as the engaging of the step motor. The control unit will shut off if the loaded voltage falls below 9 volts DC. The control unit will remember which function it was performing. It will wait between two and five seconds (time depends upon temperature) and will try again to complete the original function. If the supply voltage is still below 9 volts, the control will go into another delay state. If the supply voltage remains above 9 volts DC, the original function will be completed. Should the supply voltage again fall below 9 volts the system will go into another delay state. It may take a couple of minutes to complete the original function. Low supply voltage may cause erratic operation of the step. Intermittent ground may also cause erratic operation of the step.

The step may also operate erratically if the step is being operated directly from a converter and the output from the converter is not adequate or properly filtered for clean DC voltage. The converter must be capable of producing a minimum of 30 amps for proper step operation.

If the control unit is hooked up electrically backwards, the step will not operate. If ground to the control unit is lost, either between the step control unit and the vehicle chassis (the 31" long 10 ga. green ground wire), or between the vehicle battery and ground (negative battery cable) the step will not function.

Make sure the battery terminals and all wire connections are clean and tight.

Be sure all wires are of proper gauges or heavier as specified in the wiring diagram.

WARNING: IMPORTANT: No other devices (hearers, fans, burglar alarms, lights, etc.) can be incorporated in the same circuit as the control unit or step. This may cause the step or control unit to malfunction and may void the warranty.

Check the step for physical damage. If the step has been struck by some kind of road hazard, the step mechanism may be bent, causing the step to bind. Check the tread, sliding rails, and extending arms for physical damage. Also check the pivot points for rusting. (See the LUBRICATION AND MAINTENANCE SCHEDULE).

If the power switch is on and the step will not extend when the door is opened and/or retract when the door is closed, but there is a clicking noise coming from the control unit (the engaging and disengaging of the relays in the control unit) the first item that should be checked is the

motor. See the MOTOR TEST PROCEDURE. The relays will engage and disengage (the clicking noise) when the door switch is cycled if the motor is malfunctioning.

These general service notes and the following test procedures cover the most common problems associated with Kwikiee electric steps. Due to the number of variable conditions available, you may experience symptoms other than those covered. Please feel free to contact the customer service department at 1-800-736-9961 for further information or assistance.

TEST PROCEDURE - VEHICLE WIRING

Read the General Service Notes before starting any test procedure.

1. Unplug the four way plug between the control unit and the vehicle wiring. (See Figure 2)
2. **TO CHECK THE MAIN POWER**

SOURCE: Connect a voltmeter between the RED wire from the vehicle half of the four way plug and the ring terminal on the end of the 10 ga. green ground wire from the control unit to the vehicle chassis (See Figure 3). *NOTE - Steps manufactured before August 26, 1991 used a braided ground cable to ground the step to the vehicle chassis. The control unit on steps manufactured after that date are grounded directly to the vehicle chassis by the 10 ga. green ground wire as shown in Figure 2. If the step is equipped with a braided ground cable, substitute the braided ground cable in place of the green ground wire in these test procedures.* The reading should be about 12 volts DC. If the voltage is low there may be a loose or corroded connection, or low battery charge. If the voltage reading is zero, check the 25 or 30 amp fuse/circuit breaker and all connections. Be sure there is a good ground connection between the step frame and the vehicle chassis. SEE Step #2 of the HOOKUP PROCEDURE. A good ground connection is a must. If the reading is approximately 12 volts DC proceed with the next test.

3. **TO CHECK THE POWER SWITCH:**

Connect the voltmeter between the WHITE wire from the vehicle half of the four way plug and the ring terminal on the green ground wire (See Figure 4) The reading should be about 12 volts DC with the power switch on and zero when the switch is off. If the voltmeter reads zero with the power switch on, the first item to check is the inline fuse or circuit breaker in the wire between the power switch and the power lead (red wire). If the fuse/circuit breaker is all right, connect the voltmeter between the terminal on the power switch with the wire leading to the power

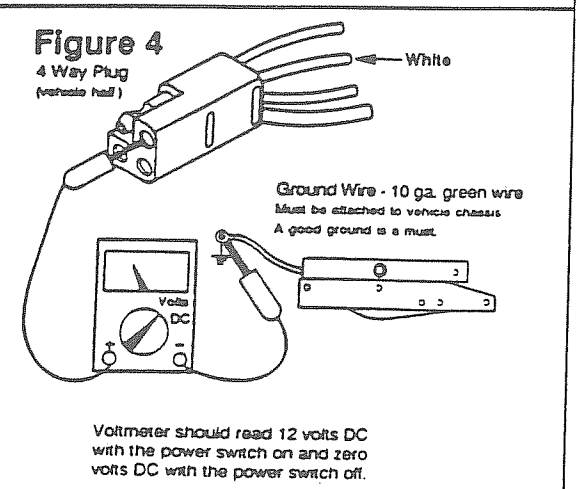
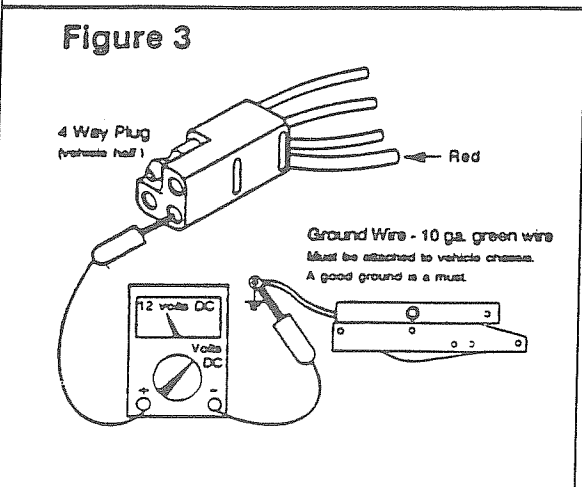
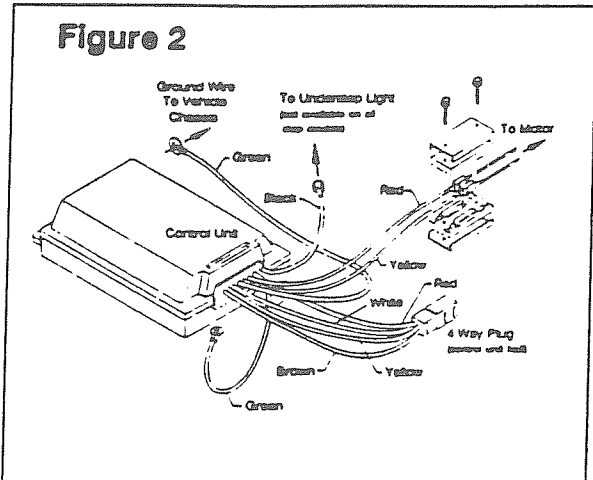

wire (red wire) and ground (See Figure 5). If the reading is still zero check the wire leading to the power lead for a loose connection or cut wire. If the reading is about 12 volts DC, turn on the power switch and check the other power switch terminal in the same manner, by connecting the voltmeter between the terminal and ground. If the reading is zero, replace the power switch. If the reading was about 12 volts DC, there may be a loose connection or cut wire between the power switch and the vehicle half of the four way plug.

4. TO CHECK THE DOOR SWITCH:

Connect the voltmeter between the RED wire from the vehicle half of the four way plug and the BROWN wire in the same plug (See Figure 6). The reading should be about 12 volts DC when the door is open and zero when the door is closed. If the reading is zero with the door open, check the ground connection from the door switch. This connection should be clean and tight. See Step #8 of the HOOKUP PROCEDURE. An improper ground can cause intermittent or erratic operation of the step. If the step will not retract after being extended or extends with the door closed, the BROWN wire to the door switch may be touching a grounded surface inside the wall behind the door jamb, or the door switch terminals may be touching a grounded surface or each other. If the step extends and retracts by itself while traveling, check the conditions previously described. With plunger door switches, be sure that the door switch plunger is depressed at least two thirds of its travel when the door is closed. If the switch is not depressed at least two thirds of its travel, it is possible for the switch to make intermittent contact as the vehicle frame shifts slightly while traveling along the roadway. With magnetic door switches, be sure the magnet is in place and proper clearance is maintained between the switch and magnet. If all the previous conditions check okay, the door switch may be faulty.

5. TO CHECK THE IGNITION SAFETY SYSTEM:

Connect the voltmeter between the YELLOW wire from the vehicle half of the four way plug and the ring terminal on the green ground wire (See Figure 7). The reading should be about 12 volts DC when

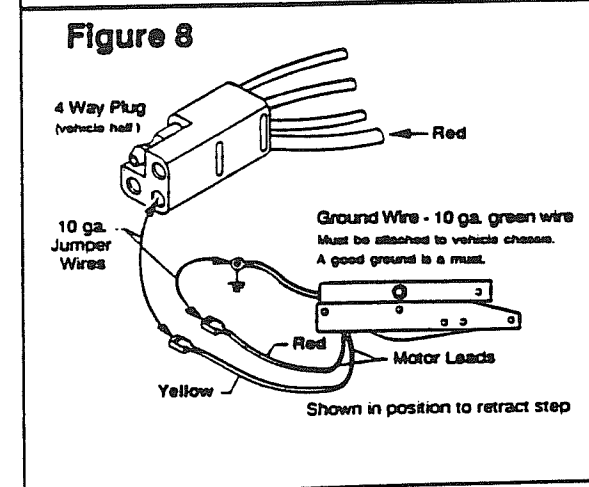
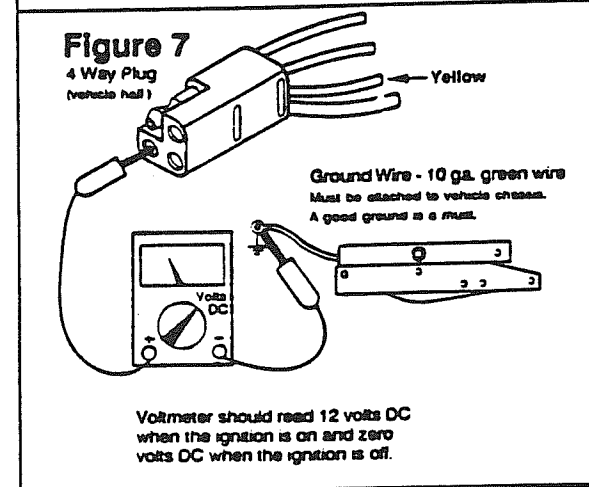
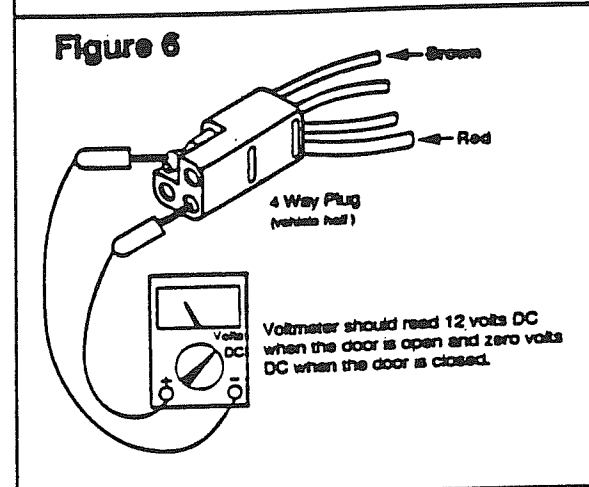
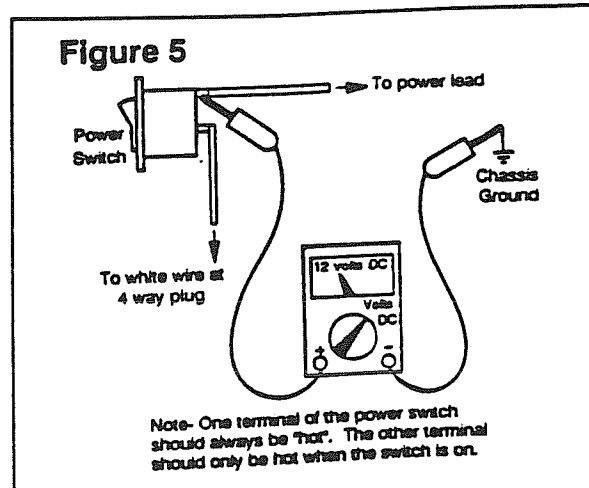

the ignition is on and zero when the ignition is off. If the reading is zero when the ignition is on, check the connection of the yellow wire at the vehicle's fuse panel. If connected at a fuse, check for a blown fuse. **NOTE - On some installations there may be an inline fuse or circuit breaker in the YELLOW wire that should be checked. Kwikkee Products Company, Inc. recommends that this fuse/circuit breaker be installed at this time if the Yellow wire is not already fused.** If the reading was about 12 volts DC when the ignition was off, the YELLOW wire is connected to a constant live source. ON control units #9513 and #9590, if the YELLOW wire is connected to a constant live source, the step will always activate with the door movement, even if the power switch and ignition are off.

NOTE - On some travel trailer and fifth wheel applications, the ignition safety system may not be connected and the voltmeter reading will be zero between the YELLOW wire and the ground wire.

TEST PROCEDURE - MOTOR TEST

6. When checking the motor, remove the two (2) screws from the connector on the motor leads between the motor and control unit. Separate the seal assembly exposing the connectors on the red and yellow motor wires. **CAUTION: Make note of how the wires and connectors are assembled for reassembly later. The wire connectors may be assembled wrong even though the colors match.** Disconnect the motor leads

WARNING: Under no conditions should power be applied to the motor leads while the motor is still connected to the control unit or damage to the control unit will result - voiding the warranty. Connect a 10 gauge jumper wire to the RED wire in the vehicle half of the four way plug. This wire must have power. See Step #2 of the VEHICLE WIRING TEST PROCEDURE: Connect another 10 gauge wire to the ring terminal on the end of the 31" long 10 ga. green ground wire (See Figure 8).

TO RETRACT STEP: Connect the ground jumper wire (jumper from the green ground wire) to the RED motor lead. Touch the power jumper wire (jumper from four way plug) to the YELLOW motor lead.

TO EXTEND STEP: Connect the ground jumper wire (jumper from the green ground wire) to the YELLOW motor lead. Touch the power jumper wire (jumper from four way plug) to the RED motor lead.

CAUTION: Do not leave the jumper wire connected to the motor terminal for more time than it takes to extend or retract the step or damage to the motor may result.

If the motor fails to move, the motor may be defective. If the step has been struck by some kind of road hazard, the step mechanism may be bent and causing the step to bind. The control unit would then shut off power to the step [as described in the BASIC SUMMARY OF OPERATION. Check for physical damage to the tread, sliding rails, extending arms, etc. Also check all pivot pints for rusting. (See the LUBRICATION AND MAINTENANCE SCHEDULE).

If the step doesn't move when power is applied to the motor terminals, but a dim spark is noticeable, there may be damage to the windings inside the motor, requiring replacement of the motor. A dim spark may also indicate a shorted or burned out motor requiring replacement.

If the motor is defective, refer to page #10 and #11 for instructions for removing the motor from the motor assembly.

TEST PROCEDURE - CONTROL UNIT TEST

7. The motor must be operational to test the control unit using this procedure. See MOTOR TEST PROCEDURE.

- a. Ground the negative (-) post of a well charged 12 volt DC battery to the ring terminal on the end of the 31" long 10 ga. green ground wire.

NOTE : A well charged battery will read at least 12.7 volts DC when a voltmeter is connected between the battery posts.

- b. The motor leads must be connected to the control unit.
- c. The four way plug between the control unit and the vehicle should be disconnected. Install pigtail (four way plug - vehicle half - Part #9336 - same plug as supplied with the step for connection to the vehicle) into the control unit half of the four way plug.
- d. Touch the RED and WHITE wires of the pigtail to the positive (+) post of the battery. At the same time, touching the BROWN wire to ground (10 ga. green wire) will cause the step to extend. **CAUTION: Keep hands clear of the step mechanism.**
- e. When the BROWN wire is removed from the green ground wire the step should retract.
- f. Extend the step again by applying power to the RED and WHITE wires and grounding the BROWN wire to the green ground wire. Remove the RED and WHITE wires from the battery before removing the BROWN wire from ground. THIS will cause the step to remain in the extended position.
- g. To test the ignition safety system circuit, apply power to both the RED and YELLOW wires of the four wire pigtail and the step should retract.
- h. On control units #9513 and #9590: To test the "last out feature", remove the YELLOW wire from the battery without removing the RED wire. Ground the BROWN wire to the green ground wire and the step should extend. If the RED wire is removed from the battery before grounding the BROWN wire, Step #7f and #7g must be repeated before testing the last out feature. This test will only work if performed immediately after the ignition safety system test.
- i. If the control unit tests okay, then recheck all wire and ground connections. If the source of the trouble cannot be found, feel free to contact the customer service department for further information or assistance.
- j. If the above tests do not check out, the control unit may be defective and should be returned to the factory for evaluation.

In most cases the control unit does not fail and problems can be traced to vehicle wiring or voltage problems.

Instructions for removing the motor assembly (part #9501) from the step frame and disassembly:

Read all instructions before starting any procedure.

Refer to the motor assembly exploded view drawing on the opposite page for the item numbers referred to in these instructions.

1. Unplug the control unit from the vehicle (four way plug). Do not cut any wiring.
2. Remove the two (2) screws (Item #12) from the connector (Item #18 and #19) on the motor leads between the motor and the control unit. Remove the seal assembly (Item #20). **CAUTION: Make note of how the wires and connectors are assembled for reassembly later. The wire connectors may be assembled wrong even though the colors match** (See Figure 2 on page #C-52)
3. It is easiest to remove the motor assembly from the step frame if the step tread(s) are in a partially extended position. Try to extend the step by following the procedure outlined in Step #6 under the TEST PROCEDURE - MOTOR TEST. If the step is locked in the up position and will not move, read Steps #4 and #5 below before proceeding.
4. Remove the hair pin (Item #6) from the clevis pin (Item #7).
5. Remove the clevis pin (Item #7) from the cast block in the end of the linkage assembly (Item #8, #9 or #10). Note which direction the clevis pin goes into the cast block. If the step is in its locked position, the clevis pin may have to be pried or driven out of the block. If the step is in the locked position, loosening the motor assembly mounting bolts may allow the clevis pin to be removed easier. The step tread(s) should swing freely when the clevis pin is removed. If the tread does not move freely, check for a bent step frame and for rusting at the pivot points.
6. MOTOR REMOVAL - The motor (Item #5 or #5A) may be removed without removing the gear box or linkage assembly simply by removing the three (3) screws (Item #4) along with the bearing bracket (Item #2).
7. GEAR BOX REMOVAL- Unbolt the gear box mounting plate (Item #16) from the step frame.
8. Remove the bearing (Item #3) and the linkage assembly (Item #8, #9, or #10) from the gear case (Item #11) along with the adapter gear (Item #1) and shaft (Item #17).
9. Turn the gear box assembly over and remove the four (4) 1-1/4" long #10 self tapping screws (Item #13) from the gear case. Lift off the mounting plate (Item #16).
10. Remove the bearing (Item #3). Lift off the gear case cover (Item #15) and lift out the gear (Item #14). Note which side of the gear goes up.

Reassembly and installation of the motor assembly (part #9501, #9502, #9503, #9504) on the step frame:

Read all instructions before starting any procedure.

Refer to the motor assembly exploded view drawing on the opposite page from the item numbers inferred to in these instructions.

1. **NOTE** - In the following assembly be sure all bearing pockets and surfaces, gear teeth and the gear hub socket that is in the gear case are well lubricated with a good grade of lithium based grease.
2. Install the gear (Item #14) in the gear case (Item #11). Be sure the gear is reinstalled the same way it was removed (With the penny sized depressions down).
3. Place the gear case cover (Item#15) on the gear case. Set the bearing (Item #3) in the center hole of the gear case cover (the flange of the bearing should be up) and align the square hole in the bearing with the square hole of the gear.
4. Place the mounting plate (Item #16) on the gear case cover (the square holes in the mounting plate should be away from the motor) and install and tighten the four (4) 1-1/4" long #10 self tapping screws (Item #13).
5. Turn the motor assembly over and set it on the flat mounting plate. Install the linkage assembly (Item #8, #9, or #10) into the gear case. Be sure the linkage assembly seats all the way into the gear and bearing or the bearing bracket (Item #2) will not set properly. The swivel ball and cast block should face the front of the motor assembly.
6. Place the bearing (Item #3) on the linkage assembly shaft. Place the flange of the bearing down.
7. Lubricate and set the adapter gear (Item #1) and adapter gear shaft (Item #17) in place and mesh with the main gear (Item #14).
8. Replace the motor (Item #5 or #5A) by carefully aligning the motor and adapter gear (Item #1) so they slide together. Align the holes and push the motor into the screw hole alignment pockets in the gear case.
9. Place the bearing bracket (Item #2) on the motor assembly and install and tighten the motor screws (Item #4). These screws must be very secure.
10. Reinstall the motor assembly on the step frame and tighten all mounting bolts.
NOTE - Be sure the motor assembly is positioned the same way the old one was prior to removal.
11. Install the clevis pin (Item #7) through the drive arms attached to the step frame and the cast block in the linkage assembly (Item #8, #9, or #10). Be sure to reinstall the clevis pin in the same direction it was removed. Install the hair pin (Item #6) in the clevis pin.
12. Reassemble the motor to control unit leads. See Step #2 under disassembly.
13. Connect the control unit to the vehicle (four way square plug).
14. Test step functions.

MOTOR ASSEMBLY

Note - Item #9 (part #9565) - identified by a 7/32" dia. hole under the edge of the straight ball drive link.

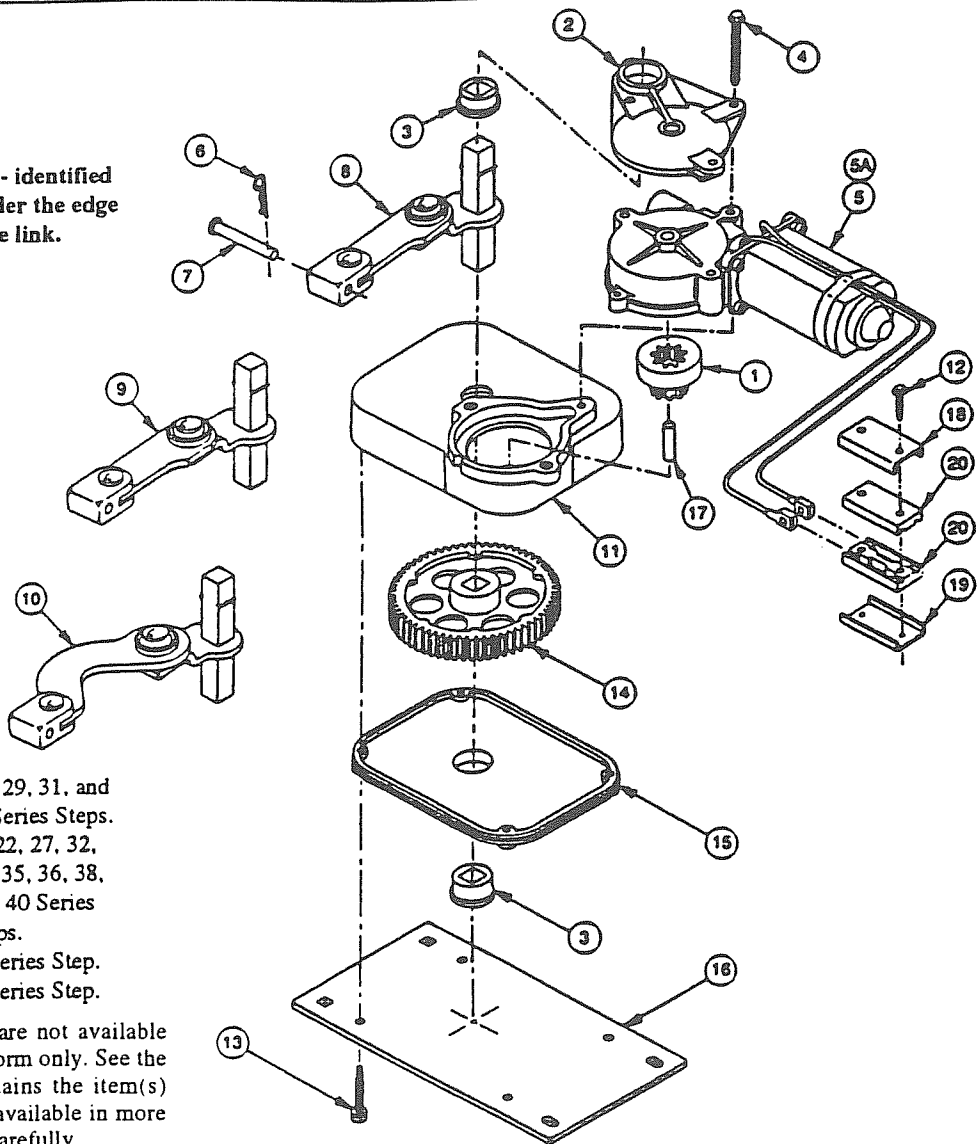

Motor Assembly #9501 - 28, 29, 31, and 39 Series Steps.

Motor Assembly #9502 - 21, 22, 27, 32, 34, 35, 36, 38, and 40 Series Steps.

Motor Assembly #9503 - 23 Series Step.

Motor Assembly #9504 - 26 Series Step.

NOTE - The items listed below are not available individually. They are sold in kit form only. See the PARTS LIST for which kit contains the item(s) needed. The items below may be available in more than one kit, so check the listings carefully.

ITEM NO.	PART NO.	DESCRIPTION	Qty. Per Motor Assembly			
			9501	9502	9503	9504
1	9556	Adapter Gear	1	1	1	1
2	9552	Motor Bearing Bracket	1	1	1	1
3	9045	Bearing	2	2	2	2
4	9560	#10 Self Tapping Hex Washer Head Screw - Type 23 - 1-3/4" Long	3	3	3	3
5	9550	Motor	1	1	-	1
5A	9551	Motor - High Torque (for use with 23 series steps only)	-	-	1	-
6	9018	Hair Pin	1	1	1	1
7	9017	Clevis Pin	1	1	1	1
8	9553	Linkage Assembly for Motor Assembly #9501	1	-	-	-
9	9565	Linkage Assembly for Motor Assembly #9504	-	-	-	1
10	9554	Linkage Assembly for Motor Assembly #9502 and #9503	-	1	1	-
11	9555	Gear Case	1	1	1	1
12	9561	#6 Self Tapping Hex Washer Head Screw - Type 23 - 3/4" Long	2	2	2	2
13	9298	#10 Self Tapping Hex Washer Head Screw - Type 23 - 1-1/4" Long	4	4	4	4
14	9038	Gear	1	1	1	1
15	9037	Gear Case Cover	1	1	1	1
16	7039	Motor Mounting Plate	1	1	1	1
17	9557	Adapter Gear Shaft	1	1	1	1
18	9559	Clamp Plate - Upper	1	1	1	1
19	9562	Clamp Plate - Lower	1	1	1	1
20	9558	Wire Connector Seal	2	2	2	2

LUBRICATION AND MAINTENANCE SCHEDULE

Clean all mud, salt, and road grime from step before lubricating. Lubricate all moving parts (bearings, pivot points, slides, clevis pin, and drive linkage ball) every 30 days with a good quality moisture and heat resistant penetrating grease. Kwik-Lube Spray Grease is specially formulated to lubricate Kwik-ee electric steps and is recommended for lubricating all moving parts. See the Parts List for Kwik-Lube ordering information.

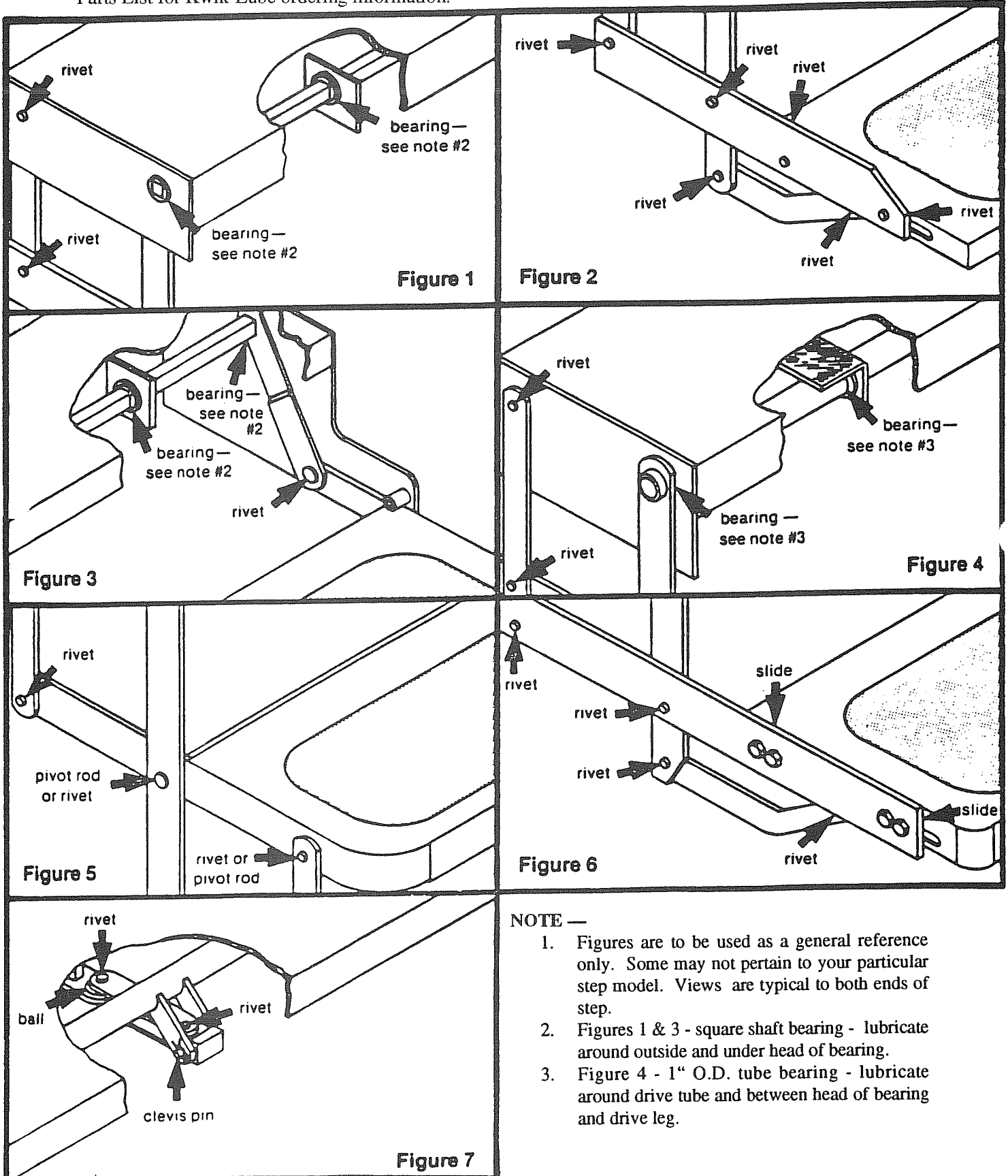

CAMPING

SAFETY

As always, safety should be one of your top priorities. Make sure you, and everyone traveling with you, can operate the main door and exit window rapidly without light.

WARNING: *The roadside rear window is designed as an escape window. To escape, pull in on the two red latches at the bottom. The complete window sash will swing out to allow easy exit. The pleated shade is opened by sliding straight up. The window operation should be checked each trip and explained to all traveling companions.*

WARNING: *At each campsite make sure you have not parked in such a manner as to block the operation of the escape window by being too close to trees, fences or other impediments. Scenic views are one reason for traveling, but don't park so the beautiful lake or steep cliff is just outside your escape window.*

WARNING: *Read the directions carefully on the fire extinguisher. If there is any doubt on the operation, you and your family should practice, then replace or recharge the extinguisher. You will find your local fire department will be happy to assist you and answer any questions.*

WARNING: ***DON'T SMOKE IN BED!**
KEEP MATCHES OUT OF REACH OF SMALL CHILDREN!
DON'T CLEAN WITH FLAMMABLE MATERIAL!
KEEP FLAMMABLE MATERIAL AWAY FROM OPEN FLAME!*

We have all heard these warnings many times, but they are still among the leading causes of fires.

Other safety information on the LPG system of your motorhome is located in the Plumbing Section of this manual.

SMOKE ALARM

OPERATION, TESTING

OPERATION: The smoke detector is operating once a fresh battery is installed and testing is complete. When products of combustion are sensed, the unit sounds a loud 85 db pulsating alarm until the air is cleared.

HUSH CONTROL: The "HUSH" feature has the capability of temporarily desensitizing the alarm circuit for approximately 7 minutes. This feature is to be used only when a known alarm condition, such as smoke from cooking, activates the alarm. The smoke detector is desensitized by pushing the "HUSH" button on the smoke detector cover. If the smoke is not too dense, the alarm will silence immediately and "Chirp" every 30-40 seconds for approximately 7 minutes. This indicates that the alarm is in a temporarily desensitized condition. The smoke alarm will automatically reset after approximately 7 minutes and sound the alarm if particles of combustion are still present. The "HUSH" feature can be used repeatedly until the air has been cleared of the condition causing the alarm.

NOTE: DENSE SMOKE WILL OVERRIDE THE HUSH CONTROL FEATURE AND SOUND A CONTINUOUS ALARM.

CAUTION: BEFORE USING THE ALARM HUSH FEATURE, IDENTIFY THE SOURCE OF THE SMOKE AND BE CERTAIN A SAFE CONDITION EXISTS.

FLASHING L.E.D. LIGHT: This smoke detector is equipped with a flashing red indicator light. The light is located under the test button and will flash every 30-40 seconds to indicate that the smoke detector is receiving power.

TESTING: Test by pushing the test button on the cover and holding it down for a minimum of 2 seconds. This will sound the alarm if all the electronic circuitry, horn and battery are working. If no alarm sounds the unit has defective batteries or other failure. You can also test the alarm by blowing smoke into it.

TEST THE ALARM WEEKLY TO ENSURE PROPER OPERATION. Erratic or low sound coming from your alarm may indicate a defective detector, and it should be returned for service.

FALSE ALARMS

Smoke detectors are designed to minimize false alarms. Cigarette smoke will not normally set off the alarm, unless the smoke is blown directly into the detector. Combustion particles from cooking may set off the alarm if the detector is located close to the cooking area. Large quantities of combustible particles are generated from spills or when broiling. Using the fan on a range hood which vents to the outside (non recirculating type) will also help remove these combustible products from the kitchen.

MODEL 0916 HAS A "HUSH" CONTROL that is extremely useful in a kitchen area or other areas prone to nuisance alarms. For more information refer to **OPERATION AND TESTING**.

If the detector does alarm, check for fires first. If a fire is discovered, get out and call the fire department. If no fire is present check to see if other reasons may have caused the alarm.

MAINTENANCE

BATTERY REPLACEMENT

To replace the battery remove the detector from the mounting plate by rotating the detector in the direction of the "OFF" arrow on the cover.

The Model 0916 Smoke Detector uses one (1) 9 volt battery. The **SMOKE DETECTOR** is powered by a 9V carbon zinc battery (**alkaline** battery may also be used). A fresh battery should last for one year under normal operating condition. This detector has a low battery monitor circuit which will cause the detector to "chirp" approximately every 30-40 seconds for a minimum of seven (7) days when the battery gets low. Replace the battery when this condition occurs. ***USE ONLY THE FOLLOWING 9 VOLT BATTERIES FOR SMOKE DETECTOR REPLACEMENT.***

Carbon-zinc type:	EVEREADY 216 OR 1222 GOLD PEAK 1604P OR 1604S
Alkaline type:	EVEREADY 522; DURACELL MN1604; Gold Peak 1604A
Lithium type:	ULTRALIFE U9VL.

NOTE: REGULAR TESTING IS RECOMMENDED.

WARNING!! USE ONLY THE BATTERIES SPECIFIED. USE OF DIFFERENT BATTERIES MAY HAVE A DETRIMENTAL EFFECT ON THE SMOKE DETECTOR.

NOTE: IF AFTER BATTERY REPLACEMENT, THE UNIT CONTINUES TO CHIRP, WAIT FOR APPROXIMATELY 7 MINUTES. THE "HUSH" FEATURE MAY HAVE BEEN ACTIVATED ACCIDENTALLY WHILE CHANGING THE BATTERIES AND WILL RESET AUTOMATICALLY.

CLEANING YOUR DETECTOR:

To clean your detector remove it from the mounting bracket as outlined in the beginning of this section.

You can clean the interior of your detector (sensing chamber) by using your vacuum cleaner hose and vacuuming through the openings around the perimeter of the detector.

The outside of the detector can be wiped with a damp cloth.

AFTER CLEANING, REINSTALL YOUR DETECTOR. TEST YOUR DETECTOR BY USING THE TEST BUTTON.

LIMITATIONS OF SMOKE ALARMS:

WARNING!! Smoke detectors are devices that can provide early warning of possible fires at a reasonable cost; however, detectors have sensing limitations. Ionization type detectors offer a broad range of fire sensing capability but are better at detecting fast flaming fires than slow smoldering fires. Photoelectric detectors sense smoldering fires better than flaming fires. Home fires develop in different ways and are often unpredictable. Neither type of detector (photoelectric or ionization) is always best, and a given detector may not always provide warning of a fire. Also, smoke detectors do have limitations. For a battery powered detector the battery must be of the specified type, in good condition, and installed properly. AC powered detectors will not operate if AC power has been cut off such as by an electrical fire or an open fuse. Smoke detectors must be tested regularly to make sure the batteries and the detector circuits are in good operating condition.

Smoke detectors cannot provide an alarm if smoke does not reach the detector. Therefore, smoke detectors may not sense fires starting in chimneys, walls, on roofs, on the other side of a closed door or on a different floor. If the detector is located outside the bedroom or on a different floor, it may not wake up a sound sleeper. The use of alcohol or drugs may also impair ones ability to hear the smoke alarm. For maximum protection a smoke detector should be installed in each sleeping area on every level of a home.

Although smoke detectors can help save lives by providing an early warning of a fire, they are not a substitute for an insurance policy. Home owners and renters should have adequate insurance to protect their lives and property.

GOOD SAFETY HABITS

DEVELOP AND PRACTICE A PLAN OF ESCAPE:

- Make a floor plan indicating all doors and windows and at least two (2) escape routes from each room. Second story windows may need a rope or chain ladder.
- Have a family meeting and discuss your escape plan, showing everyone what to do in case of fire.
- Determine a place outside your home where you all can meet if a fire occurs.
- Familiarize everyone with the sound of the Smoke Alarm and train them to leave your home when they hear it.
- Practice a fire drill at least every six months. Practice allows you to test your plan before an emergency, you may not be able to reach your children. *It is important they know what to do.*

WHAT TO DO WHEN THE ALARM SOUNDS:

- Leave immediately by your escape plan. Every second counts, so don't waste time getting dressed or picking up valuables.
- In leaving, don't open any inside door without first feeling its surface. If hot, or if you see smoke seeping through cracks, *don't open that door!* Instead use your alternate exit. If the inside of the door is cool, place your shoulder against it, open it slightly and be ready to slam it shut if heat and smoke rush in.
- Stay close to the floor if the air is smokey. Breathe shallowly through a cloth, wet if possible.
- Once outside go to your selected meeting place and make sure everyone is there.
- Call the fire department from your neighbors home — *not from yours!*
- Don't return to your home until the fire officials say that it is all right to do so.

There are situations where a smoke detector may not be effective to protect against fire as stated in the NFPA standards 72.

For instance:

- a) smoking in bed;
- b) leaving children home alone;
- c) cleaning with flammable liquids, such as gasoline.

Further information on fire safety can be obtained in a pamphlet titled "IN A FIRE SECONDS COUNT" published by the NFPA, Batterymarch Park, Quincy, Mass. 02269.

SERVICE AND WARRANTY

If after reviewing this manual you feel that your smoke alarm is defective in any way, do not tamper with the unit. Return it for servicing to: FYRNETICS, INC., 1055 STEVENSON CT./STE 102W, ROSELLE, IL 60172. (See Warranty for in-warranty returns).

CARBON MONOXIDE ALARM

OPERATING INSTRUCTIONS

TEST PROCEDURE: These test procedures should be carried out regularly to insure proper operation of the detector at all times. Failure to do so may result in the detector not alarming in the presence of CO.

WARNING

Test detector operation after vehicle has been in storage, before each trip, and at least once per week during use.

Important: Read through these steps before performing the test

Any time the unit has been disconnected and then reconnected to power, there will be an audible "chirp" of the alarm and the LED will blink green for approximately four minutes. During this time the unit is running a check of all components except the LED and the audible alarm. To check the LED and audible alarm —

- Press the TEST button. You will hear the loud and piercing alarm and observe the LED is blinking red.
- Press the TEST button and hold it in until the alarm stops sounding.

If you do not hear the alarm or see the LED blinking red return the unit to your nearest service center.

STORAGE

When the RV is not to be used for long periods of time, the detector should be disconnected from power. Otherwise, over the course of three to five months, it could drain the battery (similar to clocks and other electric devices).

CLEANING

To clean, use mild soap and water. **DO NOT** use cleaning fluids which contain volatile organic compounds such as alcohols or propane. Cleaning spaces should be well ventilated when cleaning supplies or similar contaminants are used.

WARNING

Do not forget to reconnect power when putting your RV back into use or the detector will not detect the presence of carbon monoxide (CO) which can be fatal.

CO DETECTION

As long as the detector does not measure a concentration of CO greater than 100 ppm there will be no visual or audible indication and the unit will simply indicate that it is working by displaying a steady green light at the LED.

PREALARM INDICATION OF CO

Whenever the measured concentration of CO exceeds 100 ppm the detector will provide a visual indication of the amount present in the air by alternating the steady green light of the LED with a blinking red color a number of times every 8 seconds (See Table below).

Note: The exact amount of ppm present in the air as measured by the detector will vary somewhat depending upon the temperature of the ambient air and the humidity.

The following table summarizes the visual indications of the LED for levels of carbon monoxide gas being detected at the sensor.

PPM*Level	Max. Time to alarm	Red Flashes	Frequency
0-100	90 Minutes	None	N/A (steady green)
100-200	35 Minutes	1	every 8 seconds
200-400	15Minutes	2	every 8 seconds
400-800	Less than 15 Minutes	4	every 8 seconds
>800	Less than 10 Minutes	8	every 8 seconds

*Parts Per Million

Under these pre-alarm conditions, *if no one is exhibiting the effects of carbon monoxide poisoning (headache, dizziness, nausea, etc.), you should take the following actions:*

- Immediately get fresh air into premises or vehicle
- Call a qualified technician to inspect the logical sources for carbon monoxide and adjust, repair, or replace as needed.

The detector takes into account the amount of time that a certain concentration of CO is present before giving an indication. Therefore it may take an equal amount of time for the detector to go back to the steady green state.

If the measured CO concentration persists beyond safe limits defined by the UL Standards, the detector will go into alarm conditions.

ALARM CONDITIONS

As the concentration of CO present persists, the exposure will approach the alarm condition.

WARNING

Actuation of this device indicates the presence of carbon monoxide (CO) which can be FATAL.

IF THE ALARM SOUNDS, FOLLOW THESE STEPS:

1. If anyone has a headache or an upset stomach, call the Fire Department and immediately move to a location which has fresh air. DO A HEAD COUNT TO CHECK THAT ALL PERSONS ARE ACCOUNTED FOR. DO NOT REENTER PREMISES UNTIL IT HAS BEEN AIRED OUT AND THE PROBLEM CORRECTED! If no one exhibits symptoms of discomfort associated with CO poisoning, simply;
2. Operate reset button,
3. Turn off all appliances, vehicle, or other sources of combustion at once (furnace, water heater, wood (coal, kerosene) burning stove or heater, RV, automobile, or the like).

IF WARNING SIGNAL IS ACTIVATED,

4. Immediately get fresh air into the premises or vehicle.
5. Call a qualified technician and have the problem fixed before restarting appliances or vehicle.

LP GAS DETECTOR

In the kitchen area of your unit, approximately six inches above the floor, is the LP gas detector. LP gas is a mixture of gases produced and sold commercially as a fuel for heating and cooking appliances. LP gas is highly flammable and, as a result, can be explosive if ignited under certain circumstances. LP gas is heavier than air and, if confined in a closed space, will accumulate close to the floor. When the LP gas concentration in your unit exceeds 2000 ppm the detector will provide a visual and audible alarm by sounding a buzzer and flashing the red LED two times per second.

WARNING

Activation of this detector indicates the presence of LP gas which can cause an explosion and/or fire. This normally indicates a leak in the LP gas installation or a LP gas appliance. Extinguish all open flames, open your windows and door and evacuate the unit immediately. Do not activate any electrical switch. Turn off the LP at your gas bottle(s). DO NOT RE-ENTER YOUR UNIT UNTIL THE PROBLEM HAS BEEN CORRECTED BY A QUALIFIED REPAIR TECHNICIAN.

OPERATION

Your LP gas detector is wired directly to your vehicle battery and incorporates a 1 amp. in-line fuse. When the device is operating normally the green LED will be lit.

WARNING

It is not recommended that the detector be disconnected from the battery during periods of storage. There is a small heater on the sensor of the device which "burns" away impurities in the air during periods of normal use. During periods when power is interrupted, impurities can build up on the sensor. When power is returned to the detector the detector alarm may activate until the impurities are "burned" off. This could take a number of hours, during which time the alarm will be constantly "on".

DETECTOR TEST

Press the test button for 5 to 6 seconds until the alarm sounds then release the test button. The red LED should flash and the alarm sound for approximately 4 minutes. This test should be performed at least once a week during normal vehicle operation, and after periods of storage, and before each trip.

LOW VOLTAGE

Below 10 VDC the detector will continue to operate but will blink alternately green and orange. Below 8 VDC the unit will behave erratically and will eventually shut off. To ensure proper operation, do not operate the unit below 10 VDC.

COMPONENT FAILURE

The failure of any circuit component will cause the detector to display a continuous orange LED fault light and a short beep indicating failure. If this occurs, immediately contact your dealer or Airstream Customer Service for the name of the nearest detector service center.

Please read the operating instructions for your detector which have been supplied with the paperwork of your unit.

OVERNIGHT STOP

In time you will develop a knack for spotting wonderful little roadside locations by turning off the main highway and exploring. There are many modern recreational vehicle parks, including State, County and Federal parks with good facilities, where you may obtain hookups of electrical, water and sewer connections. Directories are published which describe in detail these parks and tell what is available in the way of services and hookups.

Overnight or Weekend Trips

On overnight or weekend trips, chances are you will not use up the capacity of the sewage holding tank, deplete the water supply, or run down the batteries which supply the living area 12 volt current.

Longer Trip

On a longer trip, when you have stayed where sewer connections and utility hookups were not available, it will be necessary for you to stop from time to time to dispose of the waste in the holding tank and replenish the water supply. Many gas stations (chain and individually owned) have installed sanitary dumping stations for just this purpose. Booklets are available which list these dumping stations.

When you stop for the night, your Airstream motorhome is built to be safely parked in any spot that is relatively level and where the ground is firm. Your facilities are with you. You are self-contained. Try to pick as level a parking spot as possible.

Hydraulic Leveling Jacks

Some models are equipped with hydraulic leveling jacks that can be deployed. Complete instructions are included with the Owners Packet. Be sure to read the directions completely prior to operating the jacks. The jacks will be able to level your unit in most modern campgrounds. However, their capabilities are limited, and in some situations you will have to use planks to level the coach.

TV Backing Monitor

The optional TV backing monitor can be extremely helpful, especially when traveling alone. The Owners Packet includes complete instructions on use. Practicing with the monitor in a safe place will make it much easier for you to use when it is really needed.

All you need to do to enjoy the self-contained luxury is to:

1. Turn on LP gas supply and light appliance pilots if required.
2. Turn on water pump and open faucets until air is expelled from the system.

Before moving on, turn off the LP gas and water pump, check your campsite, both for cleanliness and also to be sure you haven't left anything behind. Make sure everything is properly stowed.

WINTER TRAVELING

Traveling in your motorhome during the cold winter months can be a most exhilarating experience. There are, of course, certain precautions which must be taken as you would in your home in low temperatures.

WARNING: *Always shut off the LP gas when gasoline is added to the fuel tank.*

Some states do not allow LPG to be turned on while moving. While traveling in these states you must use your common sense. How cold is it? How long will it be before you can turn the heat back on? Is the temperature dropping or rising? Remember, the wind chill factor when driving 50 MPH will cause the interior of the motorhome to cool much faster than when it is parked.

1. You must have a plentiful supply of propane gas.
2. If your stay is longer than overnight, you should endeavor to have 120-volt electricity available. The batteries, fully charged, will not last more than about 15 hours in freezing weather. Of course, you can run your generator to recharge the batteries, or even use the generator continually. Since the generator starts off the same battery as the engine, it is recommended to start the generator prior to shutting off the engine. This will prevent running the engine battery down should there be a difficulty in starting the generator in the cold temperatures.
3. Minimize use of electricity if 120 volt power source is not available.
4. Leave cabinet doors, bed doors and wardrobe doors slightly open at night to allow circulation of air in and around all furniture components.
5. Use propylene glycol type antifreeze in waste and drain water tanks to prevent freezing. Quantity of antifreeze needed will vary with ambient temperature and the amount of liquids in tank.
6. For extended stays in cold weather, insulate the water line outside the motorhome. You should remember that low temperatures in combination with high winds cause an equivalent chill temperature much below what your thermometer is reading. For instance, with an outside temperature of zero degrees, and the wind velocity of 10 miles per hour, the equivalent chill temperature is minus 20° F. The exterior water faucet has an in-line valve inside the motorhome. In below freezing temperatures, shut off the valve inside and open the exterior brass valve so it will drain.

Condensation

It is also important to guard against excessive humidity inside your motorhome during winter campouts. When windows and window frames fog up or "sweat," it means that there is too much moisture in the air. Moisture comes from water vapor and water vapor is the direct result of water evaporating.

Many things such as baths and showers, boiling foods, washing dishes, washing clothes, even breathing, contribute to evaporation. The inside air can only absorb so much of this moisture before it becomes saturated. At this point it can hold no more, and any additional water vapor condenses back to liquid water in the form of droplets on any available cool, solid surface. Temperature has a direct effect on the air's saturation point. Cold air holds less moisture than warm air. For this reason, the air immediately adjacent to cold outside walls and windows cools down and causes water vapor to condense and form moisture droplets, even though warmer inside surfaces are still dry.

The best way to keep condensation under control is to reduce moisture producing activities. It is important to provide adequate ventilation and keep the air circulating as much as possible.

Use your exhaust fans to remove moisture before water vapor mixes with the air. Open windows slightly once in a while, while operating fans, to bring in drier outside air and aid in overall air circulation. In extremely cold weather, when outside ventilation is not practical, it may be necessary to use a small dehumidifier to aid in reducing condensation.

There is no substitute for common sense in cold weather.

Note: The Airstream motorhome is built as a recreational vehicle and is not intended as a permanent dwelling or for more than temporary use in sub-freezing temperatures.

EXTENDED STAY

Making a long trip is not very different from making a weekend excursion. Since everything you need is right at hand, you are at home wherever you go. When packing for an extended trip, take everything you need, but only what you need.

Some models are equipped with Hydraulic Leveling Jacks that can be deployed. Complete instructions are included with the Owners Packet. Be sure to read the directions completely prior to operating the jacks.

When you plan to stay in the same place for several days, weeks or months, you will want your motorhome to be as level as possible. Check the attitude with a small spirit level set on the inside work counter. If a correction is necessary, then you must first level from side to side. This can be done most easily by driving up a small ramp consisting of 2" x 6" boards tapered at both ends. **WE DO NOT RECOMMEND PLACING TIRES IN A HOLE FOR LEVELING.** Check the tire section of the chassis portion of this manual for information on tire support.

Hook Up to Water by attaching a 1/2" minimum high pressure water hose to the city water service, or the hose from the water reel if so equipped.

Plug the Electrical Cable into the City Power Service. Be sure you have the wire grounded and have the proper polarity. See Electrical Section for technical details.

A Cable TV Hookup is located on the roadside rear corner of the motorhome. It is already wired into the existing system, so the exterior connection is all that is required.

To operate the **Generator** simply start the generator at the control panel. After the generator has run a couple of minutes, an automatic relay will close and current from the generator will be supplied to the 120-volt circuit breakers. This is indicated by the AC power light on the control panel starting to glow. Operating the generator for about one hour each day will normally keep the battery charged.

Hook your **Waste Drain Hose into the Sewer Disposal Facility** and attach to the drain outlet in your motorhome. For details on this procedure see Drain and Waste System Section.

Turn on the gas supply and light the oven pilot. Lighting a top range burner to bleed any air from the system will make it easier to start other appliances.

When you stay for extended periods where electric or water hookups are not available, you must make regular checks on the condition of your 12 volt battery and the contents of your water tank. Carry drinking water in a clean bucket to refill your tank. When your waste tank nears capacity, move your motorhome to a dumping location.

EXTERIOR

The side walls and roof of your Airstream Land Yacht motorhome are laminated fiberglass. This means they aren't painted so small mars and scratches can be polished out. We recommend this be done professionally since excessive polishing can remove all the laminate.

There is no magic to caring for your motorhome. As a general rule of thumb, we recommend the motorhome be washed about every four weeks and waxed in the spring and fall. To make sure your new unit is always protected, you should wax it immediately or have your dealer wax it just prior to delivery. In industrial areas cleaning and waxing should be done on a more frequent schedule.

ALWAYS CLEAN YOUR MOTORHOME IN THE SHADE OR ON A CLOUDY DAY WHEN THE SKIN IS COOL. Oil, grease, dust and dirt may be removed by washing with any mild non-abrasive soap or detergent. Cleaning should be followed by a thorough clean water rinse. Spots and streaks may be prevented by drying the unit with a chamois or a soft cloth.

After cleaning and drying, a good grade of non-abrasive automotive paste or liquid wax will increase the life of the finish, especially in coastal areas where the finish is exposed to salt air, or in polluted industrial areas. It will also protect the shell from minor scratches and make subsequent cleaning easier.

It is important to remove sap, gum, resin, asphalt, etc., as soon as possible after they appear by washing and rewaxing. Sunlight and time will bake-harden these materials, making them almost impossible to remove without heavy buffing. If asphalt remains on the motorhome after washing, use a small amount of kerosene on a rag and wipe the spots individually, being careful not to scratch the finish.

It is recommended that the caulking and sealant used in external seams and joints such as window frames, light bezels, beltline and rub-rail molding, etc., be checked regularly. If this material has dried out and becomes cracked or checked, or if a portion has fallen out, it should be replaced with fresh material to prevent possible rain leaks. Caulking and sealing material is available from your Legacy dealer.

Main Door Lock

The door lock on your motorhome operates in the same manner as the locks used on most automobiles. Locking the latch actually disengages the linkage between the handles and the latch. This prevents forced entry by using large pliers on the lock handle.

We urge you to keep an extra set of keys for both the door lock and the ignition hidden somewhere on the exterior of the coach. We probably receive a dozen calls a year from people who have lost keys or locked them in the coach. Your keys will overcome the keyless lock system used on the dead bolt.

Occasionally you might find the latch catch, shown in the open position below, out of time. This simply means it has been bumped and has flipped to the closed position when the door is still open. To re-time, hold the door handle in the open position, then pull out and down on the latch catch. It should flip to the open position as shown in the illustration.

LOCK ASSEMBLY, DRIVERS DOOR

1. Mounting plate,
Door Lock
2. Lock Handle, Inside
3. Latch Catch
4. Keeper, Rod Linkage
5. "E" ring, Tumbler
Installation

(Lock assembly as viewed
from inside of door with
cover plate removed.)

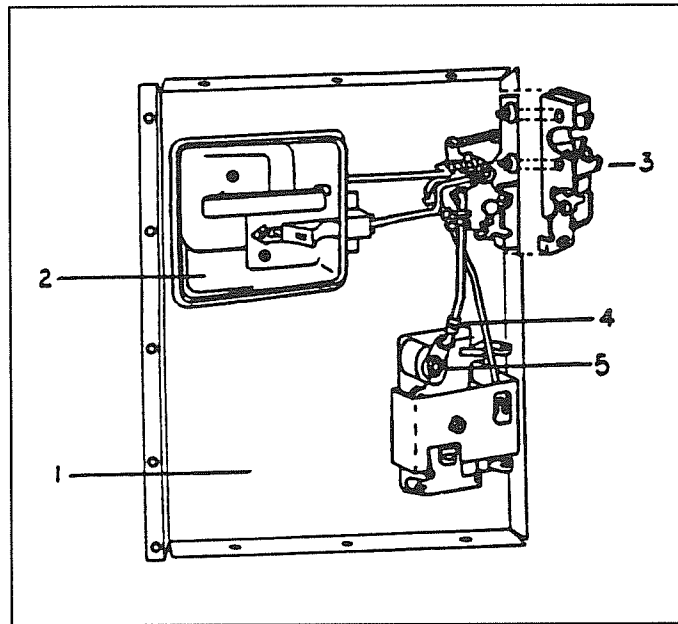

Access to the linkage mechanism of the lock is gained by removing the two screws holding the lock handle and the center panel of the inside door skin. This will expose the door lock assembly, as shown in the illustration.

The tumbler is replaced by removing the inside lock handle and the center panel of the inside door skin so the lock assembly is exposed. Insert key into tumbler then remove the "E" ring (item #5 on Illus), being careful it is not lost.

LOCK ASSEMBLY, MAIN DOOR

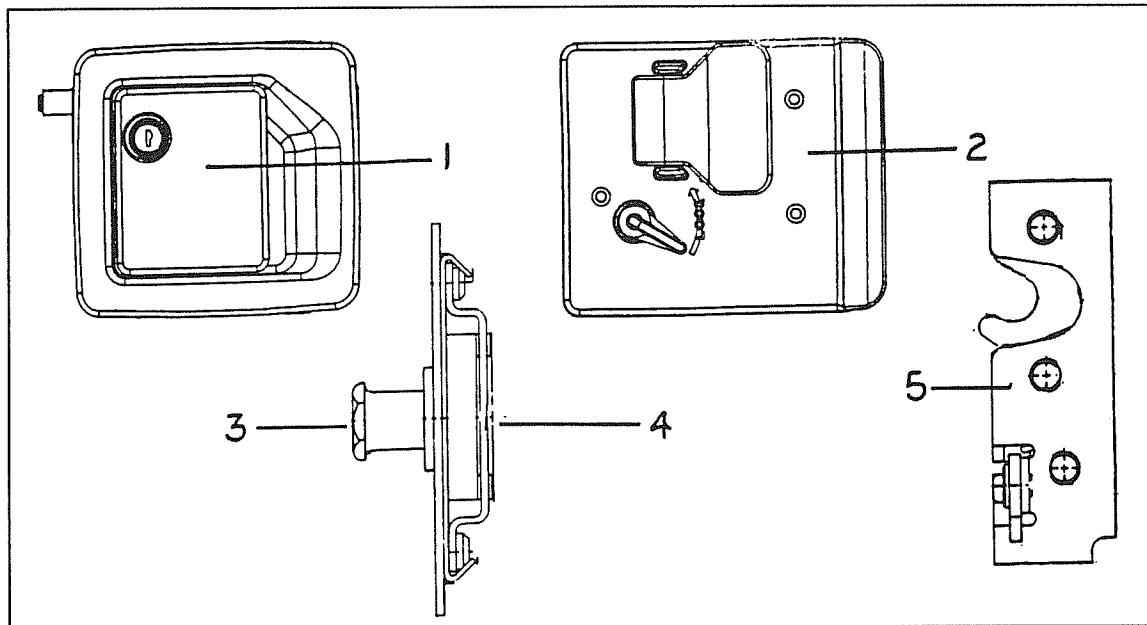

1. Outside housing assembly
2. Inside plate
3. Striker bolt
4. Caged nut
5. Rotary latch

KEYLESS DOOR LOCK

Operation

The dead bolt portion of your motorhome may be controlled by radio signals produced by the key fob shown below. One characteristic of this system is the one second delay after a pad has been depressed.

NOTE: When you use the keypad to turn the patio lights ON you must also use the keypad to turn them OFF. The same goes for the switch inside the door. . . if you turn the lights on with this switch, you must use the same switch to turn them off. You cannot turn the lights on with the keypad and off with the switch.

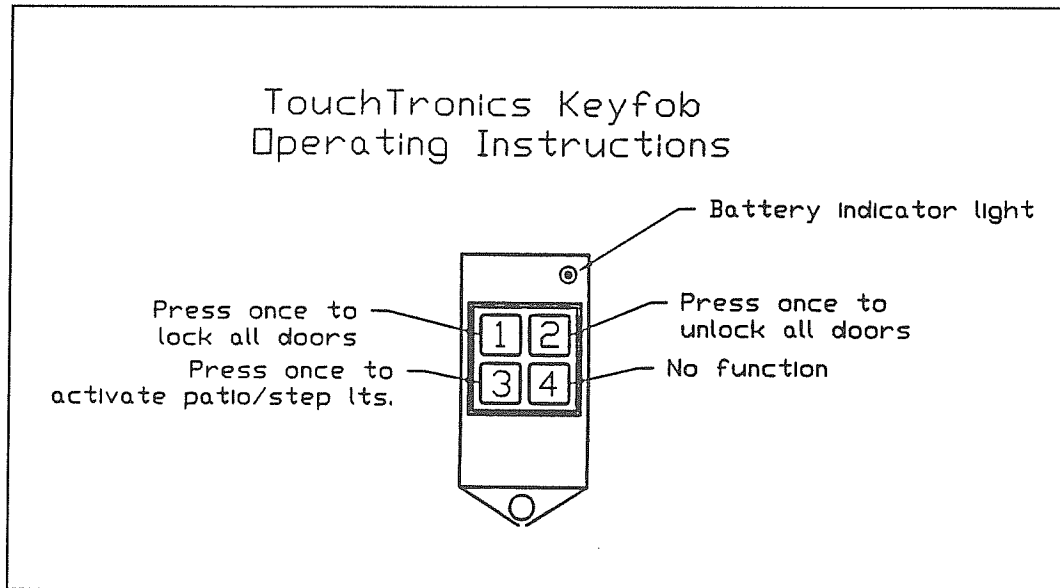

Service

There are four major components operating the door locks; control module/receiver, dash switch, relay, and drive motors. The control module is mounted on the inside wall just behind the main door. The relay operates in conjunction with the dash switch and is located up under the left hand side of the dash. The drive motors, located at each lock, are polarity sensitive. When testing you'll find the wires at the drive motors will switch from positive to negative and vice versus as the key fob or dash switch is being operated. When using the dash switch the relay under the dash performs the polarity switching functions and the control module/receiver serves the same function when the key fob is used.

A detailed wire layout is provided in the electrical section of this manual.

ROOF LADDER

For traveling, the ladder should be hinged down and snapped securely into the nylon sockets. If the ladder is down and rear engine access is required, the bottom of the ladder is pulled out of the sockets (a good hard tug is needed) then swung up vertically. As it nears vertical, the slot in the hinge will fall into a locked position and hold the ladder up. To lower, raising up on the ladder will release the hinge and allow the ladder to be pivoted down to use position.

WARNING: The intent of the ladder is for service access to roof mounted components. Vertical ladders require physical dexterity to climb. Only you can judge your own physical abilities. If in doubt - stay off the ladder!

CAUTION: The maximum roof capacity is 250 lbs. spread over a minimum of 4' x 4' area. This criteria is easily met by the service technician placing appropriately sized paneling or plywood on the roof.



INTERIOR

The luxurious interior of your Airstream motorhome has been designed for comfort, convenience, durability and appearance. An understanding of the operational procedures and maintenance techniques of the interior appointments will add to your pleasures, as well as to the long life of your motorhome.

Lounges

To convert the Deluxe Sofa into a bed, pull straight up and remove armrest, grasp the front edge of the seat, raise and pull it toward the aisle of the motorhome. The back rest will slide down into place automatically.

Cocktail Chairs

The cocktail chairs have two adjustments. One lever will allow the chair to rotate. The other lever lets the chair slide forward and back.

CAUTION: Rotating the chair when it's slid back against the wall can damage the upholstery. Position the chair so it isn't chafing when in transit.

Dinette

The dinette is hinged to the wall and is supported by one folding table leg. To make into a bed, the front of the table is lifted slightly, the release latch is depressed on the leg bracket, and the leg is then folded up against the bottom of the table leaf. Velcro will hold it up in position. Raising the front of the table leaf further allows it to be in position. Raising the front of the table leaf further allows it to be unhooked from the wall. The leaf will then swing out and down onto the support ledges on the front of the dinette seat. The back rests are then laid on the table leaf to complete the bed.

Fabric Cleaning

All material should be professionally dry cleaned to remove any overall soiled condition. These materials may be spot cleaned, however, using the cleanability code instructions as listed. Sample swatches are furnished to our dealers. The dealer will be able to give you the cleaning code and part number for the fabrics used in your particular motorhome.

The following are the cleanability code instructions for the various fabrics used in the Airstream motorhomes:

Cleanability Codes

CODE W-S

Fabric care. Spot clean this fabric either with a mild solvent or a water-based cleaning agent. When using a solvent or dry cleaning product, follow instructions carefully and clean only in a well-ventilated room. Avoid any product which contains highly toxic carbon tetrachloride. You may also use an upholstery shampoo product or the foam from a mild detergent. With either method, pretest a small area before proceeding. Use a professional furniture cleaner when an overall soiled condition is reached.

CODE S

Fabric care. Spot clean, using a mild, water-free solvent or dry-cleaning product. Carefully follow instructions on such product. Clean only in a well-ventilated room. Avoid any product containing carbon tetrachloride, which is highly toxic. Pretest small area before proceeding. Use a professional furniture cleaner when an overall soiled condition is reached.

CODE W

Fabric care. Spot clean, using the foam only from a water-based cleaning agent, such as mild detergent or non-solvent upholstery shampoo product. Apply foam with a soft brush in a circular motion. Vacuum when dry. Pretest small area before proceeding. Use a professional furniture cleaner when an overall soiled condition is reached. The above code was designed by the manufacturer of the fabric.

CAUTION:

Never remove cushion cover for separate cleaning or washing. Any tumble cleaning method can destroy the backing, shrink or otherwise damage upholstery.

SMOKING WARNING

Keep your furniture and family safe from fires caused by careless smoking. Do not smoke when drowsy. Remove immediately any flowing ash or a lighted cigarette which falls on furniture. Smoldering smoking material can cause upholstered furniture fires.

Drapes

Use the following procedures to remove drapery panels for cleaning:

Front Wrap Around Drapes

1. Remove screws securing rear end of drapery track bracket to wall, both roadside and curbside.
2. Slide draperies to the rear until they are clear of track.
3. After reinstalling drapes, replace screws in end of track.

CAUTION: All drapery materials and mattress covers must be professionally dry cleaned.

To prevent excessive wear to drapery linings, blinds must be secured at the bottom and slats turned vertically when driving long distances.

Shades

The shades are operated in the same manner as most venetian blinds. Pulling down on the rope raises the shade. Swinging the rope to one side prior to releasing it will secure the shade in position.

A feather duster, or the soft-bristled brush often found as part of vacuum cleaner attachments, are recommended for cleaning the blinds and pleated shades.

The mini blinds can be spot cleaned with soapy detergent. However, you must be very careful or you may find yourself washing each individual slat so they'll match.

The longevity of the pleated shades in the rear will be increased if the shades are in the up position when your vehicle is stored.

Carpet

The carpet can be cleaned with any good commercial carpet cleaner, or with a detergent and water. **HOWEVER, BE CAREFUL NOT TO SOAK THE CARPET WITH WATER.**

Hardwood Flooring

Daily care for the planked hardwood floor is by vacuuming. Occasionally waxing with a non-water base wax will help extend the life of the floor.

WARNING: Warn occupants of the vehicle when fresh wax has been applied, just like a home, the floor will be slippery.

Counter areas

The counter areas around the sink are of a high-pressure laminate or corian and can be cleaned with soap and water, or you can use a common solvent on tough spots. Be sure no abrasive cleaner is used, as there is the possibility it could scratch the surface. A protective pad should always be placed under hot utensils.

Corian counters can be repaired by sanding minor damaged areas. The color of the material is constant and not just a surface coat.

Walls/cabinets

The vinyl walls of the motorhome can be wiped with any mild household cleaner. The wood grain panel also has a vinyl covering for easy care. The cabinet doors and framework are hardwood, so any good furniture polish can be used.

CAUTION: Do not use any abrasive material on the vinyl covered walls.

Bathroom

The counter areas around the lavatory sink are of a high-pressure laminate or corian and can be cleaned with soap and water, or you can use a common solvent on tough spots. Be sure no abrasive cleaner is used, as there is the possibility it could scratch the surface.

Corian counters can be repaired by sanding minor damaged areas. The color of the material is constant and not just a surface coat.

Shower Stall

To clean your ULTRA/GLAS shower stall unit, use warm water and one of the stronger liquid detergents. Do not use abrasive cleaners; they may scratch and dull the surface of your ULTRA/GLAS unit. Stubborn stains can be removed with solvents such as turpentine, paint thinner or acetone. Restore dulled areas by rubbing with an automotive-type liquid cleaner, then put the soft glow back into your ULTRA/GLAS unit with a light application of liquid wax.

PLUMBING

LPG SYSTEM

Your motorhome is equipped with a permanently mounted tank for LPG (Liquid Petroleum Gas). LPG burns with a clean blue flame. There are two basic types of LPG in common usage: Butane and Propane. Butane is widely used where temperatures are normally above freezing the year round, and Propane is used where subfreezing temperatures are common, since Butane freezes at 32°F as compared to -40°F for Propane. **ALL OF THE ORIFICES IN THE LPG APPLIANCES ARE OF THE UNIVERSAL TYPE WHICH WILL BURN EITHER FUEL.** How long a full tank of gas will last is dependent on usage. In cold weather, when you are using the furnace, large amounts of hot water, and cooking extensively, you will naturally use more than you will in warm weather, when you may do limited cooking. On the average, with normal cooking and other appliance use, you can probably count on one month of usage from the tank.

If you have allowed the tank to run out, air may have gotten into the lines. In this event the air must be forced out through the lines by gas pressure before you can light the pilots. Hold a match to the pilot of the appliance closest to the tanks until it lights and stays lit. Then move to the next closest, etc.

WARNING:

All pilot lights and appliances must be turned off during refueling of motorhome fuel tank and permanently mounted LPG tank. Gas lines should be checked periodically for leaks with ammonia free soapy water. Do not use open flame.

CAUTION:

Moisture in the LPG tank will cause a malfunction of the regulator in controlling proper pressure. This may result in the flame lifting off the burner, or the flame may go out frequently. Many refueling stations will add approximately 1/4 to 1/2 gallon of alcohol to lower the moisture temperature. Moisture will then pass through the regulator without the formation of ice crystals.

WARNING:

If gas can be smelled, appliance pilots fail to stay on, or any other abnormal situation occurs, shut off tank valve immediately and call on a qualified LPG service center or Airstream Service Center.

LPG Regulator

The LPG regulators used on Airstream motorhomes are designed for low pressure service, with a normal outlet pressure setting of 11.5 water column. Only personnel trained in the proper procedures, codes, standards, etc., should service regulators.

Have the regulator inspected each time the tank is refilled. Make sure the regulator vent opening on both first and second stage regulators does not become plugged by mud, insects, snow, ice, paint, etc. Vents must remain open.

Replace any regulator that has had water in the spring case, or shows evidence of external corrosion, or corrosion inside the spring case. Closely examine regulators directly connected to the container valve by means of a solid POL adapter (horizontal mounting) for signs of corrosion. (An Airstream Service Center is recommended for this service.)

BASIC RULES FOR SAFETY

WARNING: DO NOT store LP containers within vehicle. LP containers are equipped with safety devices that vent gas should the pressure become excessive.

WARNING: DO NOT use cooking appliances for comfort heating. Cooking appliances need fresh air for safe operation. Before operation open overhead vent or turn on exhaust fan and open window.

A warning label has been located in the cooking area to remind you to provide an adequate supply of fresh air for combustion. Unlike homes, the amount of oxygen supply is limited due to the size of the recreational vehicle, and proper ventilation when using the cooking appliances will avoid dangers of asphyxiation. It is especially important that cooking appliances not be used for comfort heating as the danger of asphyxiation is greater when the appliance is used for long periods of time.

WARNING:

Portable fuel burning equipment, including wood and charcoal grills and stoves, shall not be used inside the recreational vehicle. The use of this equipment inside the recreational vehicle may cause fires or asphyxiation.

WARNING:

A Warning Label has been located near the LP gas container. This label reads: DO NOT FILL CONTAINER(S) TO MORE THAN 80% PERCENT OF CAPACITY. Overfilling the LP gas container can result in uncontrolled gas flow which can cause fire or explosion. A properly filled container will contain approximately 80 percent of its volume as liquid LP gas.

WARNING:

Do not bring or store LP gas containers, gasoline or other flammable liquids inside the vehicle because a fire or explosion may result.

WARNING:

If you smell gas:

- 1. Extinguish any open flames, pilot lights and all smoking materials.**
- 2. Do not touch electrical switches.**
- 3. Shut off the gas supply at the tank valve(s) or gas supply connection.**
- 4. Open doors and other ventilating openings.**
- 5. Leave the area until odor clears.**
- 6. Have the gas system checked and leakage source corrected before using again.**

WARNING:

LP gas regulators must always be installed with the diaphragm vent facing downward. Regulators that are not in compartments have been equipped with a protective cover. Make sure that regulator vent faces downward and that cover is kept in place to minimize vent blockage which could result in excessive gas pressure causing fire or explosion.

LP TANK INSTALLATION

The regulator at the L.P. tank is under a black plastic cover. The protective cover certainly helps to keep the vent on the regulator from getting clogged by wasps or ice, but should still be checked regularly to make sure the vent remains clear.

WARNING: Do not attempt to seal regulator cover.

WARNING:
Check vent each time tank is filled to make sure it is clear of obstructions.

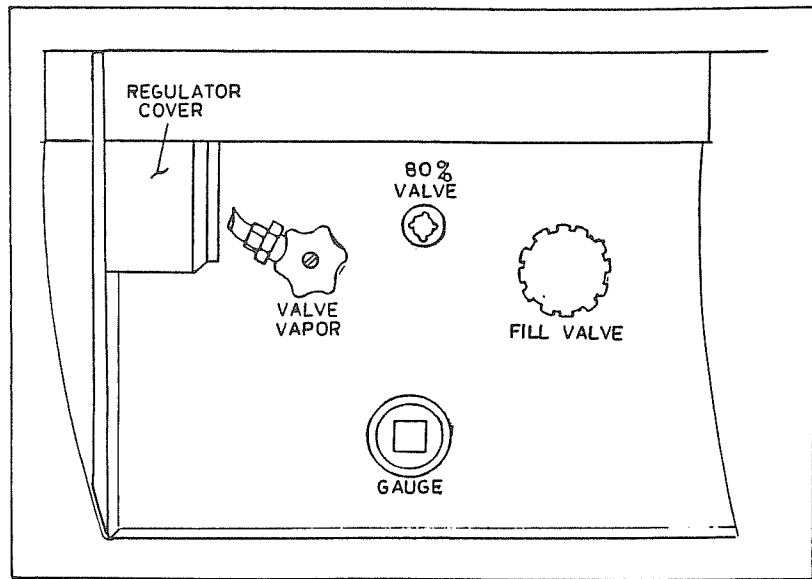

Gas Regulator Removal/Replacement

1. Shut off main gas supply at the tank.
2. Remove the plastic protective cover from the regulator assembly.
3. Using two wrenches, one to hold the line fitting and one to turn the flare nut, disconnect the regulator from the flexible rubber line.
4. Disconnect the regulator from the tank fitting. Remove regulator.
5. To replace, reverse the removal procedures.

TYPICAL LP GAS SYSTEM

- A. RANGE TOP - MAGIC CHEF 85RB-3BT
17,500 BTU, AGA/CGA, P/N 640398
- B. WTR HTR - ATWOOD 6GH-6E
8,800 BTU, AGA/CGA, P/N 690225
- C. REFRIG - DOMETIC RM 3804
1,500 BTU, AGA/CGA, P/N 690317-01
- D. FURNACE - HYDROFLAME 8535 35,000
BTU, AGA/CGA, P/N 690274

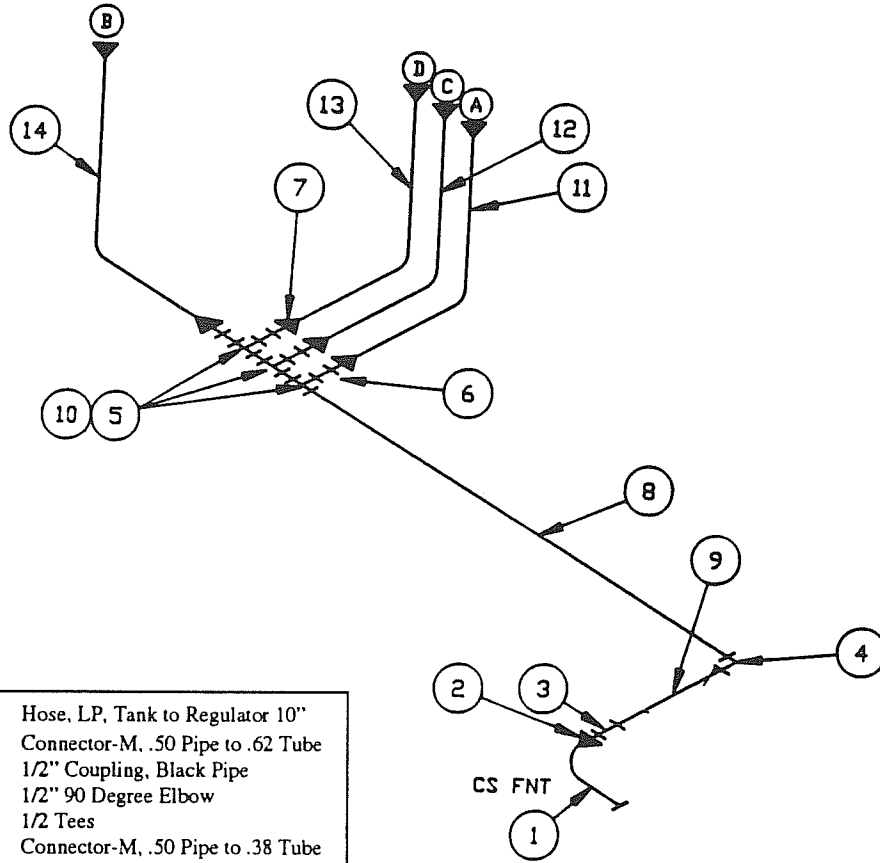

1	601335	Hose, LP, Tank to Regulator 10"
2	601412-12	Connector-M, .50 Pipe to .62 Tube
3	601410	1/2" Coupling, Black Pipe
4	601408	1/2" 90 Degree Elbow
5	601409	1/2 Tees
6	601412-08	Connector-M, .50 Pipe to .38 Tube
7	600435	Forged Flare Nuts 3/8"
8	601407-22	1/2" Sch. #40 Bl. Pipe 93.25" Lg
9	601407-23	1/2" Sch. #40 Bl. Pipe 23.00" Lg
10	601407-01	1/2" Sch. #40 Bl. Pipe 2.00" Lg
11	600008	Tubing Copper 3/8OD
12	600008	Tubing Copper 3/8OD
13	600008	Tubing Copper 3/8OD
14	600008	Tubing Copper 3/8OD

WATER SYSTEM - SELF CONTAINED

Fill the water tank by opening the exterior door marked water fill, remove screw cap and pull the vent plug. A garden hose can now be inserted. It's a good idea to let the water run through the hose for a short time to flush it out. Experienced Rvers usually fill their tanks with "home" water to avoid strange water that may be distasteful to them.

The amount of water in the tank may be checked on the Monitor Panel, or you may fill the tank until water overflows out of the fill.

Turn water heater by-pass valves to normal flow position. The by-pass valves are located in the lavatory cabinet. Open the cabinet door and pull out the vertical panel for access.

For normal operation open valves A and C and close valve B. To by-pass the water heater for winterizing, close valves A and C and open valve B (see illustration).

Open the hot side of the galley or lavatory faucet and turn on the water pump switch located on the monitor panel. For some time the open faucet will only sputter. This is because the water heater is being filled and air is being pushed out through the lines. Once the water heater is full a steady stream of water will come from the faucet. Now open a cold faucet. It will sputter for a short time, but will soon expel a steady stream. All other faucets can now be opened until all air is expelled.

Once the system is filled with water and the faucets closed, the water pump will shut off.

When a faucet is opened the pump will come back on automatically. If the faucet is just barely open it is normal for the pump to cycle on and off rapidly.

CAUTION: The water pump must be turned off when hooked up to city water supply and when you leave your Airstream unattended.

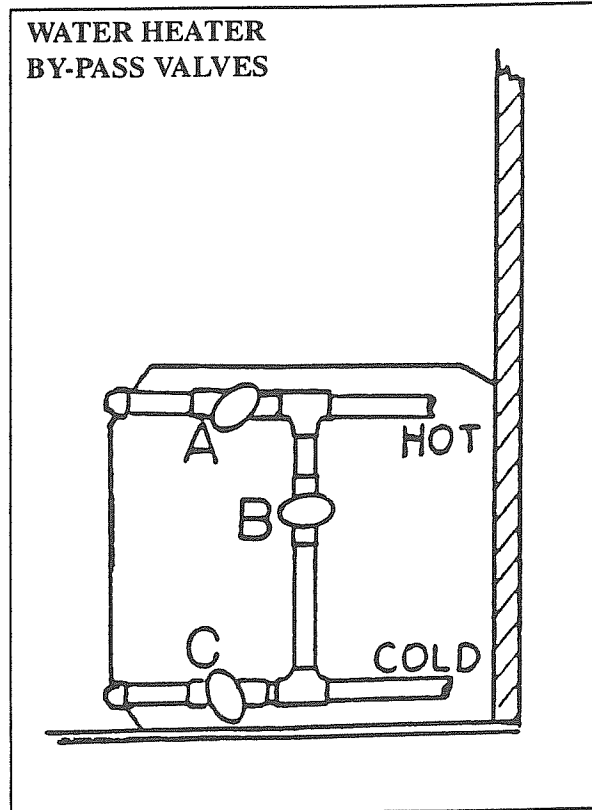

WATER PUMP AND STRAINER

The water pump and strainer are located under the rear bed. The strainer should be visually checked for accumulation of sand or debris that could affect water flow.

To clean strainer screen, first remove inlet connection from pump side of strainer. This will allow the intake side of the strainer to be rotated about 1/8 turn counter clockwise and removed. The screen part of the strainer will now be accessible for cleaning.

When reassembling only rotate the inlet side of the strainer until the stops are felt. Sealing is performed by the "O" ring and to much pressure will only break the strainer.

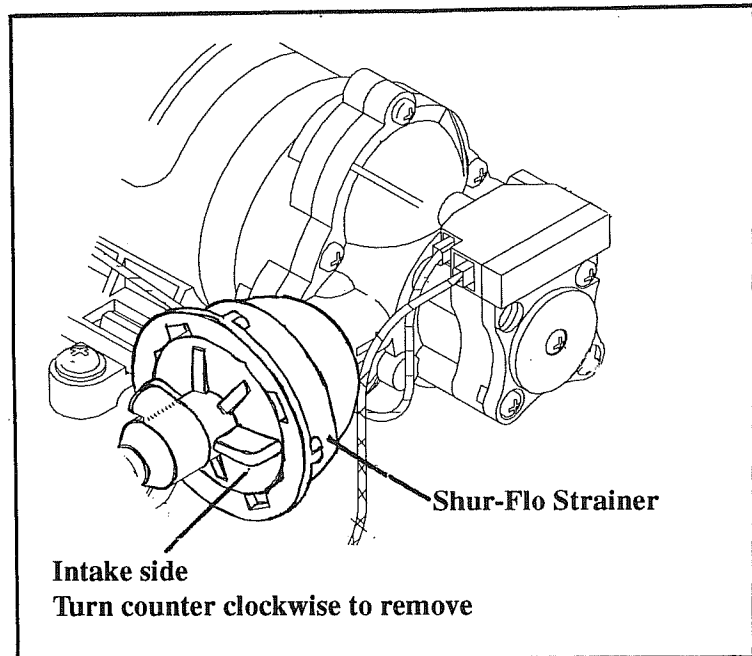

SANITIZING

Potable water systems require periodic maintenance to deliver a consistent flow of fresh water. Depending on use and the environment the system is subject to, sanitizing is recommended prior to storing and before using the water system after a period of storage. Systems with new components, or ones that have been subjected to contamination, should also be disinfected as follows:

1. Use one of the following methods to determine the amount of common household bleach needed to sanitize the tank.
 - A) Multiply "gallons of tank capacity" by 0.13; the result is the ounces of bleach needed to sanitize the tank.
 - B) Multiply "Liters of tank capacity" by 1.0; the result is the milliliters of bleach needed to sanitize the tank.
2. Mix into solution the proper amount of bleach within a container of water.
3. Pour the solution (water/bleach) into the tank and fill the tank with potable water.
4. Open all faucets (Hot & Cold) allowing the water to run until the distinct odor of chlorine is detected.
5. The standard solution must have four (4) hours of contact time to disinfect completely. Doubling the solution concentration allows for contact time of one (1) hour.
6. When the contact time is completed, drain the tank. Refill with potable water and purge the plumbing of all sanitizing solution.

NOTE: The sanitizing procedure outlined above is in conformance with the approved procedures of RVIA ANSI A119.2 and the U.S. Public Health Service.

WATER PUMP

Manufacturer:

Shur-Flo
1740 Markle Street
Elkhart, Indiana 46514
Phone: 219-294-7581

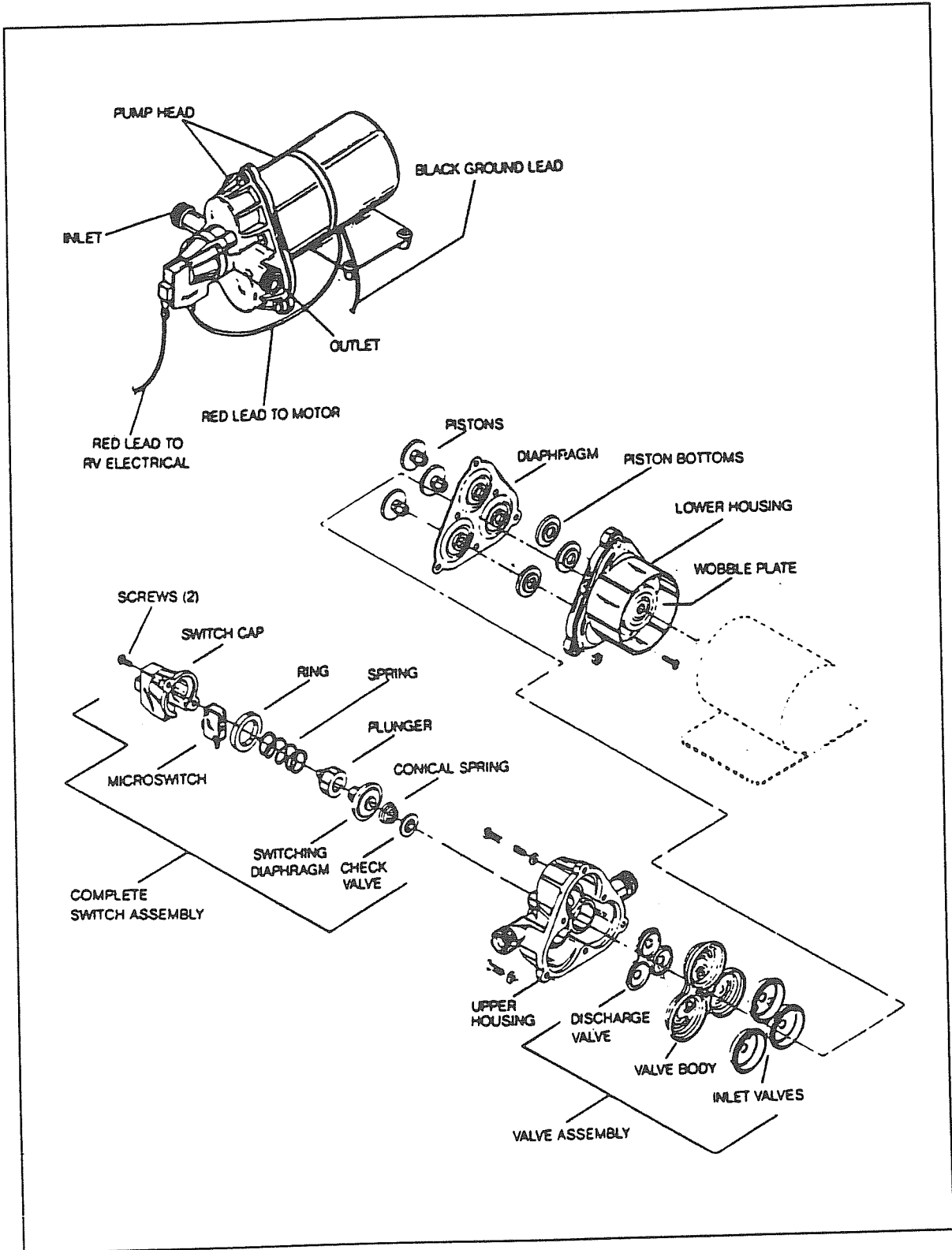

Switch and Check Valve Repair

The check valve, hydraulic switch mechanism and micro switch are accessible by removing the switch cover.

CAUTION: Care should be taken in removing the switch cover screws. Within the mechanism is a spring under compression.

Replacement of Micro Switch

Occasionally the micro switch fails or an electrode is broken off. Proceed as follows: Remove the two screws holding the cap to the main body. Remember, a spring under compression is retained by this cap. With both screws out, allow the spring to extend fully. Then carefully lift off cap and spring. If only the micro switch is at fault, avoid disturbing the hydraulic elements remaining in the head. If examination of the hydraulic parts is required, remove them carefully by pulling. Be sure to note the order of removal.

To replace the micro switch, remove the spring and pull out the black retaining ring. This will allow the micro switch to fall free. Replace parts in the reverse sequence: Micro switch, black retainer, and the spring.

Reassemble cover to the main body. Switch cap may be pointed up or down as desired, providing wire has not been shorted.

Having replaced the micro switch, be careful to rewire correctly.

Note: If the positive wire from the battery is connected to the "B" terminal, the switch is bypassed and the pump cannot shut off. Pressure will build up until the motor stalls. If the proper fuse has been used, it will blow. If a larger fuse than recommended has been used, the motor will stall and may burn out.

Check Valve Problems

Due to contamination from debris or lime build-up, the check valve may fail to properly seat. To correct, clean out the area and replace the check valve element. If checking the check valve with air be certain to moisten the check valve to get an accurate check. The rubber seals more effectively when wet.

Properly Installed, the Pump will:

PRIME: The pump will automatically prime itself.

AIR-LOCK: Pump will not air-lock as the compression stroke is powerful enough to pressurize the entrapped air and force the check valve open.

RUN DRY: Pump will run dry for extended periods without damage.

BATTERY DRAIN: At free flow, the pump draws a mere 7 to 7 1/2 amps.

CHECK VALVE: Built-in check valve prevents back flow and can protect the pump from the dangers of high city water pressure (up to 200 PSI).

FULLY AUTOMATIC: The pump will automatically come on when the faucet or valve is opened. It delivers a smooth, steady flow of water and shuts off automatically when the faucet is closed.

Trouble Shooting

MOTOR DOES NOT OPERATE.

- Is battery discharged?
- Are any wires disconnected?
- Are terminals corroded?
- Is switch in "ON" position?
- Is fuse good?
- Is water frozen in pump head?

MOTOR RUNS BUT NO WATER FLOWS.

- Is water tank empty?
- Are there kinks in the inlet hose?
- Is air leaking into inlet hose fittings?
- Is inlet line or in-line filter plugged?
- If using a filter, check the line just before the filter.
- Is outlet hose kinked?

MOTOR RUNS BUT WATER "SPUTTERS"

Check to be certain that air has been bled off the lines and water heater. Also check for air leaks in the input side of the pump.

PUMP CYCLES ON AND OFF WHEN ALL OUTLETS ARE CLOSED.

The pump will normally cycle (go on and off) when a faucet is partially opened. If, however, it cycles when all valves are closed, check for a leak in the lines. It may be a leaky toilet valve or a dripping faucet. Do not forget to check the outside city water entry valve. It may be leaking.

If no leak can be detected, shut pump off. Remove the output hose where it joins the system (not at the pump). Insert a plug in the hose and clamp it. (You can make a perfect plug from a barb fitting: 1/2" size with a cap tightly screwed on the threads.) Turn the pump switch on. The pump should come on, run a few seconds, and then shut off. If it remains off, the problem is NOT the pump. The problem is in the system. If, however, the pump goes on and off, there may be a problem in the pump.

There may be an internal leak in the pump which allows water to escape from the high pressure area back into the low pressure area. Look for a pump valve held open or a crack in the plastic parts.

PUMP DOES NOT ACHIEVE SHUT OFF

The wall switch may be used for temporary control of the pump. A low battery charge may be the cause. Or the pump switch mechanism may be stuck. Try tapping the switch cap on the end of the pump with the handle of a screwdriver. If the pump appears in all other respects to run normally, but fails to shut off, you may have to replace the switch mechanism.

PUMP HEAD LEAKS

If the pump head leaks, first try to tighten the screws in the pump head assembly until they are snug.

CAUTION: Do not over tighten. The leak may be from a crack in the pump head assembly. If so, then replace.

One cause of the pump head cracking may be water freezing inside the pump head. If the leaking water is escaping back near the motor, check for a leaking or broken piston.

Pump Repair

Screws (A) hold the entire pump head assembly to the motor.

Screws (B) hold the pump head face to the pump head main body.

Screws (C) hold the switch assembly to the front of the pump head.

Screws (A) would be removed to correct a problem in the “drive train” between the motor and pump head.

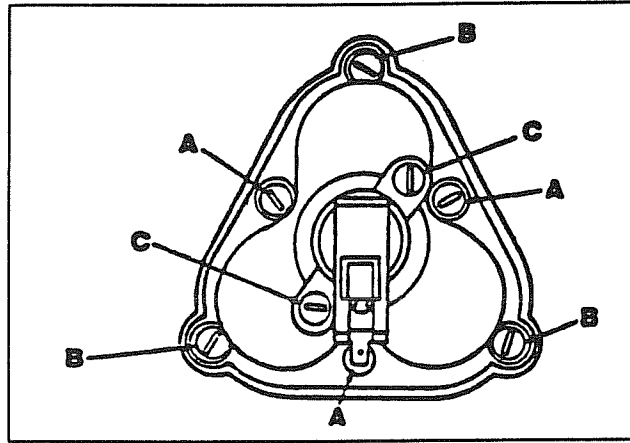

Screws (A) and (B) would be removed to correct a problem in the pump head valves or pumping chambers.

Screws (C) would be removed to correct a problem in the automatic switch or check valve.

PUMP HEAD REPAIR

Motor and drive train area. Rarely does a problem occur in this area of the pump head. If a part does fail, it is quite easily replaced. Just be certain to follow closely the sequence of parts as shown in the figure. Also be careful to align the flat surface in the drive adapter with the flat surface on the motor shaft.

LUBRICATION

If the lubricant appears dried out it should be wiped off the bearing assemblies. A small amount of automotive wheel bearing grease should be applied to both sides of each bearing.

FAILURE TO PRIME

Failure to prime can be caused by the presence of some foreign matter lodged in the valve preventing it from seating. To correct, remove any such foreign bodies.

CAUTION: Do not remove the stainless steel screens. These filter screens should be cleaned without removing them from the plastic housing.

PUMP CHAMBER REPAIR

Replacement of broken piston.

To remove a piston, back out the screw holding the defective piston.

Now lift the corner of the diaphragm and remove the broken piston. Insert the new piston through the diaphragm and slide the retaining ring on. Rotate the piston until it drops into place in the drive plate. Replace the screw and tighten until snug.

CAUTION: Do not attempt to re-use a piston once it has been removed. The plastic stem, if used a second time, may not hold securely. The second thread path removes additional material and there is then no real bite.

REPLACE A DIAPHRAGM

To replace a diaphragm follow the procedure used in removing the pistons. After removing the three pistons the diaphragm is loose and easily removed.

Screws (A) hold the piston.

Screws (B) hold the drive mechanism and should not be removed when replacing piston.

CITY WATER HOOKUP

Use a high pressure hose of at least 1/2" diameter. It should be one that is tasteless, odorless and non-toxic designed for RV use. The city water inlet is a standard garden hose thread. We suggest you carry two lengths of hose. This way you have the ability to reach hookups further away

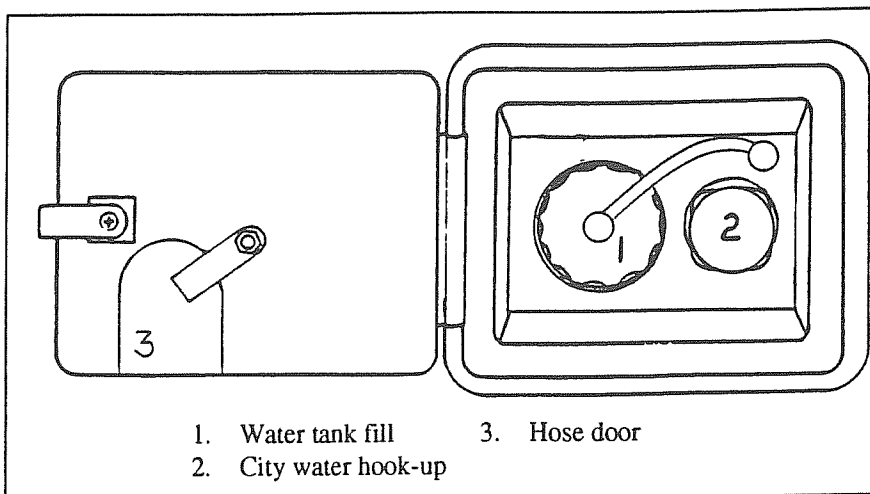

than normal, plus you have a spare hose should one fail or become damaged unexpectedly. Turn the water heater bypass to the normal flow position as described under self contained.

After hooking up the hose and turning on the city water valve provided in the park, slowly open a faucet. There will be a lot of spurts and sputtering until all the air is expelled from the motorhome system. If the water heater is empty it will take some time before all the air is expelled and you get a steady flow of water at the faucet. Once a steady flow is achieved at one faucet the others should be opened long enough to expel the air in the lines going to them.

During city water operation the water pump switch should be in the off position. A check valve built into the pump protects it from city water pressure.

Your plumbing system has a built in pressure regulator to protect your lines and faucets from extremely high pressures on some city water systems.

BLACK TANK FLUSH

In the utility compartment on the left rear lower side is a water hose connector marked "black tank flush". To use, hook-up hose and turn on full force. Within the tank a spray head with a multiplied holed head will spray the interior surface of the tank.

The gate valve should be closed for the first couple of minutes then opened to let the water out in a rush. Repeat as needed.

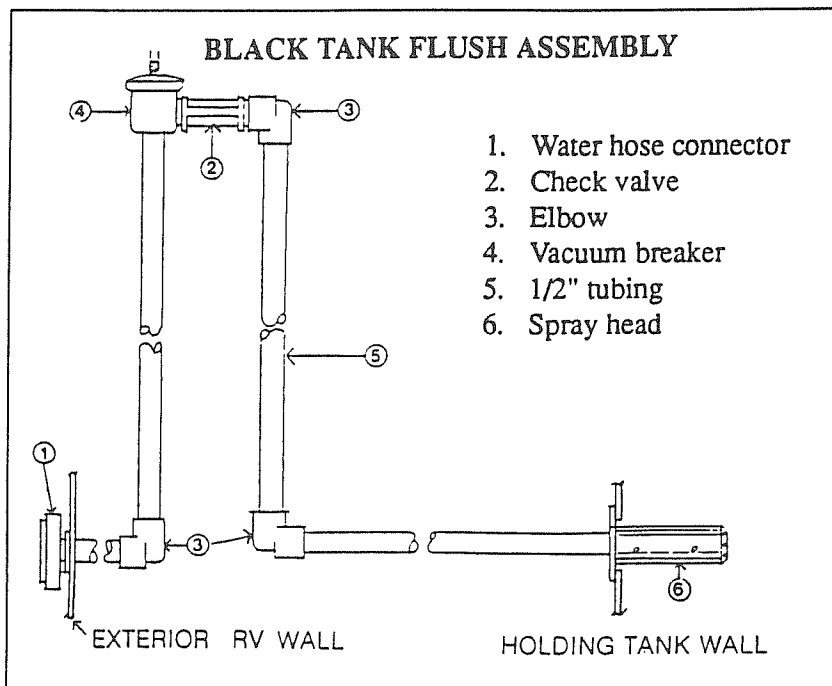

EXTERIOR WATER SERVICE

Next to the black tank flush is a second water hose hook-up with a shut off valve. This is plumbed in to the high pressure water system of the motorhome. This is an ideal place to rinse the sand off your feet after going to the beach, cleaning mud off your boots and hundreds of other messy jobs that are better done outside of your motorhome.

EVERPURE WATER FILTER (OPTIONAL)

The filter is located under the galley sink. It will remove even very fine dirt and colloidal matter, and eliminates most chlorine, phenol and similar distasteful odors and tastes, while delivering sparkling taste-free water for drinking and cooking. The filter is connected to the cold water galley drinking faucet only. The filter will also remove iron and sulphur provided the water supply is chlorinated. super-chlorination will precipitate the iron and sulphur which will then be removed by the QC-2 Filter. To purify any questionable water fill the Everpure Chlorine Disinfectant Dispenser with liquid bleach and add 1/6 ounce (one teaspoonful) per 10 gallons of water in the water tank. The water will remain sparkling clear even to the end of the filter pack life, however, as the minute pores slowly fill up with impurities the flow rate will be gradually reduced. When it becomes too slow for convenience the cartridge can be very simply changed. Follow the instructions on the cartridge. We advise keeping a spare cartridge at all times.

To Remove Used Cartridge:

1. Shut off water by lifting valve handle counterclockwise as far as possible.
2. Turn colored ring all the way to the left. Ring will drop about 5/8".
3. Lift cartridge slightly and turn it further to the left until it can be disengaged.
4. Lower cartridge to disengage it from ring. Discard used cartridge.

To Install New Cartridge:

1. With colored ring in lowered position (turned all the way to the left), orient lug on cartridge with cutout under label on ring.
2. Insert cartridge straight up into ring as far as it will go. Holding colored ring steady, turn cartridge as far to the right as possible, without forcing.
3. The turn colored ring far to right to drive cartridge up into head.
4. To lock ring in place and turn water on, move valve handle down. Be sure handle leg engages ring locking-lug.

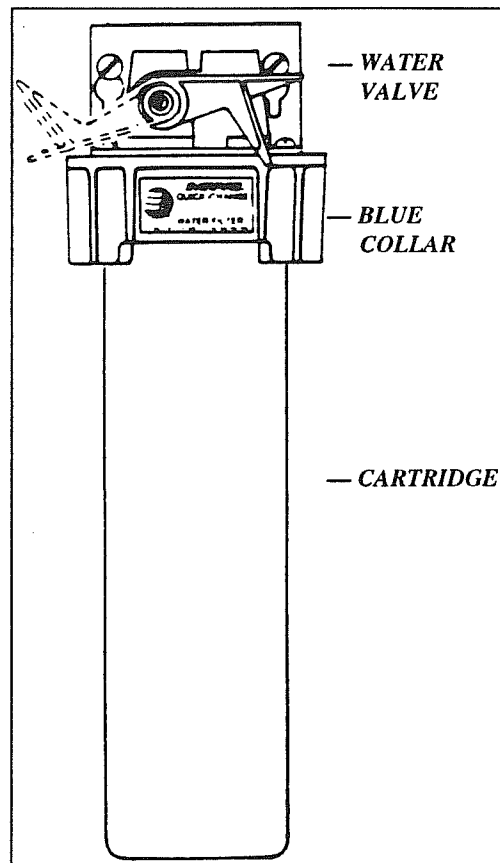

Everpure water Filter

FAUCET, ONE TOUCH

Care and Cleaning

The surface of the faucets will stay bright and resist wear with a minimum of care. Strong detergents may tend to dull the finish. So when cleaning a faucet use only mild soap and water.

The finish on the faucets has been designed to retain its polished appearance without scouring. Stains and dirt remove easily without the use of scouring powders or abrasive polishes and cleaners. Use of such agents may cause scratches which mar the finish, and in time become dirt catchers and unattractive.

MOEN FAUCET CARTRIDGE REPLACEMENT

Disassembly:

Turn OFF both hot and cold water supplies, then open faucet to relieve pressure and insure that water has been COMPLETELY shut off.

1. Carefully pry off handle cover with flatbladed instrument. Remove handle screw, using Phillips screwdriver.
2. Lift handle up and off. Unscrew and remove collar and pivot retainer being careful not to damage the finish.
3. Unscrew and remove retainer nut, o-ring, bearing washer, and washer. Pry out cartridge clip with a flat bladed instrument.
4. Using a Moen cartridge twisting tool (as furnished in the model 1225 cartridge pack, or a Moen cartridge puller) turn cartridge shell back and forth with pliers to loosen.
5. Gripping the cartridge stem with pliers, pull cartridge up and out of faucet body.

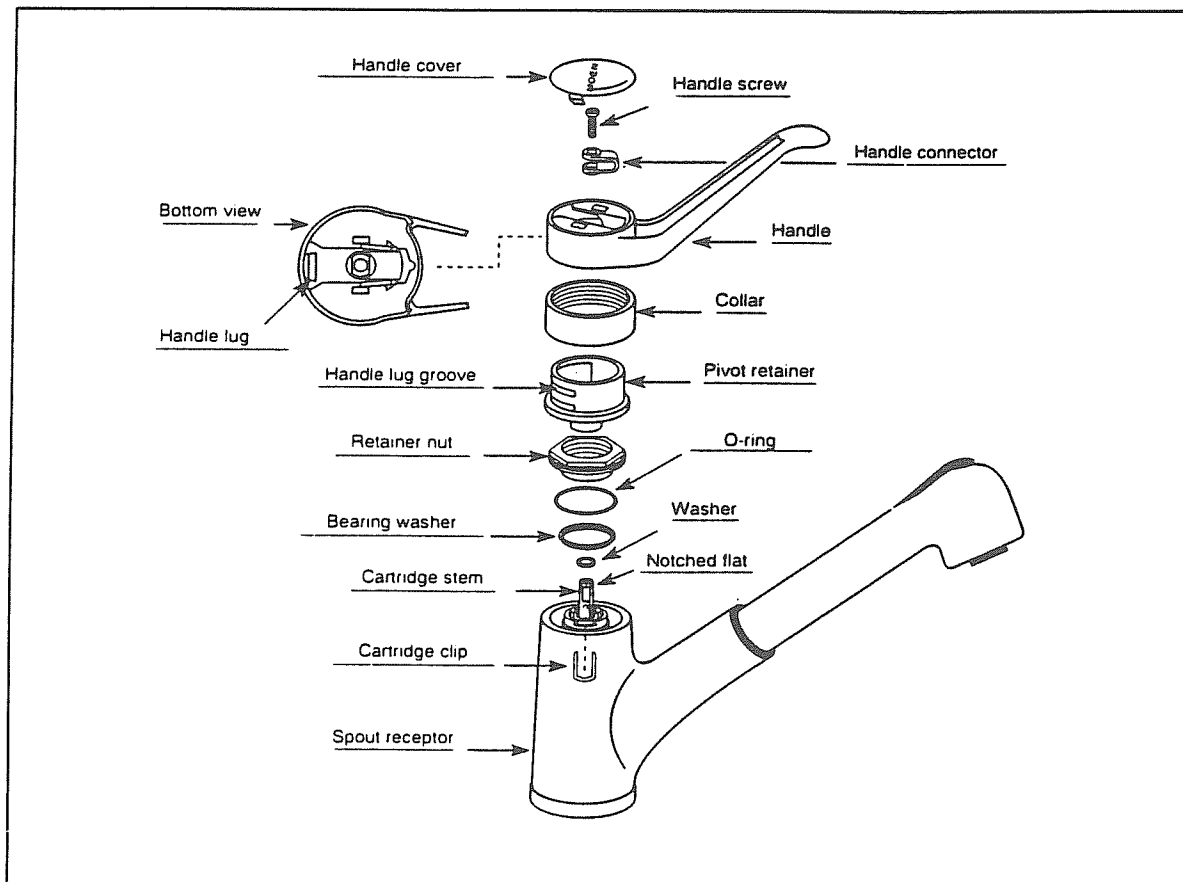

Reassembly:

1. Be sure that cartridge ears are aligned with the slots in the valve body, front to back. With cartridge stem UP, insert new cartridge assembly by pushing down on top of cartridge ears.
2. Re-install the cartridge clip, washer, bearing washer, O-ring, and the retainer nut. Tighten snugly by hand.
3. Re-install pivot retainer with grooves facing the back of the faucet. Replace the collar, tighten snugly by hand. Replace the washer.
4. With cartridge stem notch facing forward, hook handle lug into handle lug groove. Align handle connector with cartridge stem and gently press handle onto cartridge stem.
5. Replace handle screw and press on handle cap.

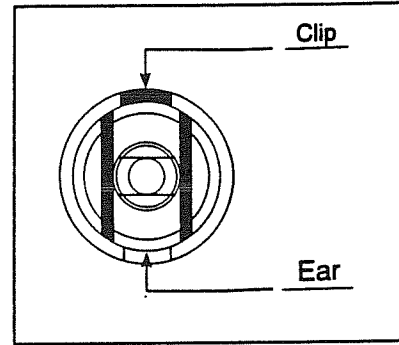

TO REMOVE AND CLEAN CHECK VALVE:

1. Unscrew pull-out spout from hose connection.
2. Using a thin-bladed instrument, carefully pry out check valve from spout, be careful not to damage O-ring.
3. Thoroughly flush check valve under warm faucet water.
4. Re-install as shown, making sure gasket is in place in hose connection.

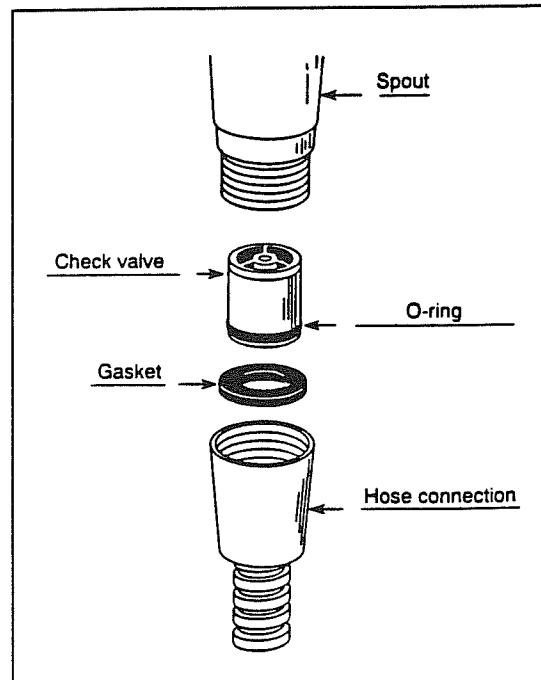

MOEN FAUCET CARTRIDGE REPLACEMENT

Disassembly:

Turn OFF both hot and cold water supplies, then open faucet to relieve pressure and insure that water has been COMPLETELY shut off.

1. Carefully pry off handle cover with flatbladed instrument. Remove handle screw, using Phillips screwdriver.
2. Lift handle up and off. Unscrew and remove collar and pivot retainer being careful not to damage the finish.
3. Unscrew and remove retainer nut, o-ring, bearing washer, and washer. Pry out cartridge clip with a flat bladed instrument.
4. Using a Moen cartridge twisting tool (as furnished in the model 1225 cartridge pack, or a Moen cartridge puller) turn cartridge shell back and forth with pliers to loosen.
5. Gripping the cartridge stem with pliers, pull cartridge up and out of faucet body.

Reassembly:

1. Be sure that cartridge ears are aligned with the slots in the valve body, front to back. With cartridge stem UP, insert new cartridge assembly by pushing down on top of cartridge ears.
2. Re-install the cartridge clip, washer, bearing washer, O-ring, and the retainer nut. Tighten snugly by hand.
3. Re-install pivot retainer with grooves facing the back of the faucet. Replace the collar, tighten snugly by hand. Replace the washer.
4. With cartridge stem notch facing forward, hook handle lug into handle lug groove. Align handle connector with cartridge stem and gently press handle onto cartridge stem.
5. Replace handle screw and press on handle cap.

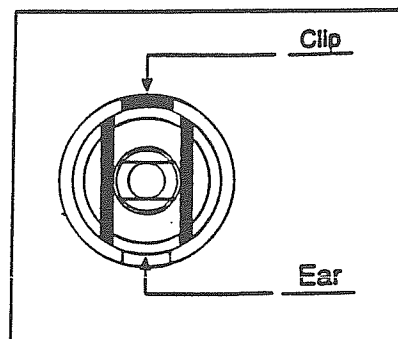
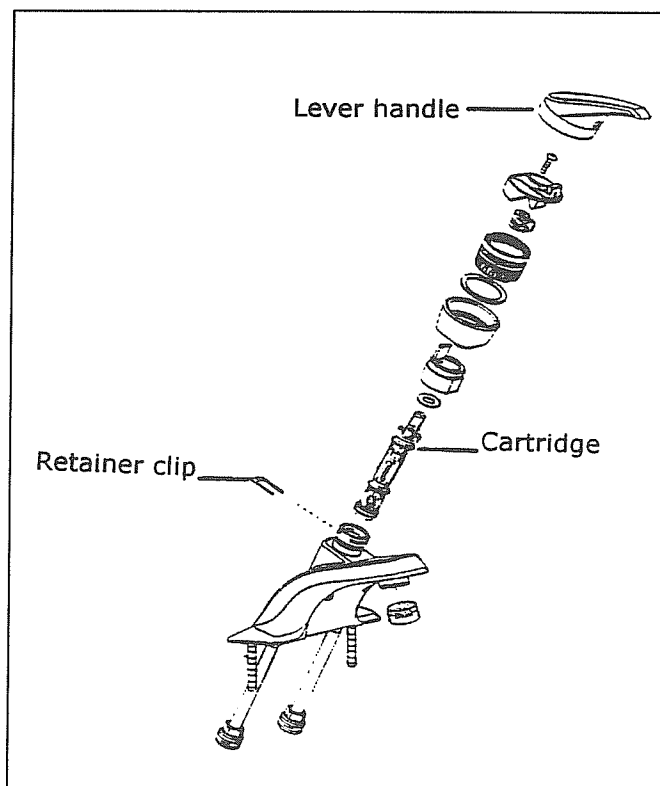

**MOEN LAVATORY
FAUCET**

1. Retainer Clip
(Knob Handles)
2. Valve Cartridge
3. Handle Cover
(Knob Handles)
4. Stop Tube
(Knob Handles)
5. Aerator - Male Thread
6. Handle Screw
(Knob Handles)
7. Handle Assembly
(Knob Handles)

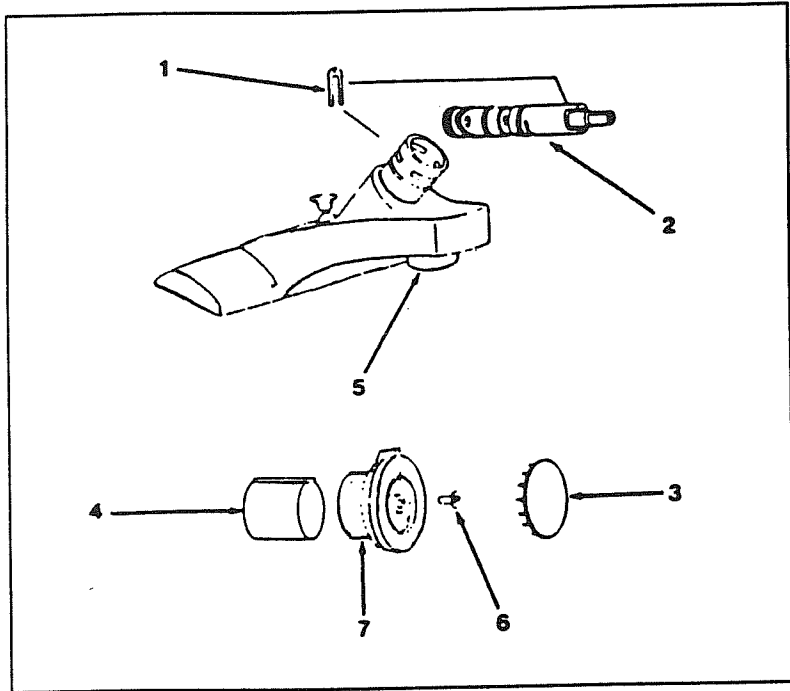

Removal and Replacement

1. Disconnect city water supply.
2. Shut off pump switch.
3. Open faucets.
4. Open drain valves.
5. Remove hose clamps holding plastic hot and cold water lines to copper pigtails on faucet. Remove lines.
6. Form lines from faucet so they are paralleled with one another.
7. Remove nuts and washers securing faucet in place.
8. Remove faucet by lifting it from its position.
9. To replace, reverse above procedure.
10. Check for leaks.

NOTE: See end of faucet section for removal of cartridge.

**MOEN SHOWER MIXING
VALVE ASSEMBLY**

1. Handle Cover
2. Handle
3. Cartridge
4. Handle Screw
5. Valve Body
6. Stop Tube
7. Retainer Clip

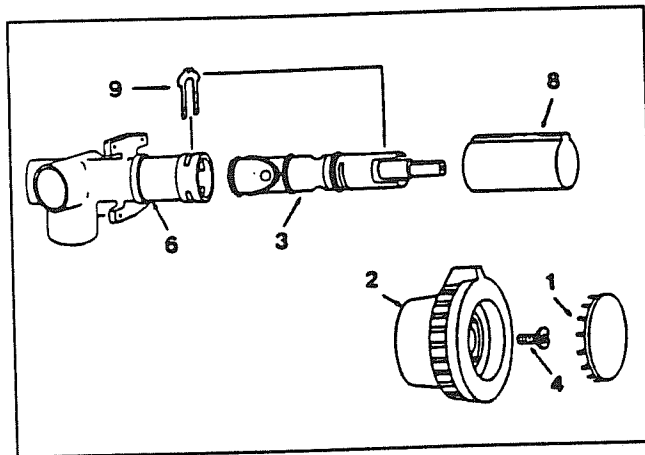

Removal and Replacement

1. Cover carpet and cover bottom of shower pan to protect them from damage.
2. Disconnect city water. Shut off water pump.
3. Open drain valves
4. Open galley, lavatory and shower faucets and allow water to drain from lines.
5. Remove screws from top of faucet inspection cover in wardrobe. Tip back and remove water lines from faucet.
6. Pop out metal insert in control valve handle. Remove screw and pull knob off.
7. Remove screws in escutcheon plate.
8. Disconnect shower hose.
9. Wrap masking tape on chrome fitting so as not to scratch chrome.
10. Using wrench, remove fitting.
11. Mixing valve, shower outlet, tube and hot and cold feed line assemblies may then be removed through wardrobe inspection hole.
12. Replace by reversing above procedure.

NOTE: If existing hose clamps were destroyed in removal, they should be replaced with screw type clamps.

LAVATORY FAUCET AND SHOWER MIXING VALVE CARTRIDGE REMOVAL

Shut off water pressure for entire system.

Disassemble: Remove handle cover. Take out handle screw and remove handle and stop tube. Lift out retaining clip and pull the cartridge out of the body by the stem.

CAUTION: Reinsert cartridge by pushing it all the way into the body and until the front of the ears on the cartridge shell are flush and aligned with the body. Replace the retainer clip so that the legs straddle the cartridge ears and slide down into the bottom slot in the body. This prevents the cartridge from rotating and locks it in the body. Reinstall stop tube and handle. Tighten handle screw securely, and replace the handle cover. The red flat on the stem must point UP when mounting the knob handle (down for lever handle).

If cold water is on left side and hot water is on right side (red flat pointed down), remove cartridge and reinstall 180°.

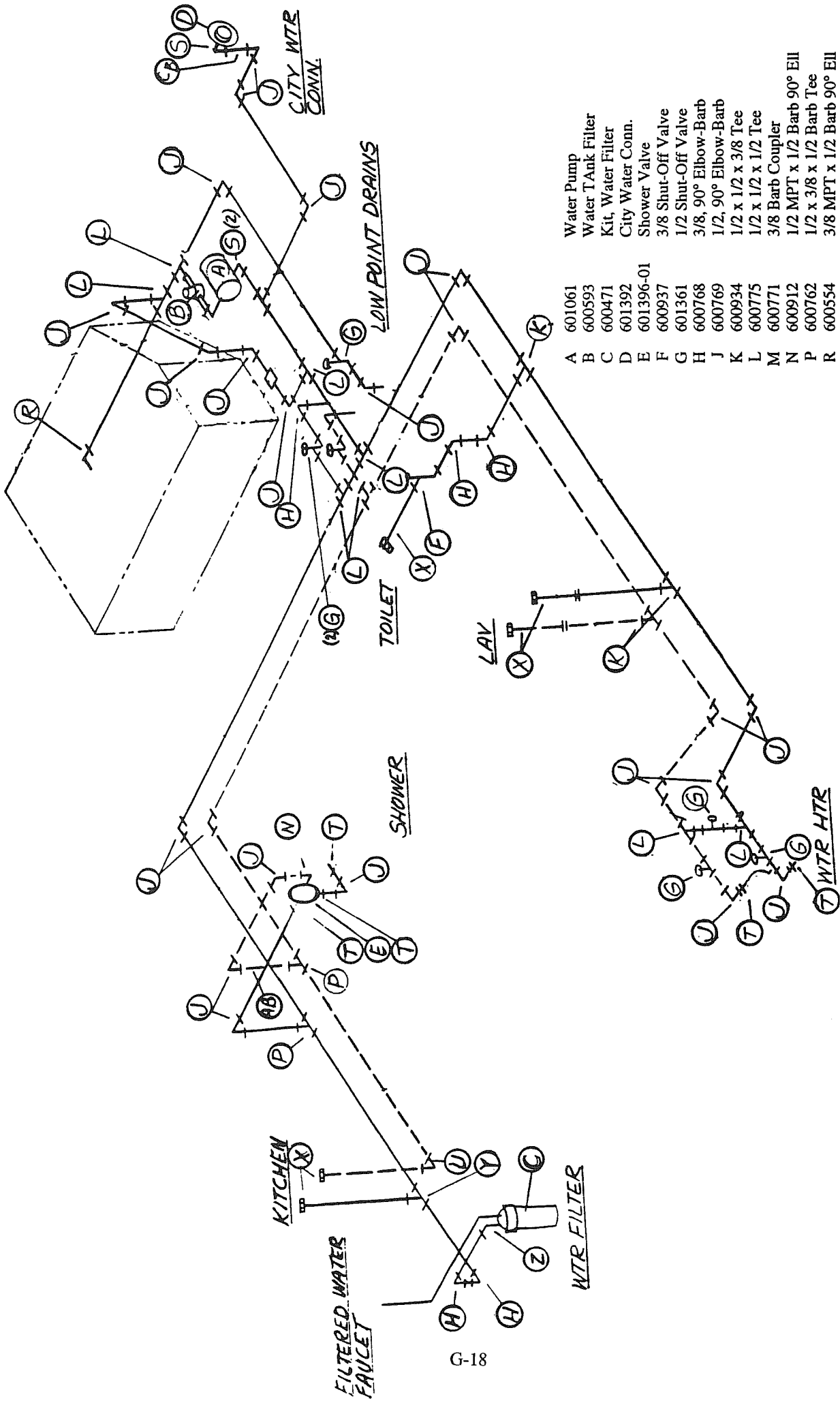

A	601061	Water Pump
B	600593	Water Tank Filter Kit, Water Filter
C	600471	City Water Conn.
D	601392	Shower Valve
E	601396-01	3/8 Shut-Off Valve
F	600937	1/2 Shut-Off Valve
G	601361	3/8, 90° Elbow-Barb
H	600768	1/2, 90° Elbow-Barb
J	600769	1/2 x 1/2 x 3/8 Tee
K	600934	1/2 x 1/2 x 1/2 Tee
L	600775	3/8 Barb Coupler
M	600771	1/2 MPT x 1/2 Barb 90° Ell
N	600912	1/2 x 3/8 x 1/2 Barb Tee
P	600762	3/8 MPT x 1/2 Barb 90° Ell
R	600554	1/2, 90° Swivel Elbow
S	601293	1/2 MPT x 1/2 Barb Coup.
T	600760	1/2 x 3/8 90° Barb Ell
U	600999	3/8 Water Line Riser
V		3/8 x 3/8 x 3/8 Barb Tee
W	601165-01	3/8 MPT x 3/8 Barb Tee
X	600763	3/8 MPT x 3/8 Barb Tee
Y	600913	3/8 MPT x 3/8 Barb Tee
Z		3/8 MPT x 3/8 Barb Tee

DRAIN AND HIGH PRESSURE WATER VALVES

Your Land Yacht motorhome has 10 water valves not counting your interior faucets.

3 - Are located under the front of the double bed behind the hinged doors. One each for draining hot and cold water lines and the third drains the water tank. If you have a twin bed model, these 3 valves would be located under the curbside twin bed.

3 - More valves are for the water heater by-pass system.

access - 30 foot - pull off panel below wardrobe

33 foot - open lavatory cabinet and pull out vertical panel

1- Valve is the brass exterior service valve in the roadside rear utility compartment

1- Another valve will be inside the coach on the exterior service line. During cold weather usage you'll want to close the valve and open the brass exterior valve so it won't freeze and burst.

access - 30 foot - under lavatory

33 foot - open lavatory cabinet and pull out vertical panel

1- Valve is for the optional icemaker

access - 30 foot - under stove

33 foot - under galley way back against wall

TOILET

Manufacturer: Thetford Corporation
7101 Jackson Road
Ann Arbor, MI 48103
313-769-6000

The RV toilet in your Airstream is a design that has been used for many years. There are two pedals. The large pedal opens and closes the slide mechanism, and the smaller pedal opens and closes a water valve.

In normal use, when you are hooked up to city water, both pedals are depressed together. This dumps the sewage and fresh water and flushes down the side of the bowl. Water will continue to run into the bowl for a short time after the pedals are released.

When you wish to conserve water, hold the handspray head over the bowl and hold down the thumb-operated lever. Now, when you depress the pedal, all the water is routed through the handspray.

CAUTION: When you dump the bowl of the toilet, make sure all paper and solids have cleared the slide mechanism before you allow it to close. Failure to do so can cause the groove for the slide to become jammed, and the slide will no longer close completely.

If the problem should occur, a small nail or bent clothes hanger can be used to “pick” the material out of the groove.

TROUBLE SHOOTING

PROBLEM: Water keeps running into bowl.

CAUSE: The blade in the bottom of the bowl is not closing completely, which in turn keeps the water control valve partially open. The groove into which the blade seats when completely closed is clogged with foreign material.

REMEDY: Insert the end of a coat hanger or similar object into the sealing groove and remove the foreign material. Avoid damaging the rubber seal while cleaning.

PROBLEM: Toilet leaks. There is water on the floor. Specify the problem. Determine if water is leaking from:

- CAUSE:**
- a. Vacuum breaker.
 - b. The water-control valve.
 - c. Bowl to mechanism seal. (If this is the problem, the water would not stay in the bowl.)
 - d. Closet flange base seal.

- REMEDY:**
- a. The vacuum breaker. If the vacuum breaker leaks when flushing the toilet, replace vacuum breaker.
 - b. If the vacuum breaker leaks when the toilet is not in operation, replace the water control valve.
 - c. Leaks at the bowl to mechanism seal. Remove mechanism and replace seal.
 - d. Leaks at closet flange area. Check front and rear closet flange nuts for tightness. If leak continues remove the toilet, check the closet flange height. The height should be between 1/4" and 7/16" above the floor. Adjust closet flange height accordingly and replace closet flange seal.

PROBLEM: Foot pedal operates harder than normal or the blade sticks.

- REMEDY:**
- a. Apply a light film of Silicone spray to blade.
 - b. Check closet bolt tightness. If closet bolts are over tightened, the mechanism may be distorted.

PROBLEM: Bowl will not hold water; i.e., water leaks from bowl down into the holding tank.

REMEDY: Using a bent screwdriver or similar object, scrape the groove in front of the mechanism blade. Generally paper or other foreign material is lodged in this groove, causing the leak.

CAUTION: *Use care not to damage the blade seal. Always make certain that the tool is under the lip of the seal, not above it.*

The tool can easily be made by bending a coat hanger or screwdriver over about 7/8".

MAINTENANCE

If the bowl sealing blade does not operate freely after extended use, it may be restored to its original, smooth operating condition by applying a light film of silicone spray to the blade. To clean the toilet use Thetford Aqua Bowl or any other high grade, non- abrasive cleaner. Do not use highly concentrated or high acid content household cleaners. They may damage the rubber seals.

REMOVAL

1. Shut off water valve behind toilet or main water supply.
2. Disconnect water supply line from toilet. You will probably find a small mirror very useful.
3. Depress pedal and remove nut located in pedal recess.
4. Reach behind toilet and remove nut on opposite side of base from pedals. In some situations you may want to remove the plug in top of the seat designed to give access from above to this nut.

NOTE: Always replace flange seal when toilet has been removed.

VACUUM BREAKER ASSEMBLY AND DISASSEMBLE

Remove vacuum breaker from toilet. Remove 10 screws holding the cover to the housing. This exposes the vacuum breaker float, float seal, and cover seal. The float is free in its chamber and is easily lifted or dumped out.

NOTE: When reassembling the unit, make sure the housing is free of dirt and the raised collar that the float sits on is clean and free of burrs.

When the cover is reinstalled, it is important that the screws be turned backwards until they jump, so that when they are tightened they are in the original thread.

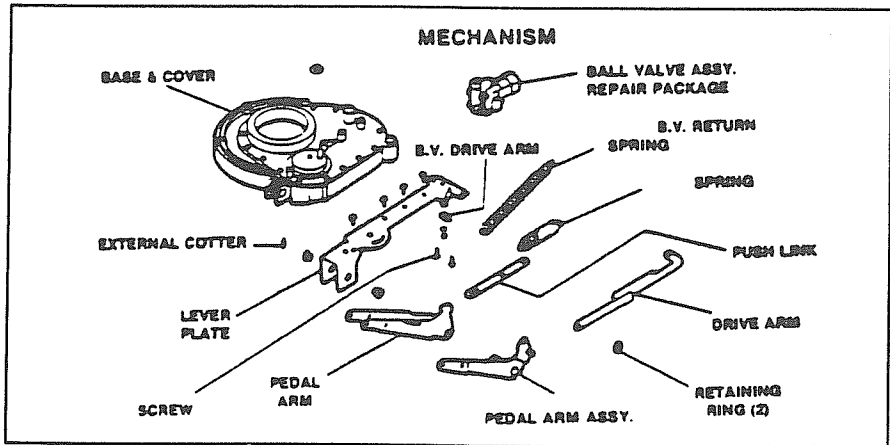
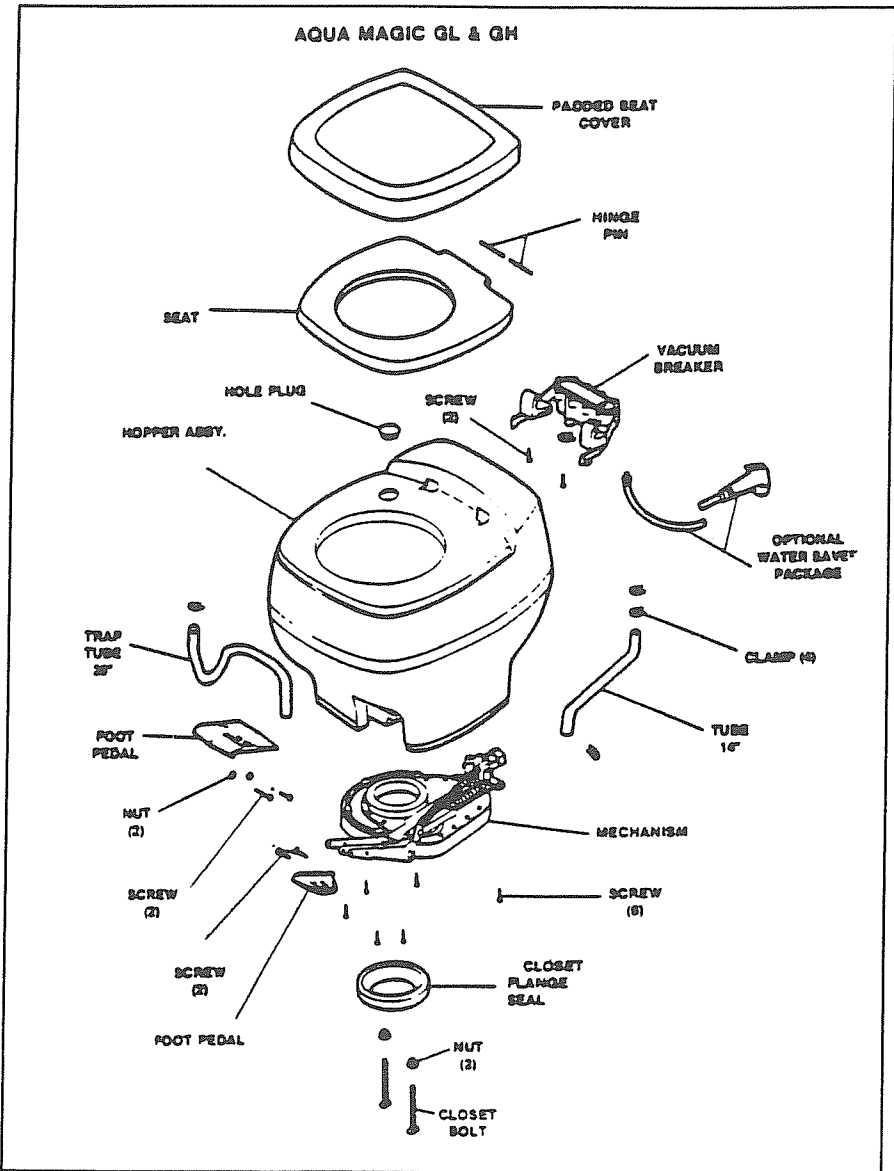

DRAIN LINES, BELOW FLOOR

33 FOOT

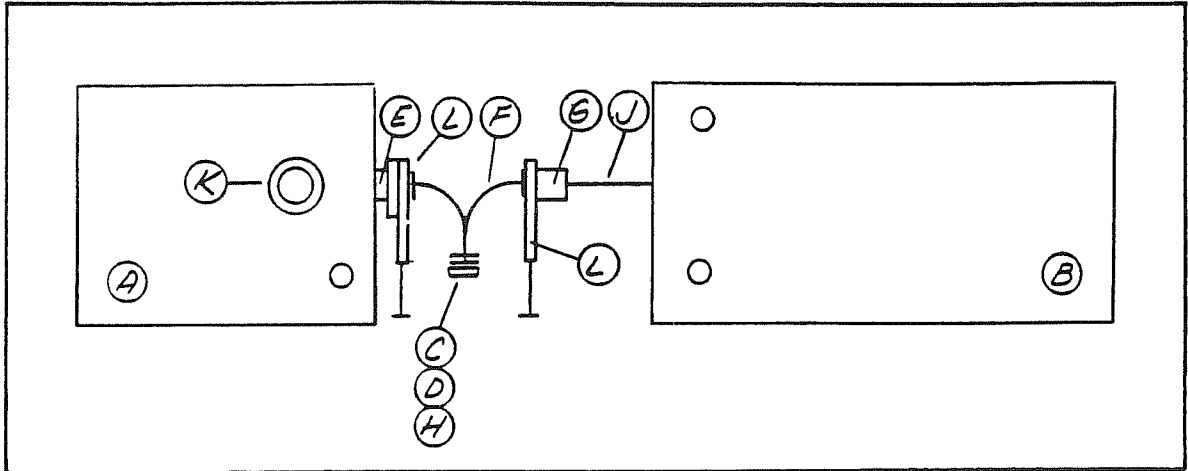

- | | | |
|---|-----------|---------------------|
| A | 601493 | Black Tank |
| B | 601492 | Grey Tank |
| C | 601251 | Bayonet Ring |
| D | 601250 | Bayonet Cap |
| E | 601432 | Adapter |
| F | 600866 | 3 Way Elbow |
| G | 600289 | 3" Coupler |
| H | 601160-04 | 3" Dia x 3" |
| J | 601160-04 | 3" Dia x 10" |
| K | 601266 | 4 x 3 Closet Flange |
| L | 601430 | 3" Gate Valve |

30 FOOT

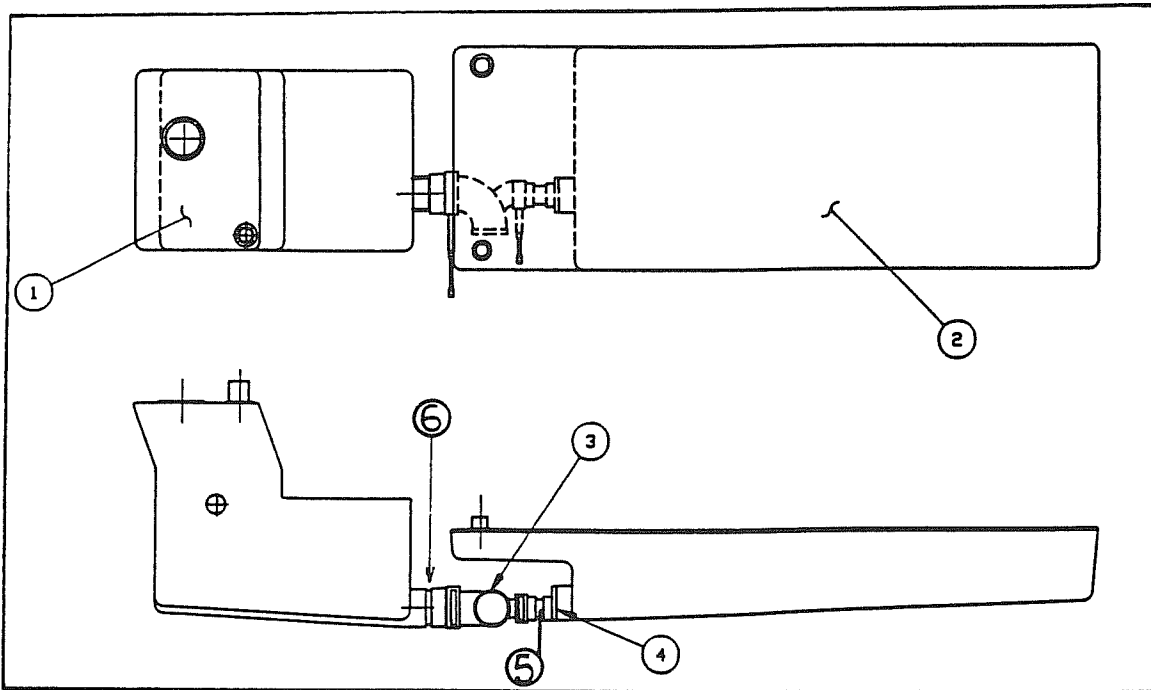

- | | | |
|---|------------|----------------------------------|
| 1 | 601567 | Tank Black Holding |
| 2 | See 109992 | Tank Grey Holding |
| 3 | 601482 | Dump Valve Rotating Assy. |
| 4 | 195329-229 | Reducer Adapter 3" to 1.5" 40740 |
| 5 | 601160-04 | Pipe, ABS DVW, 3" |
| 6 | 601160-02 | Pipe, ABS DVW, 1-1/2" |

33 FOOT, DRAIN LINE, ABOVE FLOOR

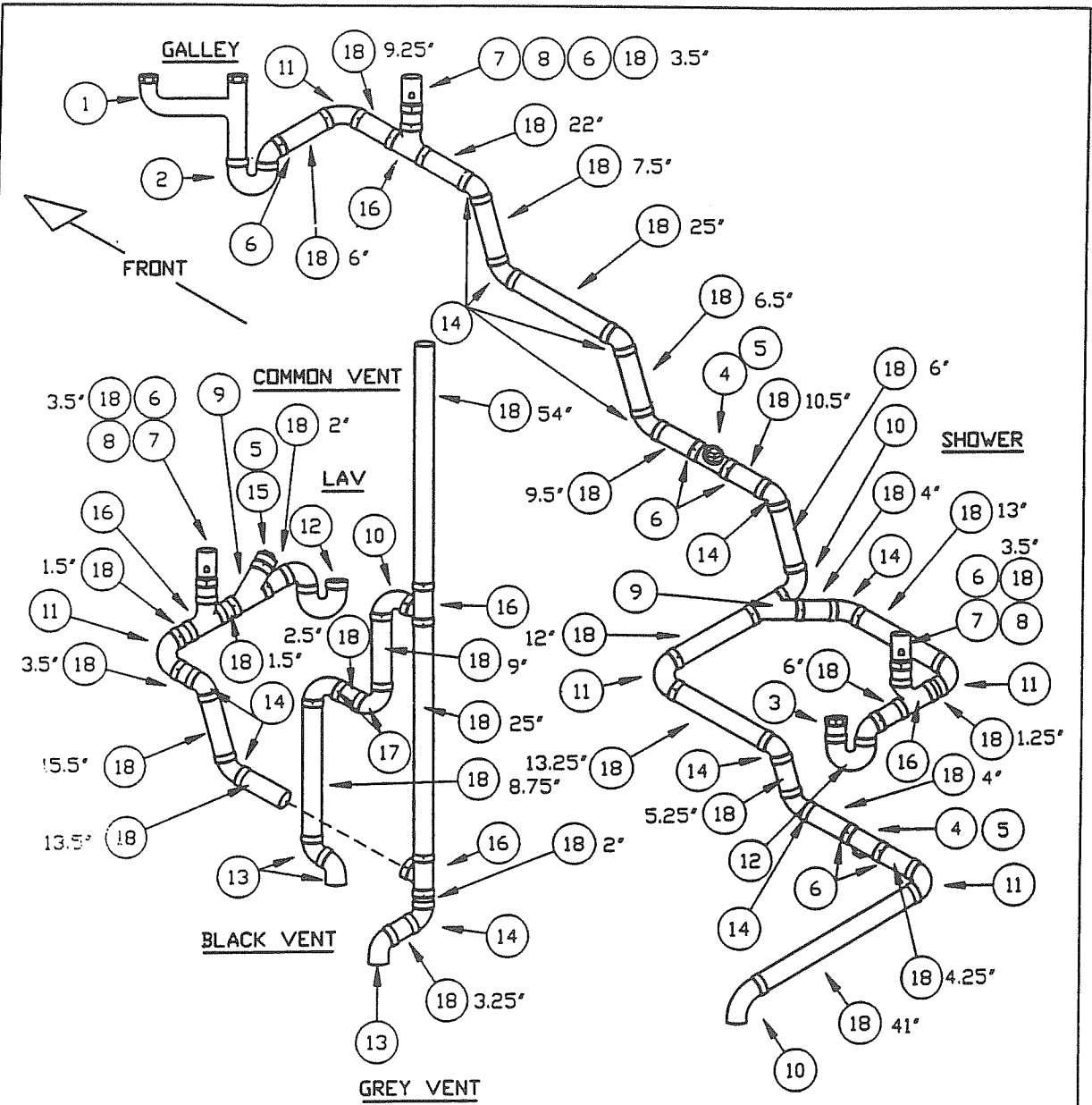

1	600378	Continuous Waste 1 1/2
2	600144	P-Trap ABS 1 1/2 In.
3	601201	Adapt. Swivel Strainer, 1.25", 62691
4	601318	Tee Bi-Directional Cleanout 1 1/2
5	600155	Plug, Cleanout 1 1/2
6	601263	Bushing 1.5 x 1.25 ABS
7	600538	Vent V-200 Automatic
8	600308	Adapter ABS Female Sloan #2891
9	601305	1.25", 45° Wye
10	601440	1.25", 90° Degree XLT St. Ell
11	601199	1.25", 90° XLT Ell
12	601202	P-Trap W/Union, 1.25" #62615
13	600027	1.25", 45° St. Ell
14	600030	1.25", 45° Ell
15	#	1.5 x 1.25 Reducing Female Adapter
16	601198	Sanitary Tee, 1.25" All Hub, #61508
17	601308	1.25", 90° Vent Ell
18	601160-01	Pipe, ABS DVW., 1.25"

30 FOOT, DRAIN LINE, ABOVE FLOOR

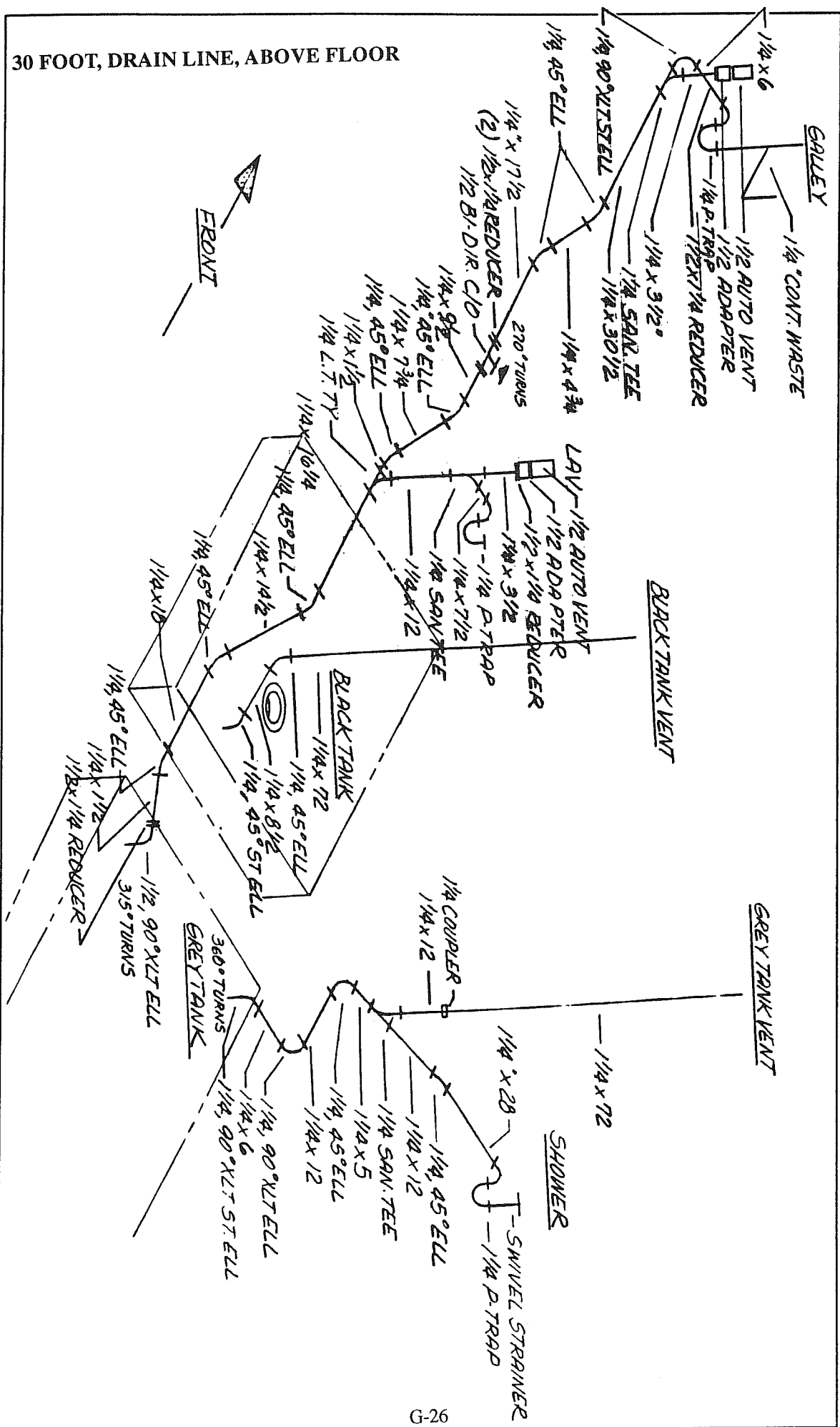

STORAGE AND WINTERIZING

When storing your motorhome for a short or long period, use the same precautions as you would in your own home in regard to perishables, ventilation and rain protection. In addition, for prolonged storage periods, flush out all the drain lines and the holding tanks. Also, drain the entire water system, including the water heater and the water storage tank. Instructions for draining the water system are explained in the following paragraphs on winterizing.

Twice a year, or after a long storage period, we suggest you take your unit into your Airstream dealer for a check-up and cleaning of the gas operated appliances

Living Area

The main consideration in winterizing is to guard against freezing damage to the hot and cold water systems, the waste drain system (including the traps), the waste holding tanks, the water heater and the batteries. To completely winterize your motorhome follow this procedure:

1. Level the motorhome from side to side and front to rear. Open all faucets.
2. Turn the water pump switch to the OFF position.
3. Open all drain valves. One drain valve or plug on all models is located on the water heater exterior and is accessible through the water heater access door.

On rear double bed models three additional valves are located under the bed. One for hot lines - one for cold lines and the third for draining the water tank.

On rear twin bed models these same valves are located under the curbside rear twin bed.

Other valves to open would be exterior service valve and the in-line exterior service valve. (See drain valves and access further forward in this section.)
4. The toilet water valve should be left in open position while draining water. It is located in the lavatory cabinet. Remove the toilet drain plug, the water line and screen. (See diagram under TOILET section of this manual.) Then depress flush lever until all water drains from the system.
5. While the water is draining from the system, depress hand spray thumb button on the telephone shower head and drain all the water. Unscrew the head on spray unit and store.
6. After the water has stopped running from the drain lines, apply at least 60 lbs. of air pressure at the city water inlet. Be sure the toilet valve and all drain valves and faucets are open and pump outlet hose is disconnected. This can be accomplished at a service station and will force any remaining water from the water heater and remove any water which may be trapped in low areas.
7. Pour a cup of non-toxic antifreeze into the lavatory, sink, and tub drains to prevent freezing water in traps.
8. Be sure to open the waste holding tank drain valves, and drain and flush the tanks thoroughly. (This is very important, as the sewage in the tank, if frozen, could seriously damage the tank.)
9. Remove water filter canister and dump.
10. Remove the batteries from your motorhome and store in a cool dry place where there is no danger of freezing. It is very important for optimum life of your battery to check it periodically and to keep it fully charged. This is especially true in winter months, when the temperature may drop below freezing. If the period of storage is for 30 days or less, you may turn off the "kill" switch rather than remove the batteries.

Please refer to the battery section for more information on battery maintenance

11. Remove any items (food, cosmetics, etc.) from the interior that might be damaged by freezing, or might damage the motorhome if containers break.

For additional winterizing protection, add non-toxic antifreeze (approved for drinking water systems) to your water lines using the following procedure:

1. Reconnect all lines except the hose to the pump inlet port. Close all drain valves (See Step 3).
- * 2. Turn bypass valves to bypass position.
3. Attach a length of hose to the pump inlet port. This piece of hose should be long enough for the free end to be inserted into and reach the bottom of the antifreeze container.
4. Dilute the antifreeze solution in accordance with the manufacturer's instructions.
5. Open all water faucets.
6. Insert hose length into the antifreeze container, turn the pump switch on, and run the water pump until the antifreeze solution fills all water lines. Flush toilet. Work shower hand spray while holding down in tub.
7. Shut off the pump and close all faucets.
8. Disconnect the hose length from pump inlet fitting and reconnect water system inlet line.

*To by-pass the water heater for winterizing, close valves A and C and open valve B (See illustration).

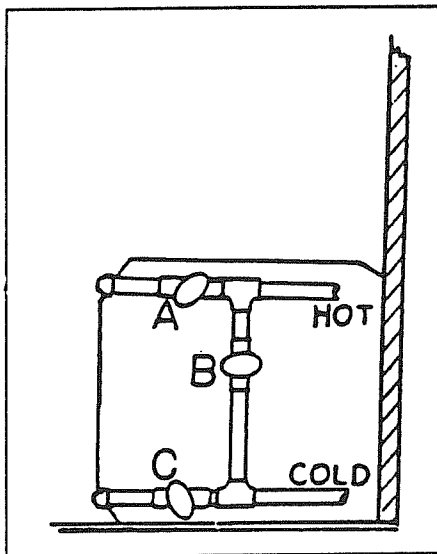

DRAIN AND WASTE SYSTEM

The drain and waste system of your motorhome includes waste holding tanks made from molded plastic. The MAIN HOLDING TANK enables you to use the toilet for several days away from disposal facilities. The waste water from the sink, shower, and bath and lavatory drain into the AUXILIARY HOLDING TANK. Each tank has its own dump valve; however, both tanks drain through a common outlet. Therefore, you need to make only one connection when hooking up in a trailer park with sewer facilities.

Monitor Panel

Check your monitor panel frequently. When the MAIN HOLDING TANK is completely full, sewage cannot be emptied from the toilet bowl. If the AUXILIARY HOLDING TANK is overfilled, drain water will "backup" into the tub and cause an unpleasant cleaning job. Never drain the tanks at any place other than an approved dumping station.

To empty both tanks, attach the sewer hose by pressing the bayonet fitting onto the outlet adapter and rotate clockwise until it feels solid and secure. Attach the outlet end of the hose to the sewage outlet, making sure that the hose is placed so that it will drain completely. The dump valves are located on the lower rear roadside corner of the motorhome. Pull the dump valve handle out as far as it will go and wait until the tank is drained. If the auxiliary tank is drained after the waste tank, the soapy water will help keep the sewer hose and outlet clean.

The main holding tank must be flushed out until all paper and waste material is removed. Close the dump valve and refill the tank with 5 to 10 gallons of clean water and repeat until clean.

When Parked and Connected to Sewer Outlet

When you are in a park and connected to a sewer outlet, keep the main holding tank dump valve closed, and empty the tank every few days or whenever it becomes almost full. **ONLY BY SENDING A LARGE VOLUME OF LIQUID THROUGH THE MAIN HOLDING TANK AT A TIME WILL TOILET PAPER AND OTHER SOLIDS COMPLETELY WASH AWAY.**

This practice will avoid the accumulation of solids in the main holding tank, which could lead to an unpleasant cleaning job. Should solids accumulate, close the dump valve, fill the tank about half full with water, then drive the motorhome for a few miles. The turbulence and surging of the water will usually dissolve the solids into suspension so the tank can be drained. Keep the auxiliary tank valve open when connected to a sewer outlet.

Draining the tanks as described will protect them from freezing during storage. When traveling in sub-freezing temperatures, use a winterizing solution designed for RV use. Follow the directions on the container. As this is being written, heated tanks are being considered and may be on your motorhome.

CAUTION: Never put wet strength paper towels or tissues in your holding tank, since they won't dissolve and can "catch" in the mechanism of the dump valve. Colored toilet tissue is slower to dissolve than white. Most RV accessory stores offer tissue, designed for RVs, that will completely dissolve.

Black Tank Flush

On the left rear lower side is a water hose connector marked "black tank flush." To use, hook-up hose and turn on full force. Within the tank a sprayhead with a multiple-holed head will spray the interior surface of the tank.

The gate valve should be closed for the first couple of minutes, then opened to let the water out in a rush. Repeat as needed.

Drain Systems Cleaning

There are many deodorizers on the market in tablet, liquid, and powder form. These not only combat odor, but stimulate the bacteria that works to dissolve the solids in your tank. Picking a deodorizer with lubricating qualities will ease slide valve operation.

The only cleaning agents that can be used without causing harm to the system are household ammonia and trisodium phosphate in small quantities. Do not use any product that contains any portion of petroleum distillates. This attacks the rubber seals of your toilet and dump valve. Also, do not use any dish detergent or abrasive cleaners. All products should be marked approved for ABS drainage systems.

When winterizing drains use only recreational vehicle plumbing type antifreeze. These are sold through your dealer.

NOTES

ELECTRICAL SYSTEM

12 VOLT SYSTEM

BATTERIES

Your Airstream Land Yacht motorhome is equipped with three batteries: one engine battery and two coach batteries.

Engine Battery

The engine battery is used for starting the engine and operating the headlights, tail-lights, running lights, instrument panel lighting, automotive air conditioning and other accessories. The engine battery is charged by the alternator while driving and the solar panel.

Coach Batteries

The coach batteries are used for interior lighting, exhaust fans, generator, water pump, central control panel, entertainment center, optional 12 volt convenience outlets, and the refrigerator when it is switched to 12 volt power. These batteries are charged by the engine's alternator when driving, or by the converter when plugged into 120 volt city power. They are also charged by the generator, when it is running, through the 120 volt city power system.

Interior Lights

Many interior lights have been included in your motorhome to give you almost infinite variable light intensity.

There are two main clusters of light switches. Just inside the main door on the galley end panel are switches for the auxiliary battery, step, patio light and forward ceiling lights. The forward ceiling lights must have their switches on before the remote switch on the galley end panel will control them. The auxiliary battery switch connects and disconnects the batteries providing current to your interior circuit. Use it for short term storage. If you're not going to use the motorhome for a week or more, shut the switch off. When using the motorhome, leave it on.

The second cluster of switches is in the bathroom. They control the bath lights, water heater and water pump.

The water pump switch operates in conjunction with the pump switch on the monitor panel. The pump can be turned on or off at either location.

The water heater switch supplies power to the ignitor and gas valve. When turned on it will flash red until flame is sensed, then the red light will be extinguished.

The bulbs in the interior lights are all easily replaced if they burn out. Round, exposed bulbs, such as those around the bathroom mirror and reading lights, are replaced by depressing them into their base, then turning to the left about 1/4 turn. This will allow them to "pop" out part way so they can be removed.

WARNING: If they are difficult to turn, use a folded rag to protect your hand when grasping the bulb in case it should unexpectedly shatter.

The ceiling and wardrobe light lenses are removed by squeezing the sides of the lens in until they clear the frame. In cold weather it is helpful to leave the light on for a while to soften the plastic and avoid cracking. Incandescent bulbs are removed by depressing and turning to the left about 1/4 turn. Fluorescent bulbs are removed by turning in either direction.

12 Volt Operation

The only thing you have to do is make sure the two auxiliary batteries don't run down. In normal usage there isn't any problem, since you would normally drive part of the day and be plugged into a camp ground at night. The alternator charges the batteries when you drive and when you're plugged into city power the convertor charges the coach batteries and carries much of the load.

Some nights you may not find a place to plug into city power. No problem; the batteries total about 210 amp-hours, so you can comfortably run your lights and vents in a normal fashion without depleting the batteries.

If you are not plugged into city power and you're not driving, you'll want to conserve your batteries by using as few lights and appliances as possible. If you notice the lights becoming dim, it's much easier on the batteries if you go ahead and start the engine or generator before the batteries run down.

There are two sets of fuses in your motorhome. The main interior circuits are in the 12-volt distribution panel behind the motor cover. The brightly colored fuses pull straight out from the face of the panel. Replacement fuses are available at automotive stores and most service stations.

The second set of fuses are Chevrolet fuses to the left of the steering column. The function of the fuses are marked directly on the face of the fuse block. See your Chevrolet Drivers Manual for further information on chassis items. A diagram is in this section showing where Airstream picks up power for automotive accessories.

Basic 12V Wiring

On the following page is a drawing of the 12 volt wiring system used in your motorhome.

The batteries, both solenoids, power distribution block, and the isolator are all located under the front hood.

The auxiliary battery disconnect switch seen on the left side of the drawing, is just inside your main door. Leave it on if you are using the motorhome. Turn it off if the motorhome is not going to be used for a few days or more.

On the upper right of the drawing is an auxiliary start switch. The switch is one of those in the vertical row on the right side of your dash and controls the auxiliary start solenoid.

The auxiliary start solenoid is your built in battery jumper. If your engine battery is low you can press the auxiliary start switch on the dash and the solenoid will close tying all three batteries into the start circuit.

The 12 volt distribution panel in the upper center of the drawing is mounted under an access door directly behind the motor cover. From here the 12 volt power is distributed to each of the 12 volt interior circuits of the motorhome

The power distribution block is simply a junction block allowing a secure connection between large O gauge wires.

The isolator keeps your two battery systems separated when you are parked. This way if you leave some interior lights on you won't run down your engine battery. When the engine is started, power from the alternator is fed through the isolator to both the engine and auxiliary batteries.

9S2503

CONTROL PANEL GEN. START SWITCH

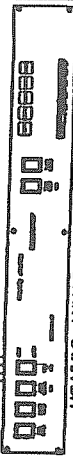

LET DATE E.C.N.

REVISION RECORD

BY

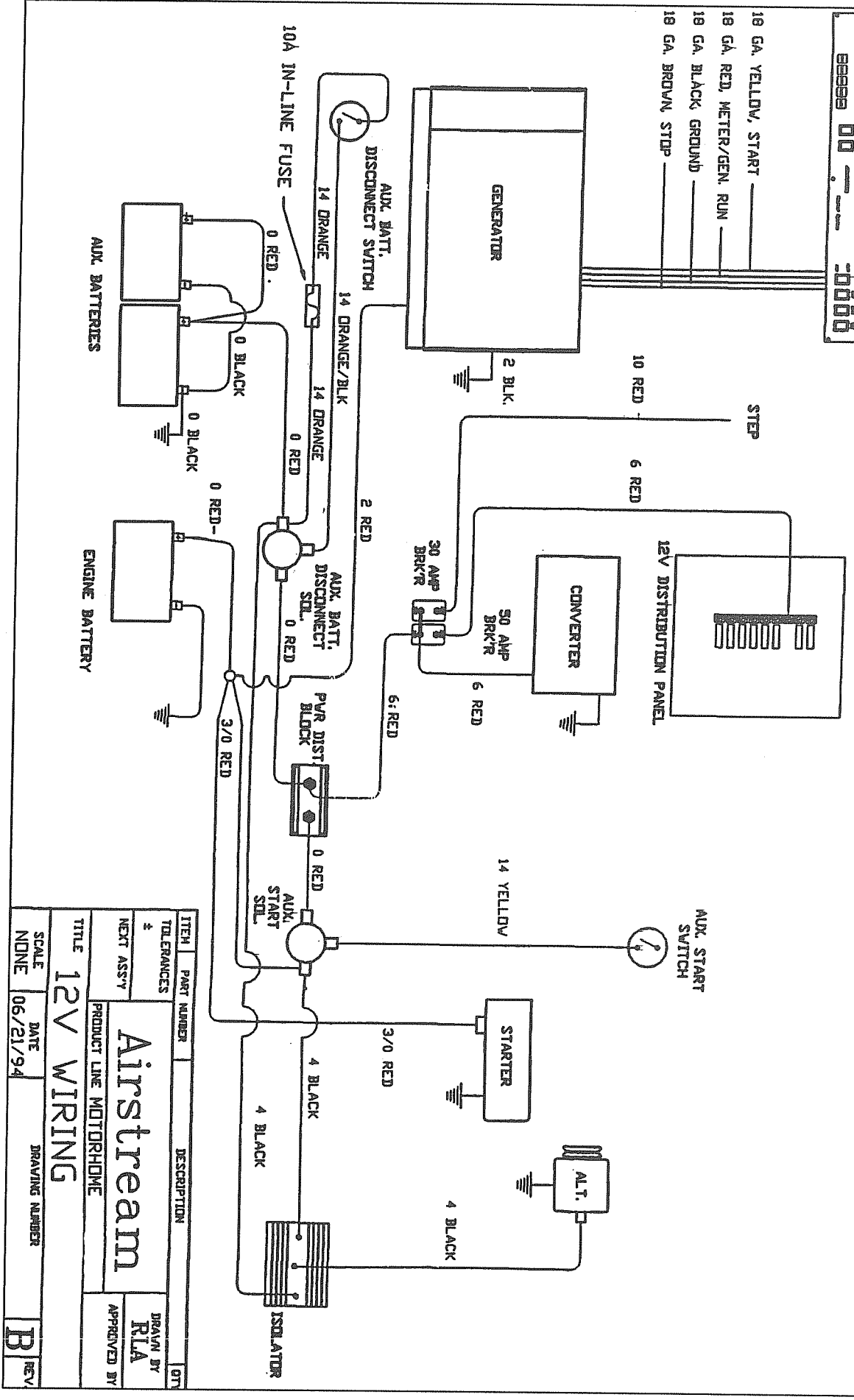

ITEM	PART NUMBER	DESCRIPTION	QTY
TOLERANCES			
NEXT ASS'Y			
PRODUCT LINE MOTORHOME			
DRAWN BY RLA			
APPROVED BY			
TITLE 12V WIRING			
SCALE	DATE	DRAWING NUMBER	
NDNE	06/21/94		
			REV B

12V WIRING DIAGRAMS

- 12 volt fuse panel - Airstream
- 12 volt calculations - 30 ft.
- 12 volt calculations - 33 ft.
- 12 volt fuse panel - Chevrolet
- 12 volt - firewall - 1
- 12 volt - firewall - 2
- 12 volt - firewall - 3
- 12 volt - firewall - 4
- 12 volt - chassis - 1
- 12 volt - chassis - 2
- 12 volt - chassis - 3
- 12 volt - body interior
- 12 volt - ceiling
- 12 volt - "A" post
- Keyless entry
- Electric Mirrors
- Wipers
- Dash Switches
- Dash Lights
- Head Lights
- Tail Lights
- Drivers Door
- Coax Cable Splitter

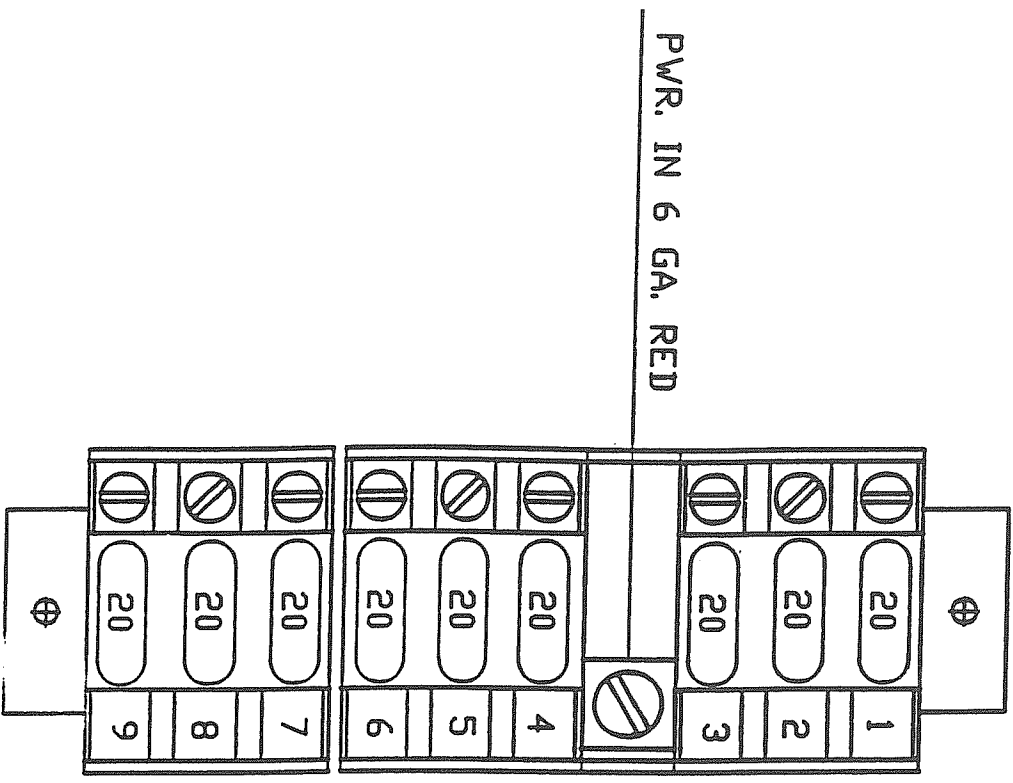

FUSE POSITION

- #1 CIR. 7, 12 GA. ORANGE
- #2 CIR. 7, 12 GA. ORANGE
- #3 CIR. 1, 12 GA. PURPLE
- #4 CIR. 2, 12 GA. YELLOW
- #5 CIR. 4, 12 GA. BROWN
- #6 CIR. 5, 12 GA. BLUE
- #7 CIR. 6, 12 GA. RED
- #8 CIR. 16, 12 GA. BLACK
- #9 CIR. 9, 12 GA. GREEN

FDR INDIVIDUAL CIRCUIT DETAILS
SEE 12V. CALCULATION SHEETS.

USAGE: 360 A/S MH., 360 A/S PUSHER
33' L/Y MH., 36' L/Y MH.,
34' L/Y PUSHER.

ITEM	PART NUMBER	DESCRIPTION	QTY
TOLERANCES	±		
NEXT ASSY	Airstream		
TITLE	12V. FUSE PANEL		
SCALE	DATE	DRAWING NUMBER	REV.
NONE	10/21/93	952456	A
DRAWN BY		APPROVED BY	
R.L.A.		R.L.A.	

LET DATE	E.C.N.	REVISION RECORD	BY
1/94	#	Production Release	RA

9524-u
 Fuse Position 1, Circuit 7, 20 A. Fuse, 12 Ga. Orange
 Refer 9.00 Amps

Fuse Position 2, Circuit 7, 20 A. Fuse, 12 Ga. Orange
 Refer 9.00 Amps

Fuse Position 3, Circuit 1, 20 A. Fuse, 12 Ga. Purple
 (2) 1-Bulb PD Bedroom Locker Lights 2.88 Amps
 #6 Bedroom Ceiling Light 1.70
 (2) 2-Bulb Wall Lamps 5.60
 Bedroom TV 4.20
 (1) 2-Bulb Vanity Light 2.00
Total 16.38 Amps

Fuse Position 4, Circuit 2, 20 A. Fuse, 12 Ga. Yellow
 Bath Exhaust Fan 2.00 Amps
 Water Heater Ignition 1.00
Total 3.00 Amps

Fuse Position 5, Circuit 4, 20 A. Fuse, 12 Ga. Brown
 Front Compartment Light 1.00 Amps
 Front TV 7.00
 (2) 2-Bulb Aisle Lights .60
 (2) 1-Bulb Aisle Lights .30
 Patio Light 1.04
 (2) Step Lights 2.00
 Front Radio 5.00
Total 16.94 Amps

Fuse Position 6, Circuit 5, 20 A. Fuse, 12 Ga. Blue
 Credenza D/H Light .90 Amps
 Lounge D/H Light .90
 Galley D/H Light .90
 'Fantastic' Ceiling Fan 3.30
 TV Booster 0.00
Total 6.00 Amps

Fuse Position 7, Circuit 6, 20 A. Fuse, 12 Ga. Red
 Furnace 6.50 Amps
 (7) Compartment Lights 7.00
Total 13.50 Amps

Fuse Position 8, Circuit 16, 20 A. Fuse, 12 Ga. Black
 #'s 1,2,3,4 and 5 Ceiling Lights 8.50 Amps
 (2) Wardrobe Lights 1.40
 Shower Fan 1.10
 3- Bulb Dinette Light 3.40
Total 14.40 Amps

Fuse Position 9, Circuit 9, 20 A. Fuse, 12 Ga. Green
 Range Vent and Light 3.20 Amps
 Water Pump 7.00
 Oven Light 1.00
Total 11.20 Amps

Battery Charger 3.00 Amps. Total Amp. Draw 102.42
 1st 20 Amps. @ 100% = 20.00 Amps.
 2nd 20 Amps. @ 100% = 10.00 Amps.
 62.42 Amps. @ 25% = 15.60 Amps.
Total 45.60 Amps

45.60 Amp. converter required by calculation.
 Todd 50 Amp. converter used.
 All appliances installed per manufacturer's
 Instructions per NEC 551-10 (e-3).

ITEM	PART NUMBER	DESCRIPTION	QTY	UOM
TOLERANCES	DRAWN BY R.L.A.			
±	APPROVED BY			
NEXT ASSY	Airstream			
PRODUCT LINE 30' L.Y. Mh.				
TITLE 12V. Calculations				
SCALE 1=1	DATE 02/15/94	DRAWING NUMBER 952490	REV. A	

Circuit 1, 20 Amp. Fuse, Orange
Refer 9.00 Amps.

Circuit 2, 20 Amp. Fuse, Orange 9.00 Amps.

Circuit 3, 20 Amp Fuse, Purple
(2) 1 Bulb PD Bedroom Locker Lights 2.88 Amps.
#5 Bedroom Fluorescent Light 1.70
(2) 2 Bulb Wall Lamps 5.60
Bedroom TV 4.20
R/S Wardrobe Light .70
Total 15.08 Amps.

Circuit 4, 20 Amp. Fuse, Yellow
Bath Fan 2.00 Amps.
(1) 3 Bulb Vanity Light 3.50
Bath Ceiling Fluorescent Light 1.70
Water Heater Ignition 1.00
Total 8.20 Amps.

Circuit 5, 20 Amp. Fuse, Brown
Front Compartment Light 1.00 Amps.
Front TV 7.00
(2) 2 Bulb Aisle Lights .60
(2) 1 Bulb Aisle Lights .30
Patio Light 1.04
Step Light 1.00
Front Radio 5.00
Total 15.94 Amps.

Circuit 6, 20 Amp. Fuse, Blue
C/S Living Area O/H Fluor. Light .90 Amps.
Lounge O/H Fluorescent Light 3.40
3 Bulb Dinette O/H Light 3.30
"Fantastic" Fan 0.00
TV Booster 0.00
Total 8.50 Amps.

Circuit 7, 20 Amp. Fuse, Red
Furnace 6.50 Amps.
(9) Compartment Lights 9.00
Total 15.50 Amps.

LET	DATE	E C A	REVISION RECORD	BY	OK

Circuit 8, 20 Amp. Fuse, Black
Galley O/H Fluorescent Light .90 Amps
#1's 1,2,3, & 4 Ceiling Fluor. Lights 6.30
C/S Wardrobe Light .70
Shower Fan 1.10
Total 9.50 Amps.

Circuit 9, 20 Amp. Fuse, Green
Range Vent & Light 3.20 Amps.
Water Pump 7.00
Oven Light 1.00
Total 11.20 Amps.

Circuit 17, 25 Amp. Fuse, Pink
(5) Docking Lights 20.00 Amps.
Battery Charger 3.00 Amps.
Total Amp. Draw 124.92 Amps.

1st 20 Amps. @ 100% = 20.00 Amps.
2nd 20 Amps. @ 50% = 10.00 Amps.
84.92 Amps. @ 25% = 21.23 Amps.
51.23 Amps.

51.23 Amp. power converter required by calculation. Todd 75 Amp. converter used.
All appliances installed per manufacturers instructions per NEC 551-10 (e-3). All wire is stranded copper, listed THHN or TEW.

ITEM	PART NUMBER	DESCRIPTION	QTY																												
<table border="1"> <tr> <td>TOLERANCES (except as noted)</td> <td colspan="3">AIRSTREAM</td> </tr> <tr> <td>DECIMAL</td> <td>PRODUCT LINE</td> <td>DIVISION</td> <td>Engineering</td> </tr> <tr> <td>FRACTIONAL</td> <td>33' Land Yacht</td> <td>SCALE</td> <td>DRAWN BY TJC</td> </tr> <tr> <td></td> <td>TITLE</td> <td>APPROVED BY</td> <td></td> </tr> <tr> <td></td> <td>12V Calculations</td> <td></td> <td></td> </tr> <tr> <td>ANGULAR</td> <td>NEXT ASSY</td> <td>DATE</td> <td>DRAWING NUMBER</td> </tr> <tr> <td></td> <td></td> <td>9/93</td> <td></td> </tr> </table>				TOLERANCES (except as noted)	AIRSTREAM			DECIMAL	PRODUCT LINE	DIVISION	Engineering	FRACTIONAL	33' Land Yacht	SCALE	DRAWN BY TJC		TITLE	APPROVED BY			12V Calculations			ANGULAR	NEXT ASSY	DATE	DRAWING NUMBER			9/93	
TOLERANCES (except as noted)	AIRSTREAM																														
DECIMAL	PRODUCT LINE	DIVISION	Engineering																												
FRACTIONAL	33' Land Yacht	SCALE	DRAWN BY TJC																												
	TITLE	APPROVED BY																													
	12V Calculations																														
ANGULAR	NEXT ASSY	DATE	DRAWING NUMBER																												
		9/93																													

12 VOLT FUSE PANEL CHEVROLET

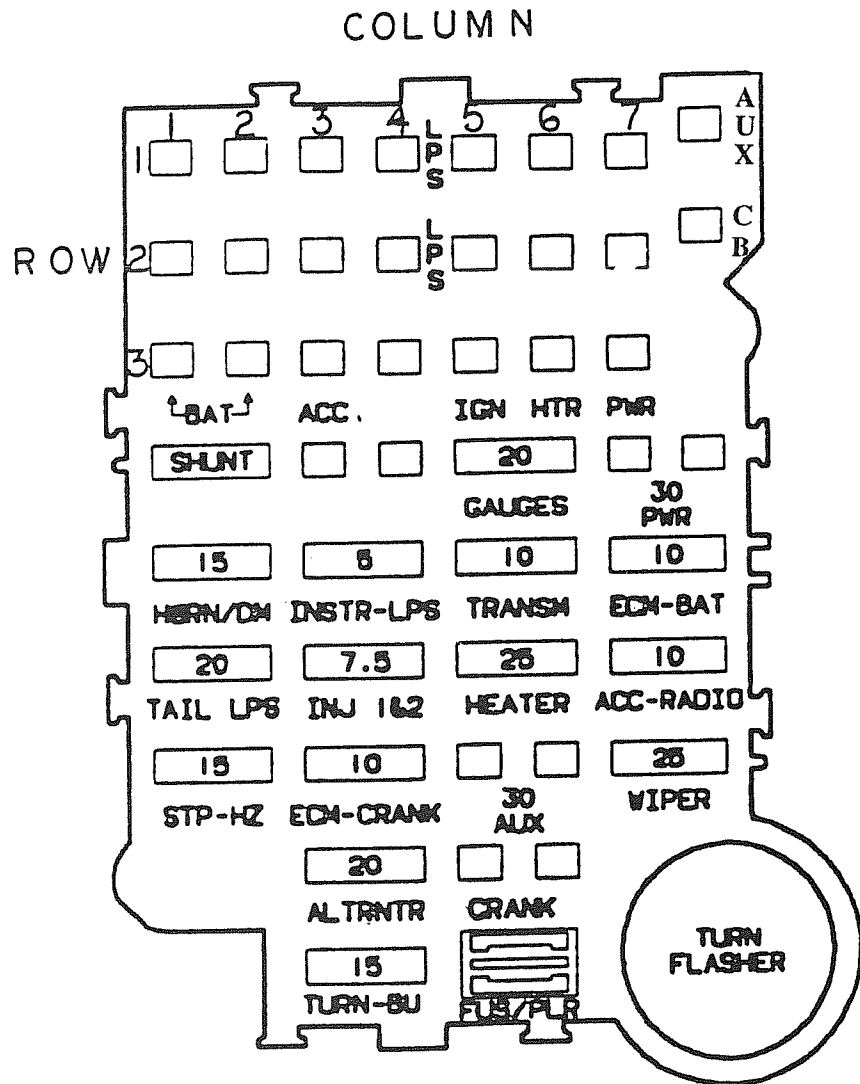

CONN COLOR	LOCATION	FUSE NAME	FUSE SIZE	PROTECTED FUNCTION	WIRE
BLACK	ROW 2 COL. 1	HORN/DM	15	BATTERY LEVEL	14 ORANGE
BLACK	ROW 2 COL. 1	HORN/DM	15	HOOD LT. & VISOR LT.	16 BLUE
BLACK	ROW 3 COL. 1	HORN/DM	15	DOOR LOCK	14 BLK/WHT
CLEAR	ROW 1 COL. 3	ACC-RADIO	10	TV CUTOUT RELAY	14 RED
CLEAR	ROW 2 COL. 3	ACC-RADIO	10	REAR MONITOR	14 YELLOW
CLEAR	ROW 3 COL. 3	ACC-RADIO	10	STEP (IGNITION)	16 RED
BLUE	ROW 1 COL. 4	INSTR.-LPS.	5	INSTR.-PANEL LTS.	16 GRAY
BROWN	ROW 1 COL. 5	GAUGES	20	DRIVING LIGHTS	14 BLUE
BROWN	ROW 2 COL. 5	GAUGES	20	POWER MIRRORS	14 ORANGE/BLK
GREEN	ROW 1 COL. 6	HEATER	25	REAR HEATER	12 BLUE
GREEN	ROW 2 COL. 6	HEATER	25	HEATER & A/C FAN LOW & MEDIUM SPEED	12 BLACK
RED	ROW 1 COL. 7	PWR.	30	DOCKING LIGHT	10 PINK
RED	ROW 2 COL. 7	PWR.	30	PWR. SEATS & WINDOWS	12 RED
RED	ROW 3 COL. 7	PWR.	30	LIGHTERS	12 ORANGE

FIREWALL HARNESS (AUX. HEAT,PWR. SEAT,COMP. LOCK WIRING)

FRONT

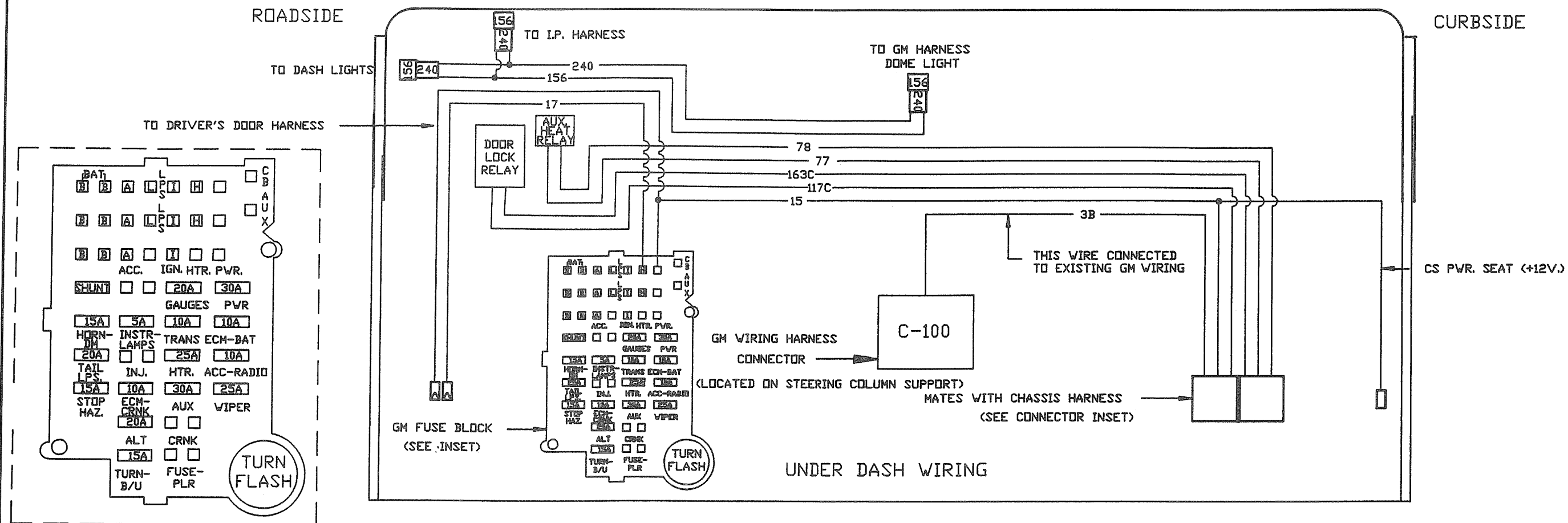

No.	Ga.	Color	Cutting Length	Function	No.	Ga.	Color	Cutting Length	Function
05	18	ORANGE		AUTO BAT. LEVEL	156	16	GREEN		DOME LT. GROUND
08	16	GRAY		I.P. L.T.S.	171	14	BLACK/VHT.		+12V. DOOR LOCK
3	12	ORANGE		CTG. LIGHTERS	240	16	ORANGE		DOME LT. POWER
4	12	BROWN		+12V.	13	12	BLUE		+12V. AUX. HEATER
14	14	BLUE		+12V.(DRIVE L.T.S.)	77	12	RED		AUX. HEAT (L.D.)
15	12	RED		+12V. SEATS/WIND.	77S	12	RED/DRNG.		AUX. HEAT SV.(L.D.)
17	14	ORANGE		MIRRORS	78	12	ORANGE		AUX. HEAT CHD
18	14	YELLOW		MONITOR/JACKS	78S	12	DRNG/VHT.		AUX. HEAT SV.CHD
19	14	BROWN		CLEARANCE L.T.S.	117C	14	PINK		DOOR LOCK (SV.)
20	14	BLUE/VHT.		DRIVE L.T. RELAY	163	16	RED/DRNG.		DOOR UNLOCK
22	14	RED		+12V. IGN.	163C	16	PURPLE		COMP.UNLCK(SV.)
28	12	PURPLE		DOCK L.T.S.	CP	10	RED		+12V. AIR COMP.
29	14	YELLOW		AUX. START SOL.	3B	14	YEL./RED		CENTER BRAKE L.T.
30	14	PURPLE		TV					
34	16	BLUE		HOOD/VISOR L.T.					
36	14	RED		DRIVE L.T. PWR.					
39A	10	RED		+12V. STEP					
39C	16	RED		+12V. STEP (IGN)					
117	16	PNK/BLK.		ALL DOOR LOCK					
163	16	RED/DRNG.		DOOR UNLOCK					

Terminals	
	Bullet .180 Male
	Bullet .180 Female
	Butt Connector
	Ring .250 I.D.
	Spade .250 Female
	Spade .250 Male
	Coax Connector

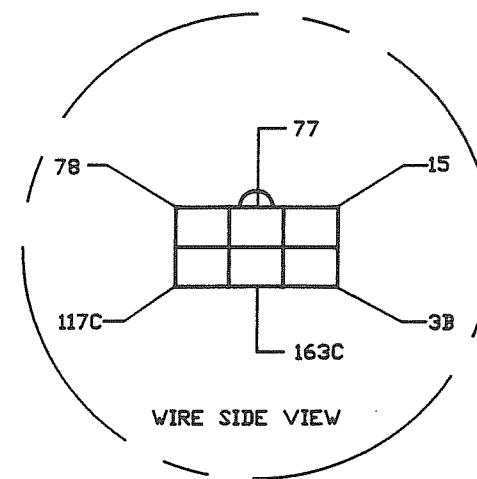

ITEM	PART NUMBER	DESCRIPTION	QTY
TELEGRAPHED	Airstream		DRAWN BY
REXT ASSY			RLA
PRODUCT LINE L/Y-LEG-A/S MFS.			APPROVED BY
TITLE 12V. LAYOUT-FIREWALL			
SCALE	DATE	DRAWING NUMBER	REV.
1=4	09/92	511012L1	D

FIREWALL HARNESS (AUX. HEAT,PWR. SEAT,COMP. LOCK WIRING)

FRONT

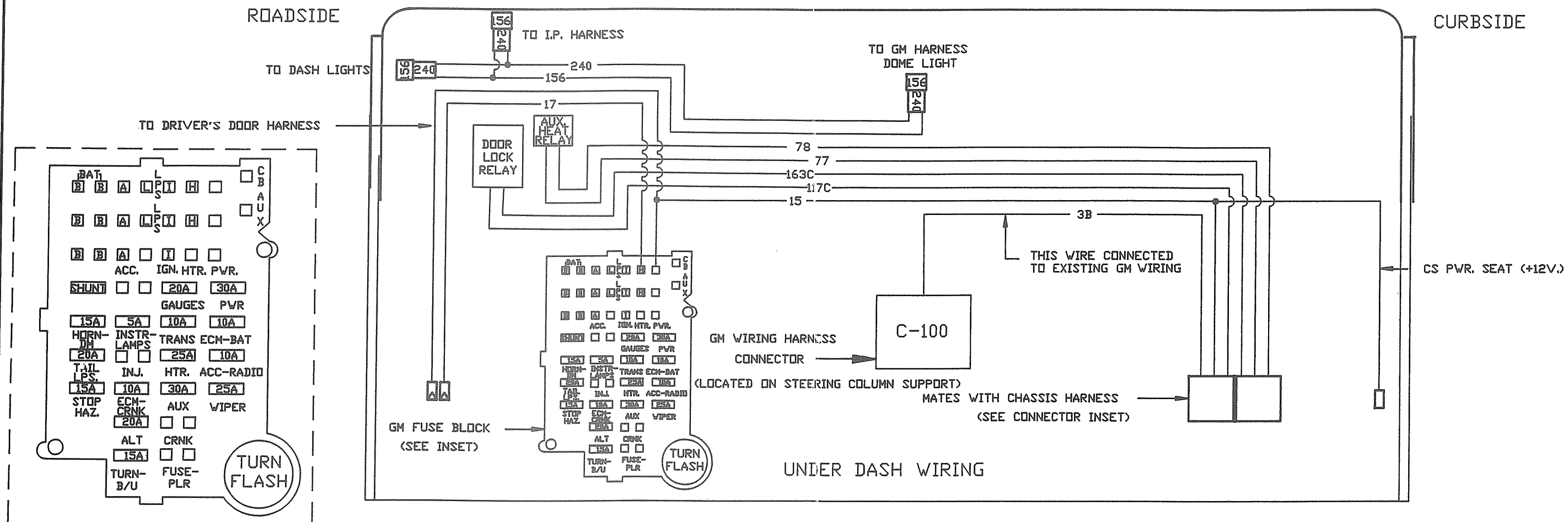

No.	Qty	Color	Cutting Length	Function	No.	Qty	Color	Cutting Length	Function
05	18	ORANGE	■	AUTO BAT. LEVEL	156	16	GREEN	■	DOME LT. GROUND
08	16	GRAY	■	I.P. L.T.S.	171	14	BLACK/VHT.	■	+12V. DOOR LOCK
3	12	ORANGE	■	CIG. LIGHTERS	240	16	ORANGE	■	DOME LT. POWER
4	12	BROWN	■	+12V.	13	12	BLUE	■	+12V. AUX. HEATER
14	14	BLUE	■	+12V.(DRIVE L.T.S)	77	12	RED	■	AUX. HEAT (LD)
15	12	RED	■	+12V. SEATS/WIND	77S	12	RED/DRNG.	■	AUX. HEAT SW.(LD)
17	14	ORANGE	■	MIRRORS	78	12	ORANGE	■	AUX. HEAT (HD)
18	14	YELLOW	■	MONITOR/JACKS	78S	12	DRNG/VHT.	■	AUX. HEAT SW.(HD)
19	14	BROWN	■	CLEARANCE L.T.S.	117C	14	PINK	■	DOOR LOCK (SW.)
20	14	BLUE/VHT.	■	DRIVE L.T. RELAY	163	16	RED/DRNG.	■	DOOR UNLOCK
22	14	RED	■	+12V. IGN.	163C	16	PURPLE	■	COMP.UNLOCK(SW.)
28	12	PURPLE	■	DOCK L.T.S.	CP	10	RED	■	+12V. AIR COMP.
29	14	YELLOW	■	AUX. START SOL.	3B	14	YEL./RED	■	CENTER BRAKE L.T.
30	14	PURPLE	■	TV					
34	16	BLUE	■	HOOD/VISOR L.T.					
36	14	RED	■	DRIVE L.T. PWR.					
39A	10	RED	■	+12V. STOP					
39C	16	RED	■	+12V. STOP (IGN)					
117	16	PINK/BLK.	■	ALL DOOR LOCK					
163	16	RED/DRNG.	■	DOOR UNLOCK					

Terminals

- Bullet .180 Male
- Bullet .180 Female
- Butt Connector
- Ring .250 I.D.
- Spade .250 Female
- Spade .250 Male
- Coax Connector

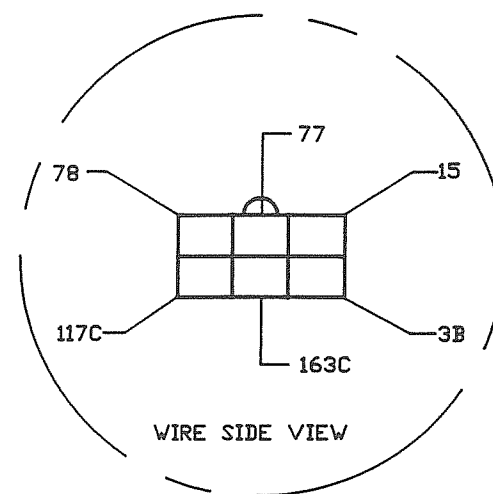

ITEM	PART NUMBER	DESCRIPTION	QTY
TOLERANCES		Airstream	DRAWN BY RLA
±			APPROVED BY
NEXT ASS'Y		PRODUCT LINE L/Y-LEG-A/S MP'S.	
TITLE 12V. LAYOUT-FIREWALL			
SCALE 1=4	DATE 09/92	DRAWING NUMBER 511012L1	REV. D

FIREWALL HARNESS (STEP,KEYLESS ENTRY,CONTROL PANEL WIRING)

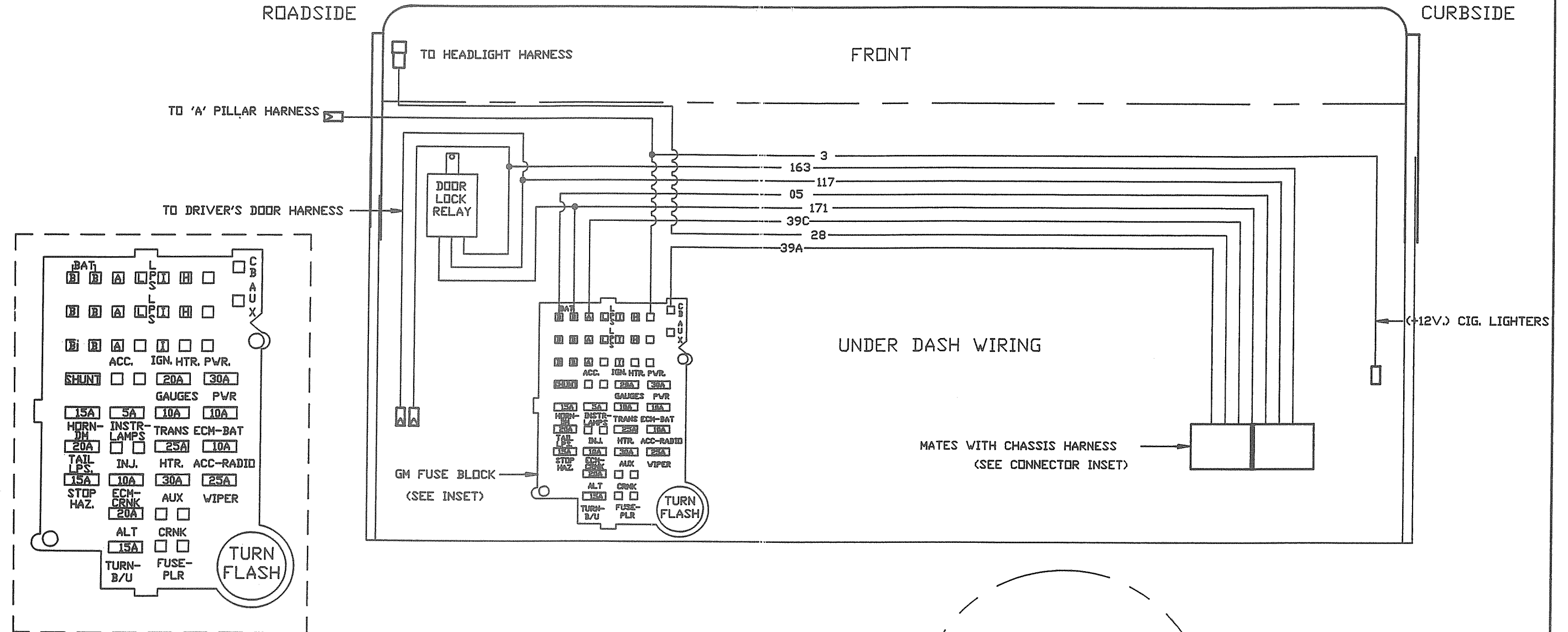

No.	Ga.	Color	Cutting Length	Function	No.	Ga.	Color	Cutting Length	Function
05	18	ORANGE	■	AUTO BAT. LEVEL	156	16	GREEN	■	DOOR LT. GROUND
08	16	GRAY	■	1P. L.T.S.	171	14	BLACK/VHT.	■	+12V. DOOR LOCK
3	12	ORANGE	■	CIG. LIGHTERS	240	16	ORANGE	■	DOOR LT. PWR.
4	12	BROWN	■	+12V.	13	12	BLUE	■	+12V. AUX. HEATER
14	14	BLUE	■	+12V.(DRIVE L.T.S.)	77	12	RED	■	AUX. HEAT (LD)
15	12	RED	■	+12V. SEATS/WIND.	77S	12	RED/DRNG.	■	AUX. HEAT SV.(LD)
17	14	ORANGE	■	MIRRORS	78	12	ORANGE	■	AUX. HEAT (HD)
18	14	YELLOW	■	MONITOR/JACKS	78S	12	DRNG/VHT.	■	AUX. HEAT SV.(HD)
19	14	BROWN	■	CLEARANCE L.T.S.	117C	14	PINK	■	DOOR LOCK (SV.)
20	14	BLUE/VHT.	■	DRIVE LT. RELAY	163C	16	PURPLE	■	COMP.LN.LOCK(SV)
22	14	RED	■	+12V. IGN.	CP	10	RED	■	+12V. AIR COMP.
28	12	PURPLE	■	DOCK L.T.S.	3B	14	YEL/RED	■	CENTER BRAKE L.T.
29	14	YELLOW	■	AUX. START SCL.					
30	14	PURPLE	■	TV					
34	16	BLUE	■	HOOD/VISOR L.T.					
36	14	RED	■	DRIVE LT. PWR.					
39A	10	RED	■	+12V. STEP					
39C	16	RED	■	+12V. STEP (IGN.)					
117	16	PINK/BLK.	■	ALL DOOR LOCK					
163	16	RED/DRNG.	■	DOOR UNL. LOCK					

Terminals	
	Bullet .180 Male
	Bullet .180 Female
	Butt Connector
	Ring .250 I.D.
	Spade .250 Female
	Spade .250 Male
	Coax Connector

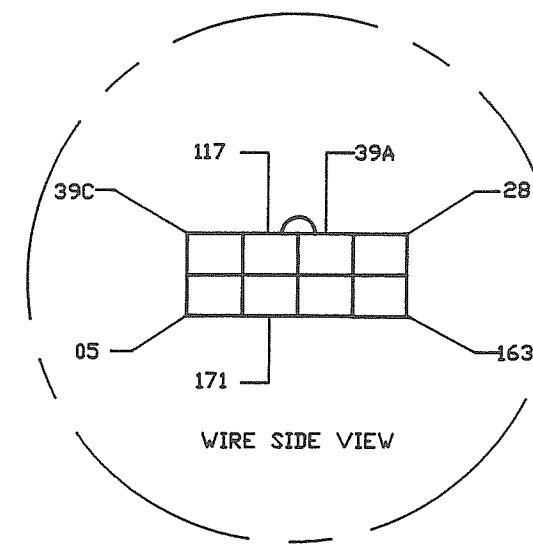

ITEM	PART NUMBER	DESCRIPTION	QTY
TOLERANCES	Airstream PRODUCT LINE L/Y-LEG-A/S MH'S.		DRAWN BY RLA
NEXT ASSY			APPROVED BY
TITLE 12V. LAYOUT-FIREWALL			
SCALE 1=4	DATE 09/92	DRAWING NUMBER 511012L2	REV. D

FIREWALL HARNESS (AUX. HEAT, AUX. START, I.P. LT. WIRING)

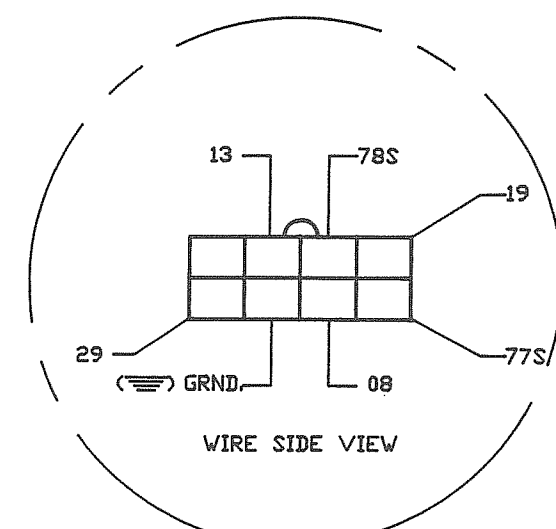
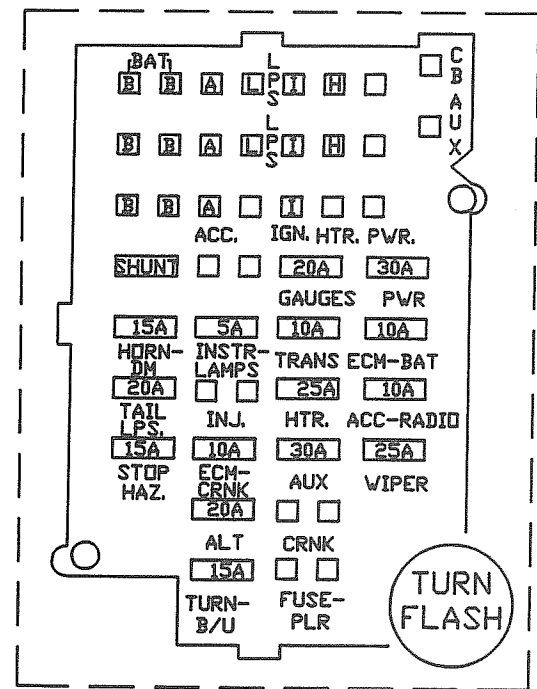
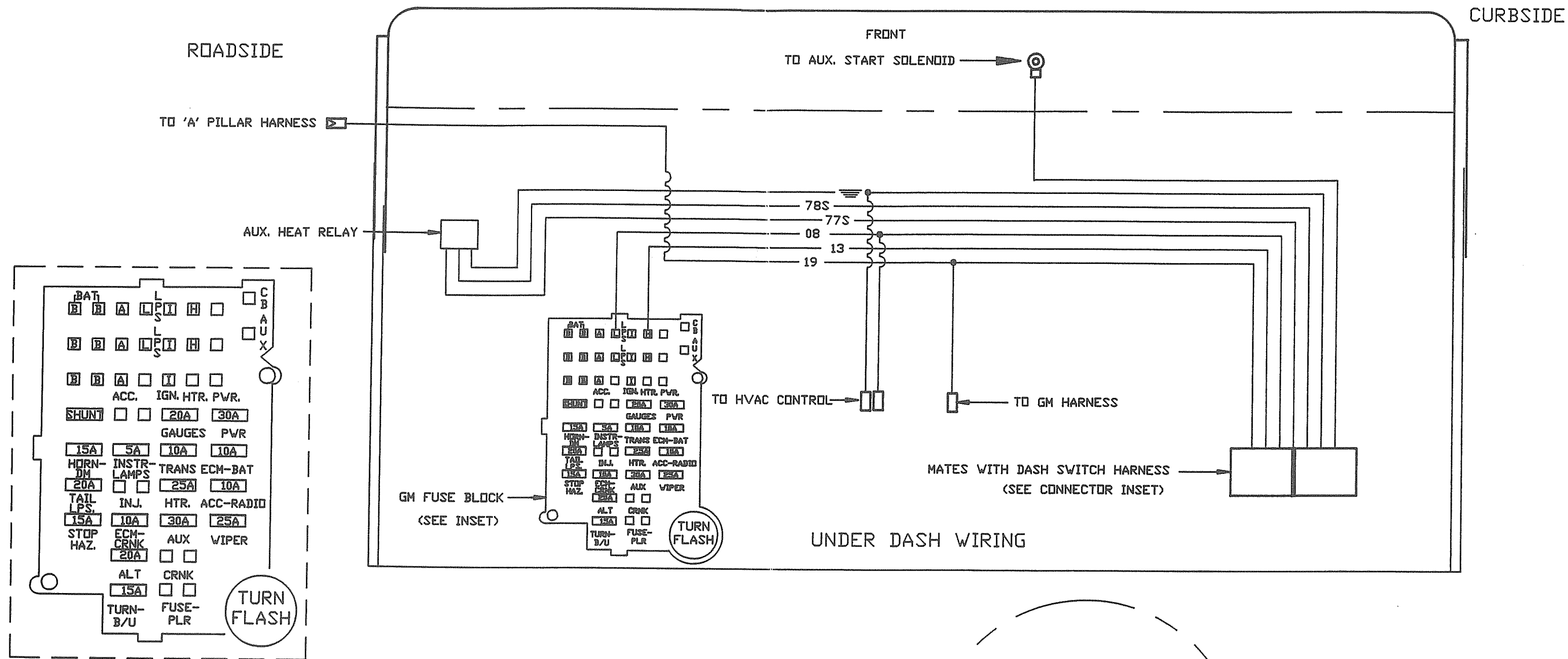

No.	Ga.	Color	Cutting Length	Function	No.	Ga.	Color	Cutting Length	Function
05	18	ORANGE	■	AUTO BAT. LEVEL	156	16	GREEN	■	DOVE LT. GROUND
08	16	GRAY	■	I.P. L.T.S.	171	14	BLACK/WHT.	■	+12V. DOOR LOCK
3	12	ORANGE	■	CIG. LIGHTERS	249	16	ORANGE	■	DOVE LT. POWER
4	12	BROWN	■	+12V.	13	12	BLUE	■	+12V. AUX. HEATER
14	14	BLUE	■	+12V. (DRIVE L.T.S)	77	12	RED	■	AUX. HEAT (LD)
15	12	RED	■	+12V. SEATS/WIND	77S	12	RED/DRNG.	■	AUX. HEAT SV.(LD)
17	14	ORANGE	■	MIRRORS	78	12	ORANGE	■	AUX. HEAT (HD)
18	14	YELLOW	■	MONITOR/JACKS	78S	12	DRNG./VHT.	■	AUX. HEAT SV.(HD)
19	14	BROWN	■	CLEARANCE L.T.S.	117C	14	PINK	■	DOOR LOCK (SW.)
20	14	BLUE/WHT.	■	DRIVE L.T. RELAY	163	16	RED/DRNG.	■	DOOR UNLOCK
22	14	RED	■	+12V. IGN.	163C	16	PURPLE	■	COMP.UNLOCK(SV.)
28	12	PURPLE	■	DOCK L.T.S.	CP	10	RED	■	+12V. AIR COMP.
29	14	YELLOW	■	AUX. START SOL.	39	14	YEL./RED	■	CENTER BRAKE L.T.
30	14	PURPLE	■	TV					
34	16	BLUE	■	HOOD/VISOR L.T.					
36	14	RED	■	DRIVE L.T. PWR.					
39A	10	RED	■	+12V. STEP					
39C	16	RED	■	+12V. STEP (IGN)					
117	16	PINK/BLK.	■	ALL DOOR LOCK					
163	16	RED/DRNG.	■	DOOR UNLOCK					

- Terminals**
- Bullet .180 Male
 - Bullet .180 Female
 - Butt Connector
 - Ring .250 I.D.
 - Spade .250 Female
 - Spade .250 Male
 - Coax Connector

ITEM	PART NUMBER	DESCRIPTION	QTY
TOLERANCES ±		Airstream	DRAWN BY RLA
NEXT ASSY			APPROVED BY
PRODUCT LINE L/Y-LEG-A/S MH'S.			
TITLE 12V. LAYOUT-FIREWALL			
SCALE 1=4	DATE 09/92	DRAWING NUMBER 511012L3	REV. D

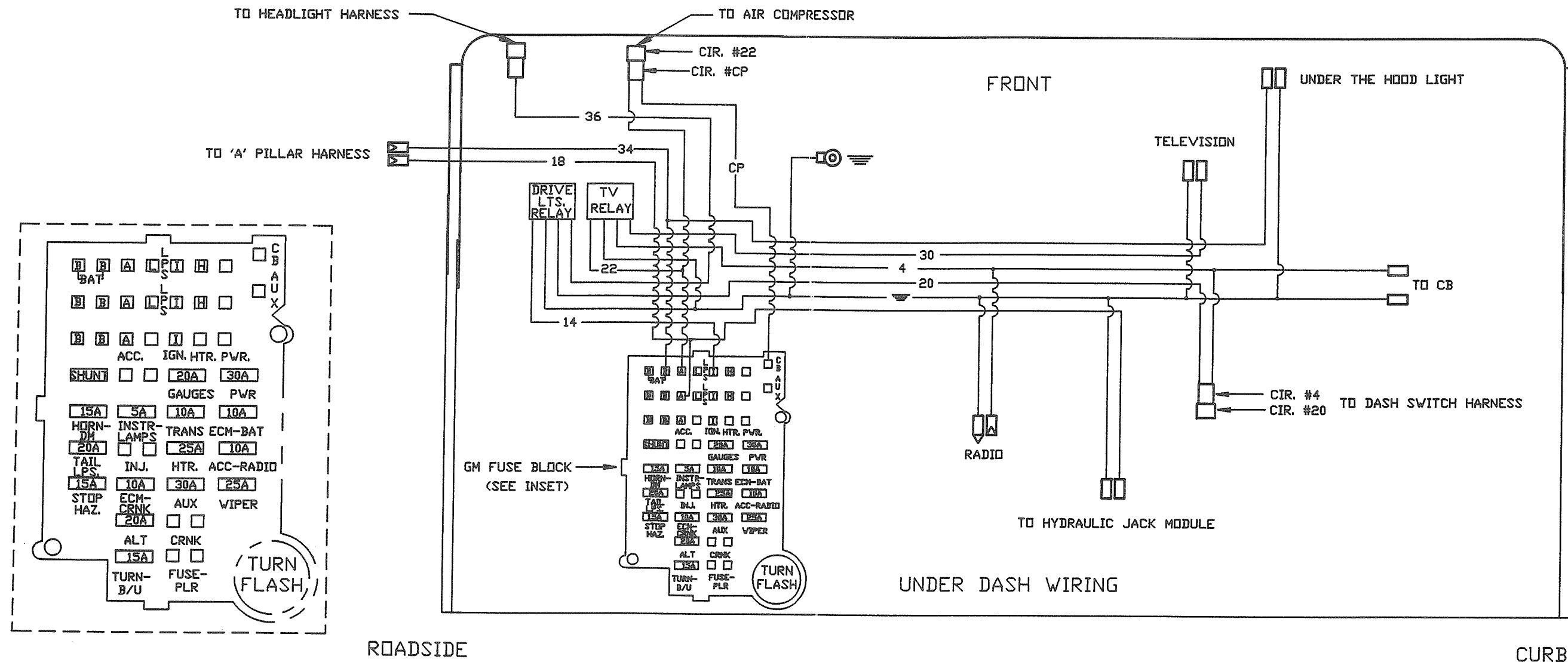

No.	Ga.	Color	Cutting Length	Function	No.	Ga.	Color	Cutting Length	Function
05	18	ORANGE	■	AUTO BAT. LEVEL	156	16	GREEN	■	DDHE LT. GROUND
08	16	GRAY	■	LP. LTS.	171	14	BLACK/WHT.	■	+12V. DOOR LOCK
3	12	ORANGE	■	CIG. LIGHTERS	240	16	ORANGE	■	DDHE LT. PDVER
4	12	BROWN	■	+12V.	13	12	BLUE	■	+12V. AUX. HEATER
14	14	BLUE	■	+12V.(DRIVE LTS)	77	12	RED	■	AUX. HEAT (LD)
15	12	RED	■	+12V. SEATS/WIND	77S	12	RED/DRNG.	■	AUX. HEAT SV.(LD)
17	14	ORANGE	■	MIRRORS	78	12	ORANGE	■	AUX. HEAT (HD)
18	14	YELLOW	■	MONITOR/JACKS	78S	12	DRNG/WHT.	■	AUX. HEAT SV.(HD)
19	14	BROWN	■	CLEARANCE LTS.	117C	14	PINK	■	DOOR LOCK (SV.)
20	14	BLUE/WHT.	■	DRIVE LT. RELAY	163	16	RED/DRNG.	■	DOOR UNLOCK
22	14	RED	■	+12V. IGN.	163C	16	PURPLE	■	COMP.UNLOCK(SV.)
28	12	PURPLE	■	DOCK LTS.	CP	10	RED	■	+12V. AIR COMP.
29	14	YELLOW	■	AUX. START SDL.	3B	14	YEL/RED	■	CENTER BRAKE LT.
30	14	PURPLE	■	TV					
34	16	BLUE	■	HOOD/VISOR LT.					
36	14	RED	■	DRIVE LT. PWR.					
39A	10	RED	■	+12V. STEP					
39C	16	RED	■	+12V. STEP (IGN)					
117	16	PINK/BLK.	■	ALL DOOR LOCK					
163	16	RED/DRNG.	■	DOOR UNLOCK					

Terminals	
	Bullet .180 Male
	Bullet .180 Female
	Butt Connector
	Ring .250 I.D.
	Spade .250 Female
	Spade .250 Male
	Coax Connector

ITEM	PART NUMBER	DESCRIPTION	QTY
TOLERANCES		Airstream	DRAWN BY
±			RLA
NEXT ASSY		PRODUCT LINE L/Y-LEG-A/S M/H'S.	APPROVED BY
TITLE 12V. LAYOUT-FIREWALL			
SCALE	DATE	DRAWING NUMBER	REV.
1=4	09/92	511012L4	D

LET DATE	E.C.N.	REVISION RECORD	BY
9/92	4395	Production Release	RA

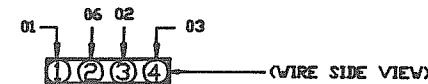
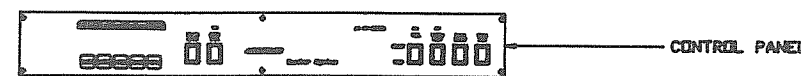
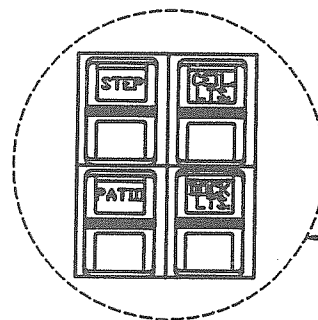
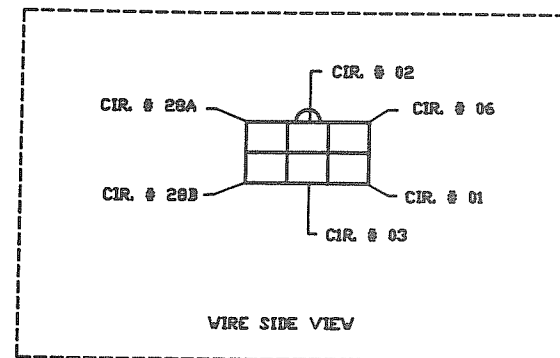

MATES WITH CONNECTOR ON CONTROL PANEL

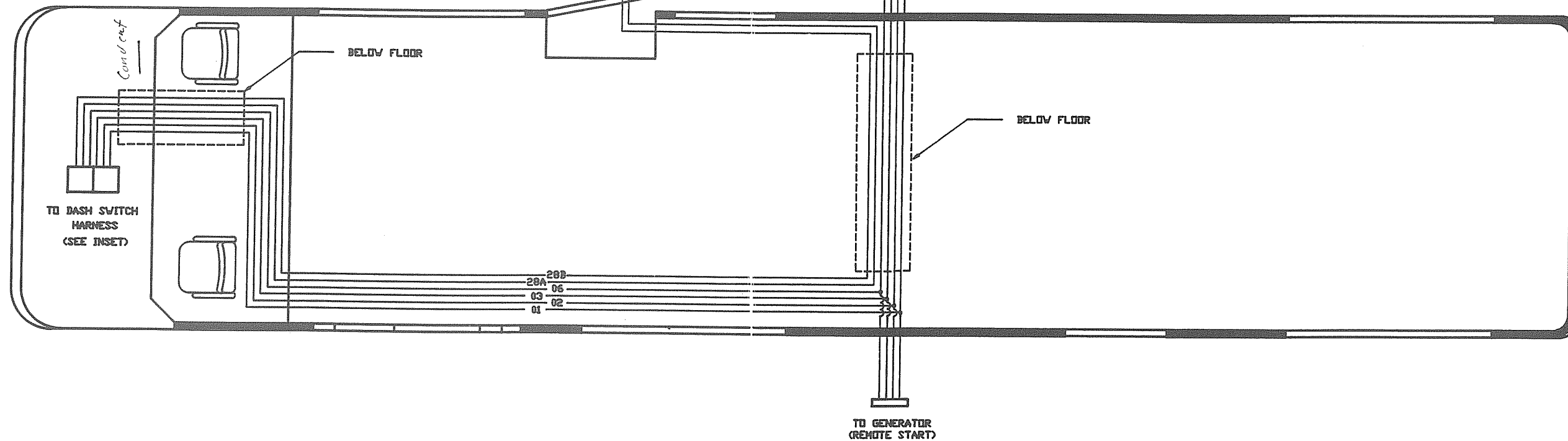

No.	Ga.	Color	Cutting Length	FUNCTION
01	18	BLACK	≡	GEN (GROUND)
02	18	BROWN	≡	GEN (STOP)
03	18	YELLOW	≡	GEN (START)
05	18	ORANGE	≡	BAT COND.(ENG)
06	18	RED	≡	GEN (HOUR METER)
16	12	BLACK	≡	+ 12V
6	12	RED	≡	+ 12V
21	12	GREEN	≡	aisle LT.
28	12	PURPLE	≡	DOCK LT.
30	12	BLUE/WHT.	≡	LPG GAUGE
37	18	BLACK/RED	≡	DOOR LOCK LT.
39A	10	RED	≡	+12V. (STEP)
39B	16	RED/WHT.	≡	STEP SW.
39C	16	RED	≡	+ 12V (STEP-IGN.)
39D	16	RED/WHT.	≡	STEP SW.
39E	16	YELLOW	≡	+ 12V (STEP-IGN.)
15	12	RED	≡	+ 12V.
77	12	RED	≡	AUX. HEAT (LD)
78	12	ORANGE	≡	AUX. HEAT (HD)
≡	≡	≡	≡	≡

No.	Ga.	Color	Cutting Length	FUNCTION
163C	14	PURPLE	≡	COMP. UNLOCK SW.
117	14	PINK/BLK.	≡	COMP. LOCK
117C	14	PINK	≡	COMP. LOCK SW.
118	14	PINK/DRNG.	≡	UNLOCK DRIVE DR.
119	16	PINK/YEL.	≡	LOCK INPUT
120	16	PINK/GRN.	≡	UNLOCK INPUT
163	14	RED/DRNG.	≡	UNLOCK MAIN JIR.
171	14	BLACK/WHT.	≡	+ 12V.
4	12	BROWN	≡	+ 12V.
3B	14	YEL/RED	≡	CNTR. BRAKE LT.
28A	12	PURP/WHT.	≡	DOCK LT. SW.
28B	12	PURP/WHT.	≡	DOCK LT. SW.

ITEM	PART NUMBER	DESCRIPTION	QTY
TOLERANCES	Airstream		DRAWN BY
±			RLA
NEXT ASSY	PRODUCT LINE L.Y.LEG.A.S.M.H.S.		APPROVED BY
TITLE 12V. LAYOUT-CHASSIS			
SCALE	DATE	DRAWING NUMBER	REV.
1=16	09/02/92	511011L1	D

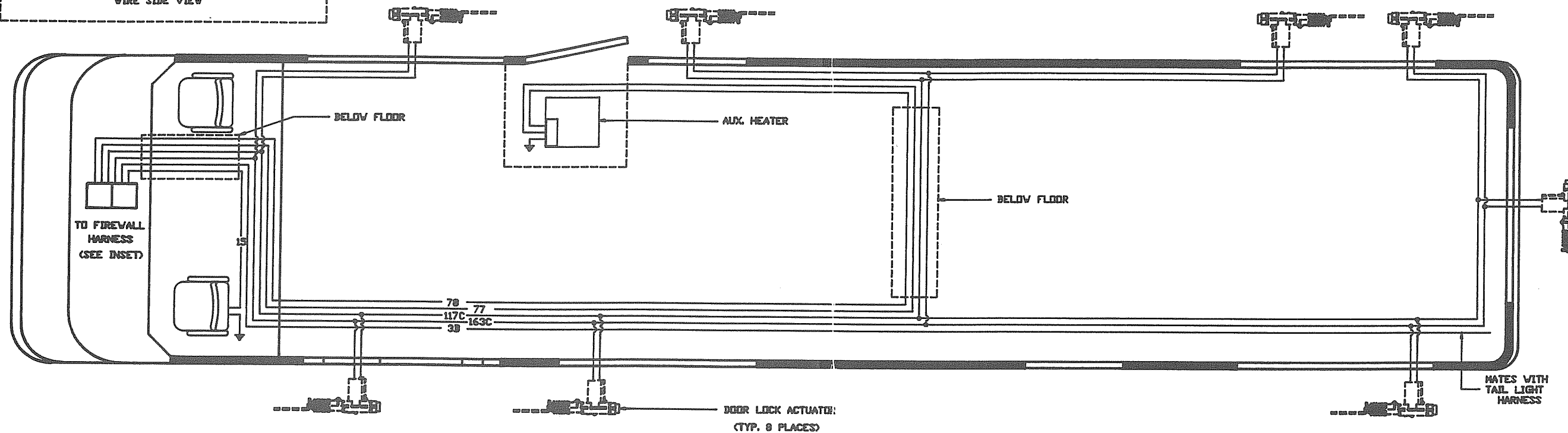
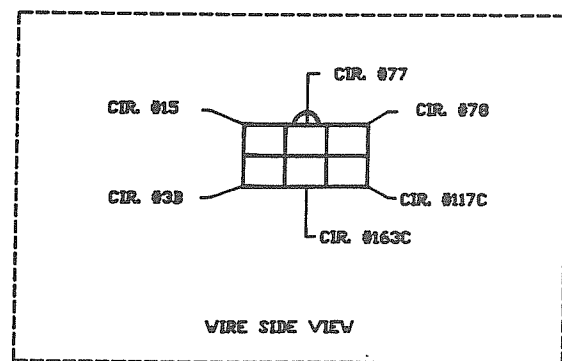

No.	Ga	Color	Cutting Length	FUNCTION
01	18	BLACK	■	GEN (GROUND)
02	18	BROWN	■	GEN (STOP)
03	18	YELLOW	■	GEN (START)
05	18	ORANGE	■	BAT COND.(ENG)
06	18	RED	■	GEN (HOUR METER)
16	12	BLACK	■	+ 12V
6	12	RED	■	+ 12V
21	12	GREEN	■	AISLE LT.
28	12	PURPLE	■	DOCK LT.
30	12	BLUE/WHT.	■	LPG GAUGE
37	18	BLACK/RED	■	DOOR LOCK LT.
39A	10	RED	■	+12V. (STEP)
39B	16	RED/WHT.	■	STEP SW.
39C	16	RED	■	+ 12V (STEP-IGN.)
39D	16	RED/WHT.	■	STEP SW.
39E	16	YELLOW	■	+ 12V (STEP-IGN.)
15	12	RED	■	+ 12V.
77	12	RED	■	AUX. HEAT (LD)
78	12	ORANGE	■	AUX. HEAT (HT)
■	■	■	■	■

No.	Ga	Color	Cutting Length	FUNCTION
163C	14	PURPLE	■	COMP. UNLOCK SV.
117	14	PINK/BLK.	■	COMP. LOCK
117C	14	PINK	■	COMP. LOCK SW.
118	14	PINK/DRNG.	■	UNLOCK DRIVE DR.
119	16	PINK/YEL.	■	LOCK INPUT
120	16	PINK/GRN.	■	UNLOCK INPUT
163	14	RED/DRNG.	■	UNLOCK MAIN DR.
171	14	BLACK/WHT.	■	+ 12V.
4	12	BROWN	■	+ 12V.
38	14	YEL/RED	■	CNTR. BRAKE LT.
28A	12	PURP/WHT.	■	DOCK LT. SW.
28B	12	PURP/WHT.	■	DOCK LT. SW.

ITEM	PART NUMBER	DESCRIPTION	QTY
TOLERANCES ±	Airstream		DRAWN BY RLA
WGT ASS'Y	PRODUCT LINE L.Y.LEG.A.S.M.H.S.		APPROVED BY
TITLE 12V. LAYOUT-CHASSIS			
SCALE 1=16	DATE 08/17/92	DRAWING NUMBER 51101L2	REV. D

CHASSIS HARNESS (DOOR LOCK SW, AISLE LT, DOCK LT. WIRING)

LET DATE	E.C.N.	REVISION RECORD	BY
9/92	4395	Production Release	RA

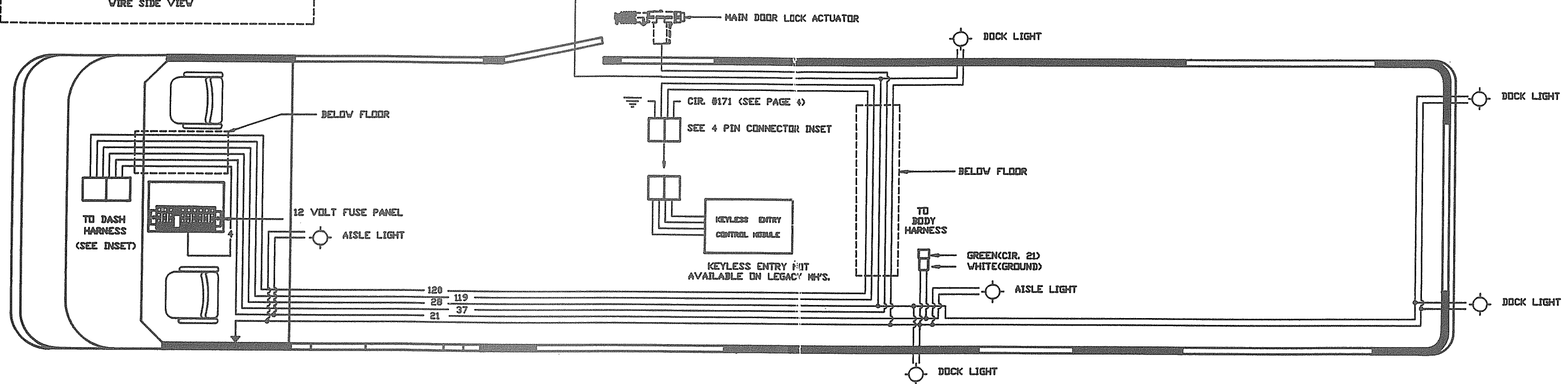
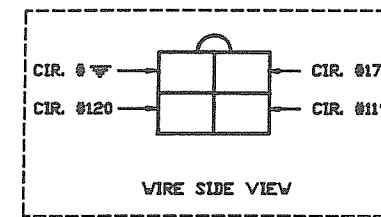
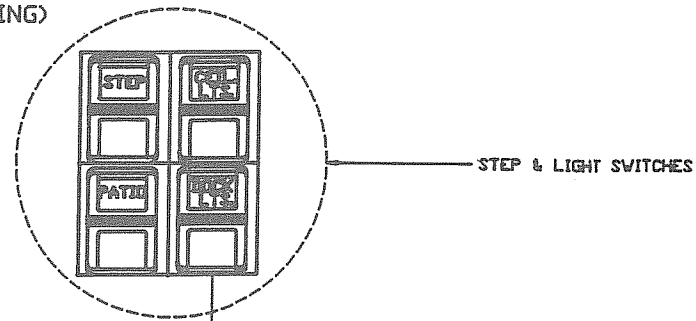
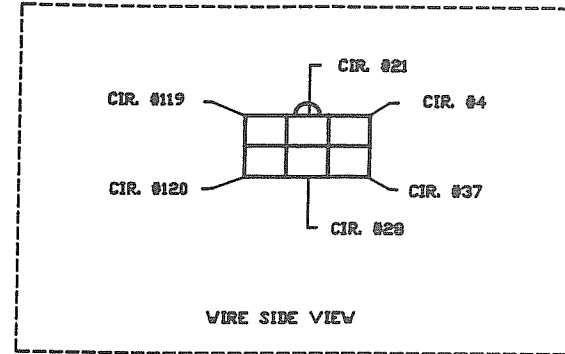

No.	Ga.	Color	Cutting Length	FUNCTION
01	18	BLACK	■	GEN (GROUND)
02	18	BROWN	■	GEN (STOP)
03	18	YELLOW	■	GEN (START)
05	18	ORANGE	■	BAT COND.(ENG)
06	18	RED	■	GEN (HOUR METER)
16	12	BLACK	■	+ 12V
6	12	RED	■	+ 12V
21	12	GREEN	■	AISLE LT.
28	12	PURPLE	■	DOCK LT.
30	12	BLUE/WHT.	■	LPG GAUGE
37	18	BLACK/RED	■	DOOR LOCK LT.
39A	10	RED	■	+12V. (STEP)
39B	16	RED/WHT.	■	STEP SV.
39C	16	RED	■	+ 12V (STEP-IGN.)
39D	16	RED/WHT.	■	STEP SV.
39E	16	YELLOW	■	+ 12V (STEP-IGN.)
15	12	RED	■	+ 12V.
77	12	RED	■	AUX. HEAT (LO)
78	12	ORANGE	■	AUX. HEAT (HI)
■	■	■	■	■

No.	Ga.	Color	Cutting Length	FUNCTION
163C	14	PURPLE	■	COMP. UNLOCK SW.
117	14	PINK/BLK.	■	COMP. LOCK
117C	14	PINK	■	COMP. LOCK SW.
118	14	PINK/ORNG.	■	UNLOCK DRIVE DE.
119	16	PINK/YEL.	■	LOCK INPUT
120	16	PINK/GRN.	■	UNLOCK INPUT
163	14	RED/ORNG.	■	UNLOCK MAIN DR.
171	14	BLACK/WHT.	■	+ 12V.
4	12	BROWN	■	+ 12V.
3B	14	YEL/RED	■	CNTR. BRAKE LT.
28A	12	PURP/WHT.	■	DOCK LT. SW.
28B	12	PURP/WHT.	■	DOCK LT. SW.

ITEM	PART NUMBER	DESCRIPTION	QTY
TOLERANCES		Airstream	DRAWN BY
±			RLA
NEXT ASSY		PRODUCT LINE	APPROVED BY
		LY,LEG.A.S.M.H.S.	
TITLE 12V. LAYOUT-CHASSIS			
SCALE	DATE	DRAWING NUMBER	REV.
1=16	08/17/92	511011L3	D

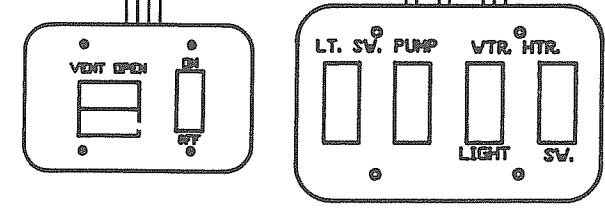
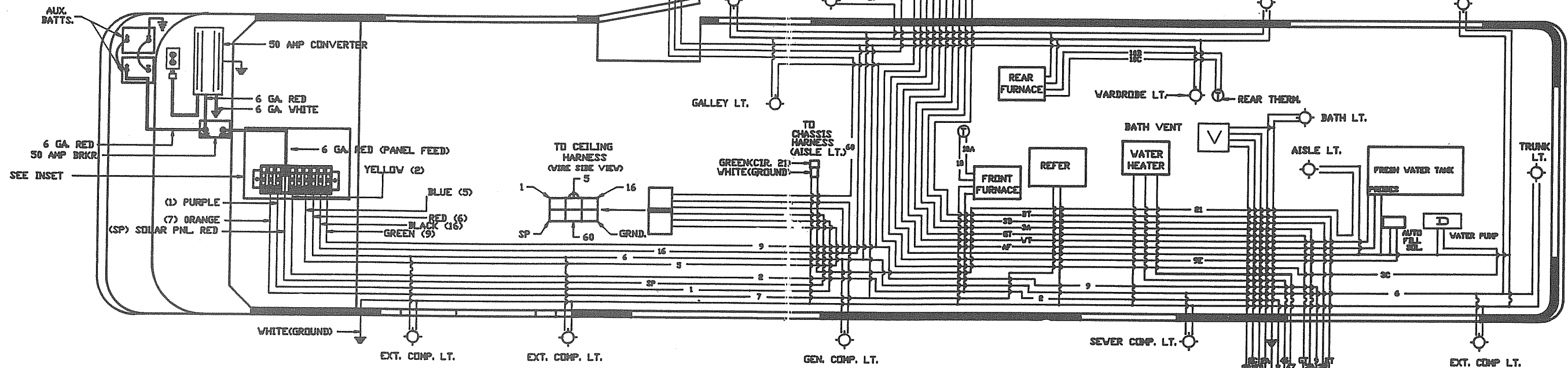
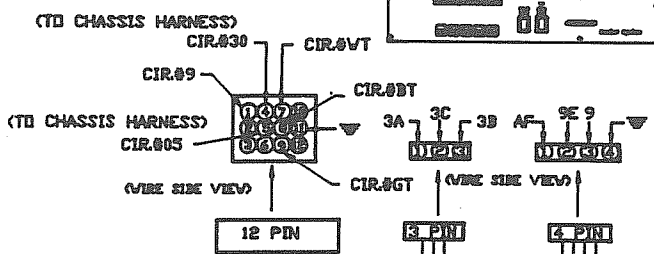
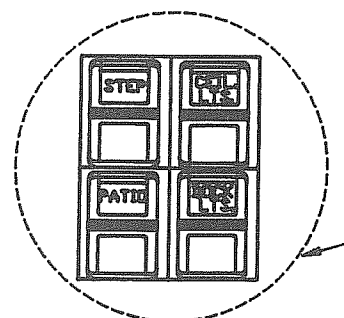
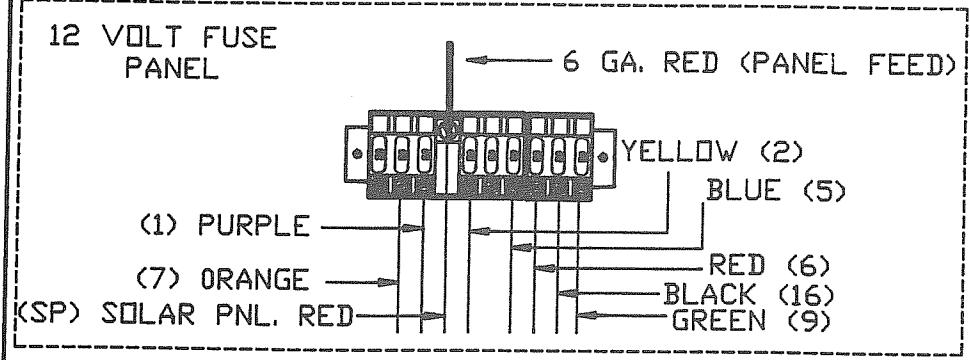

No.	Ga.	Color	Cutting Length	FUNCTION
1	12	PURPLE	■	+ 12V.
2	12	YELLOW	■	+ 12V.
2A	12	RED/YEL.	■	BATH LT.
2B	12	BLUE	■	BATH FAN
2C	12	RED	■	BATH FAN
2D	12	BLACK	■	BATH FAN
3A	12	ORANGE	■	VTR. PUMP SV.
3B	12	ORANGE	■	VTR. PUMP SV.
3C	12	ORNG/WHT.	■	VATER PUMP
16	12	BLACK	■	+ 12V.
5	12	BLUE	■	+ 12V.
6	12	RED	■	+ 12V.
7	8	ORANGE	■	+ 12V.
9	12	GREEN	■	+ 12V.
9E	20	BLUE/YEL.	■	AUTO FILL SOL.
10	18	BLUE/WHT.	■	FRNT. FURN. THERM.
10A	18	BLUE/WHT.	■	FRNT. FURN. THERM.
10B	18	BLUE/WHT.	■	REAR FURN. THERM.
10C	18	BLUE/WHT.	■	REAR FURN. THERM.
21	12	GREEN	■	AISLE L.T.S.

No.	Ga.	Color	Cutting Length	FUNCTION
29	12	BRN/WHT.	■	PATIO LT.
46	12	BROWN	■	VTR. HEATER
47	12	BLUE	■	VTR. HEATER
60	12	BLACK/WHT.	■	CEILING L.T.S.
AF	18	GRAY	■	AUTO FILL SENSE
BT	18	BROWN	■	BLACK TANK
GT	18	GREEN	■	GRAY TANK
VT	18	RED	■	FRESH VTR. TANK
SP	12	RED	■	SOLAR PANEL
■	■	■	■	■

ITEM	PART NUMBER	DESCRIPTION	QTY
TOLERANCES	Airstream		DRAWN BY RLA
NEXT ASSY	PRODUCT LINE L.V. LEG. ASSEMBLY		APPROVED BY
TITLE 12V. LAYOUT-BODY INT.			
SCALE 1=16	DATE 08/17/92	DRAWING NUMBER 511009L	REV. D

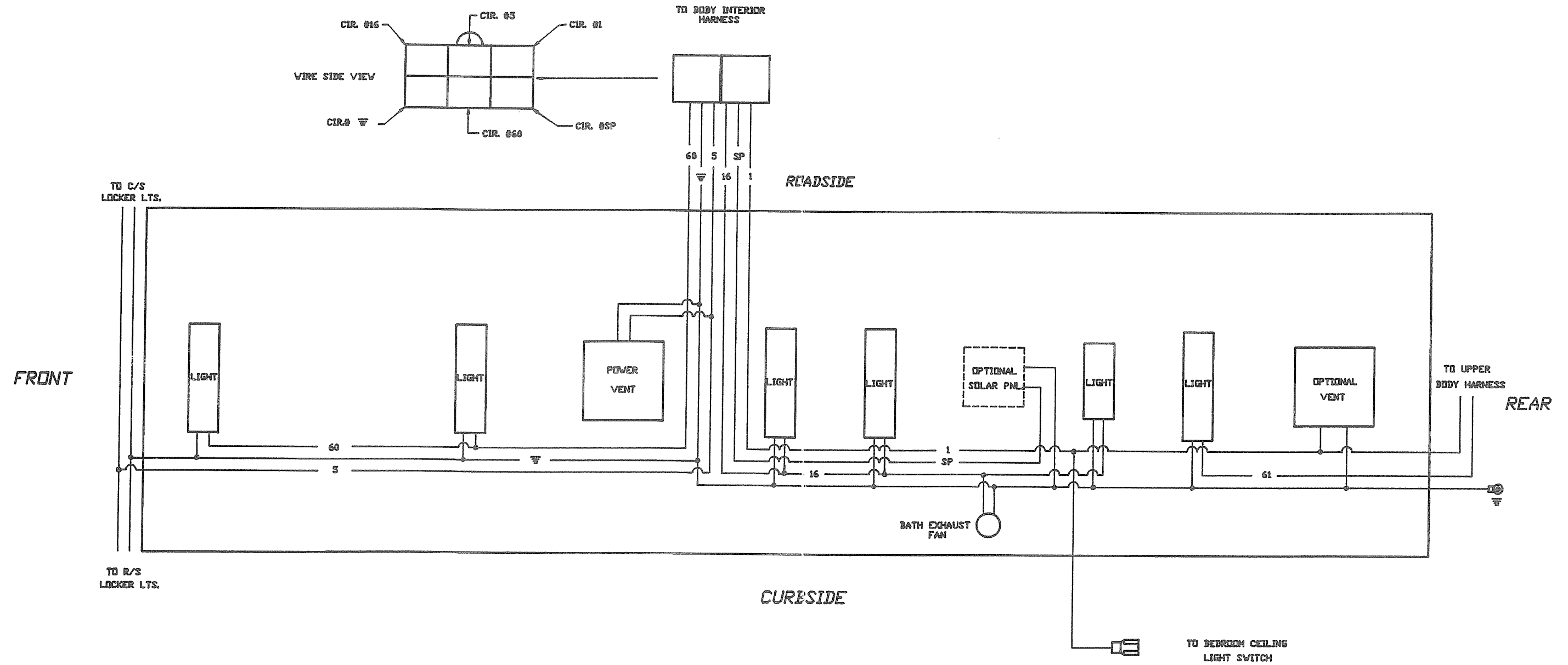

No.	Ga.	Color	Cutting Length	Function
1	12	PURPLE	*	+12V.
16	12	BLACK	*	+12V.
5	12	BLUE	*	+12V.
60	12	BLACK/WHT.	*	CEIL. LTS.(FRONT)
61	12	PURPLE/WHT.	*	BD. RM. CEIL. LT.
SP	12	RED	*	SOLAR PANEL
≡	12	WHITE	*	GROUND
*	*	*	*	*
*	*	*	*	*
*	*	*	*	*

Terminals	
	Bullet .180 Male
	Bullet .180 Female
	Butt Connector
	Ring .250 I.D.
	Spade .250 Female
	Spade .250 Male
	Coax Connector

ITEM	PART NUMBER	DESCRIPTION	QTY
TOLERANCES		Airstream	DRAWN BY <i>AGL/STB</i>
±			
NEXT ASSY		PRODUCT LINE L/Y/LEG. MOTORHOME	
TITLE 12V. LAYOUT-CEILING			
SCALE 1=16	DATE 08-21-92	DRAWING NUMBER 511014L	REV. D

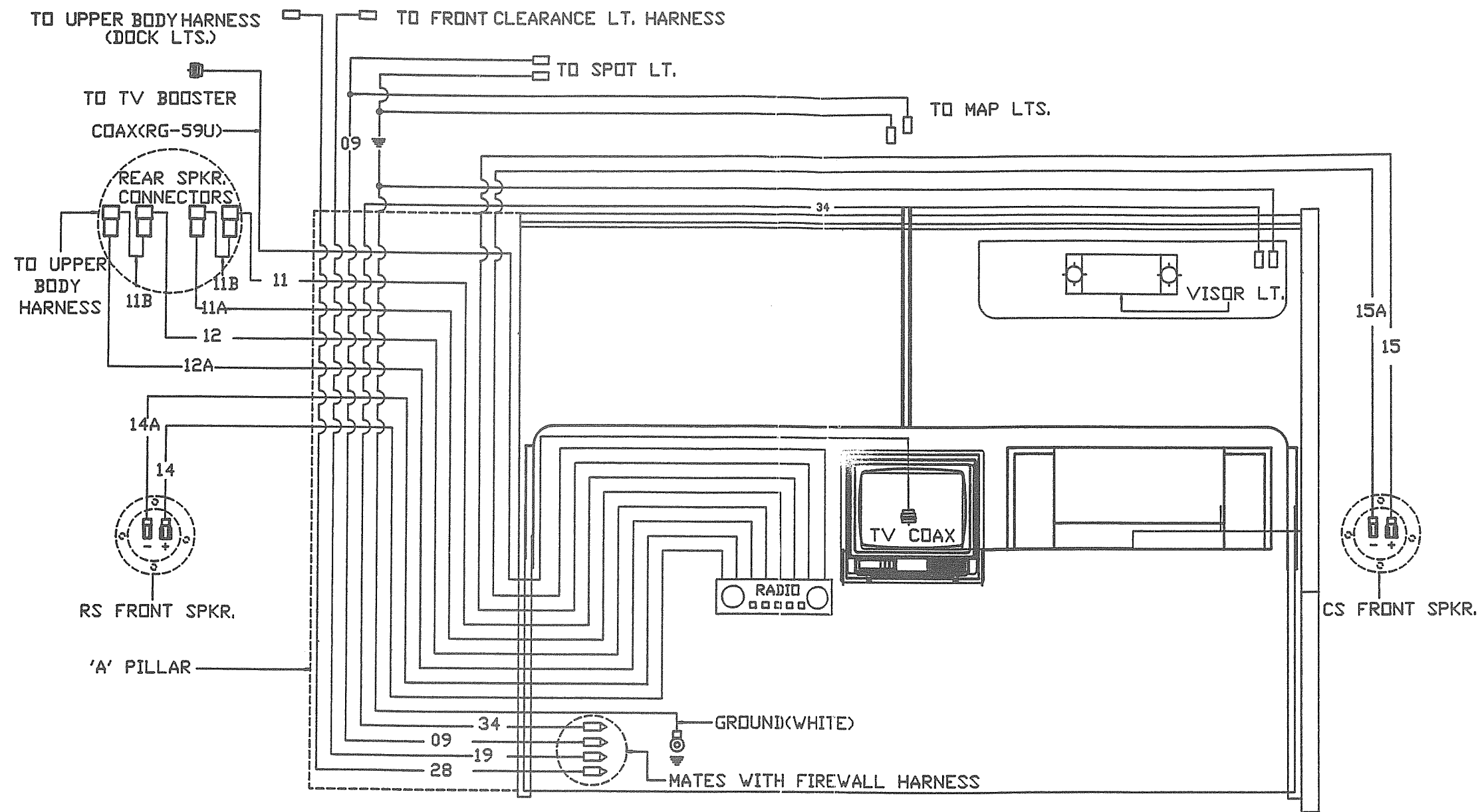

No.	Ga	Color	Cutting Length	Function
09	12	YELLOW	*	SPOT/MAP LTS.
11	18	GRAY	*	LT. SPKR. REAR(+)
11A	18	BLACK	*	LT. SPKR. REAR(-)
11B	18	YELLOW	*	SPEAKER WIRE
12	18	ORANGE	*	RT. SPKR. REAR(+)
12A	18	BLACK/WHT.	*	RT. SPKR. REAR(-)
14	18	BLUE	*	LT. SPKR. FRONT(+)
14A	18	BLACK	*	LT. SPKR. FRONT(-)
15	18	RED	*	RT. SPKR. FRONT(+)
15A	18	BLACK/WHT.	*	RT. SPKR. FRONT(-)

No.	Ga	Color	Cutting Length	Function
18	14	YELLOW	*	MONITOR
19	14	BROWN	*	CLEARANCE LTS.
27	14	BLUE	*	MONITOR
28	12	PURPLE	*	DOCK LTS.
34	16	BLUE	*	VISOR LT.
*	*	*	*	*
*	*	*	*	*
*	*	*	*	*
*	*	*	*	*
*	*	*	*	*

ITEM	PART NUMBER	DESCRIPTION	QTY
TOLERANCES	Airstream		DRAWN BY
NEXT ASSY			RLA
TITLE		PRODUCT LINE	APPROVED BY
SCHEMATIC-12V 'A' POST		L/YLEG. MOTORHOME	
SCALE	DATE	DRAWING NUMBER	REV.
1=4	08/07/92	510941L	D

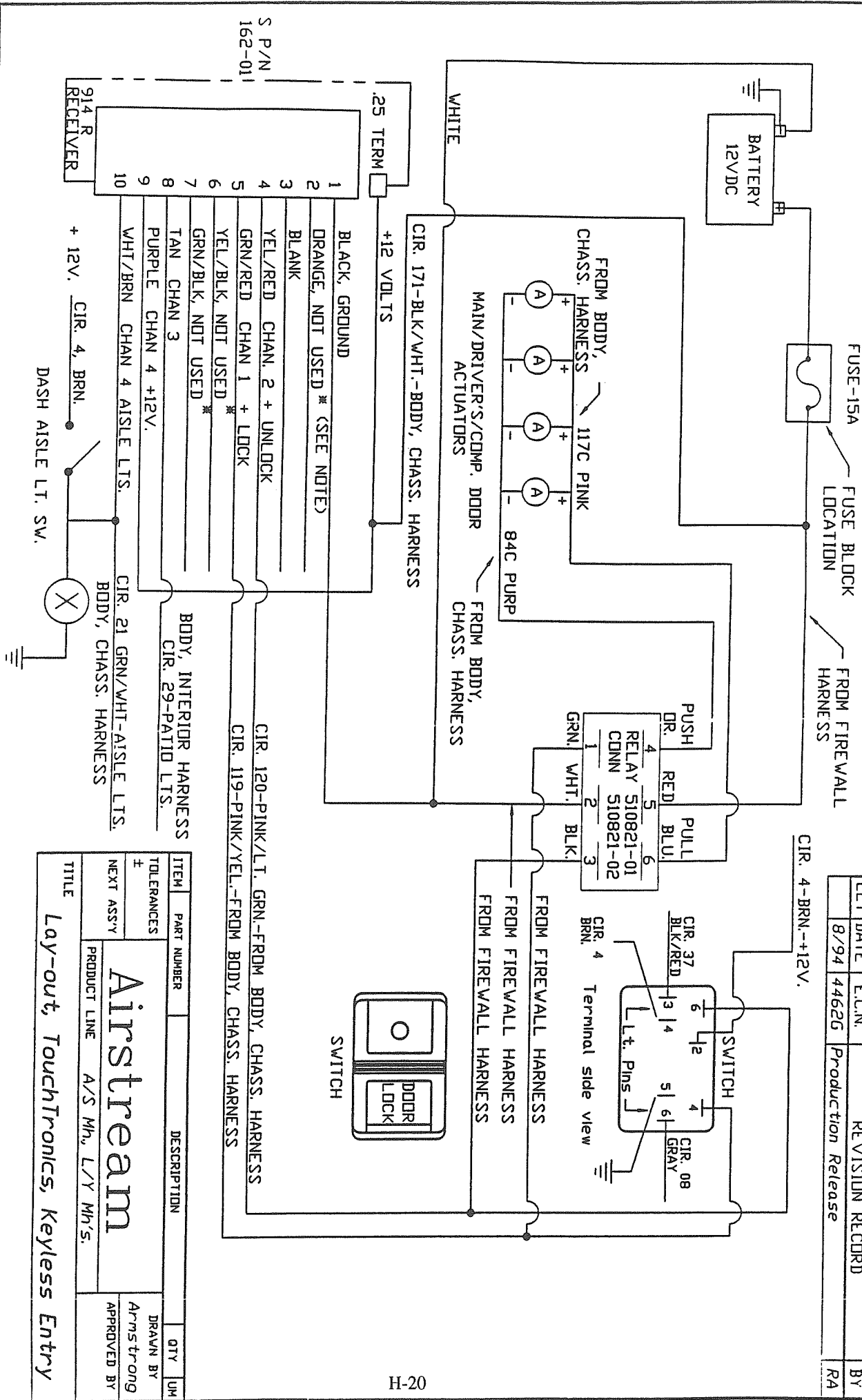

LET	DATE	E.C.N.	REVISION RECORD	BY
	8/94	4462G	Production Release	RA

ITEM	PART NUMBER	DESCRIPTION	QTY	U/M
±		TOLERANCES		
±		NEXT ASSY		
Airstream		PRODUCT LINE	A/S Mh, L/Y Mh'S.	
Lay-out, TouchTronics, Keyless Entry				
DRAWN BY		Airmstrong		
APPROVED BY				

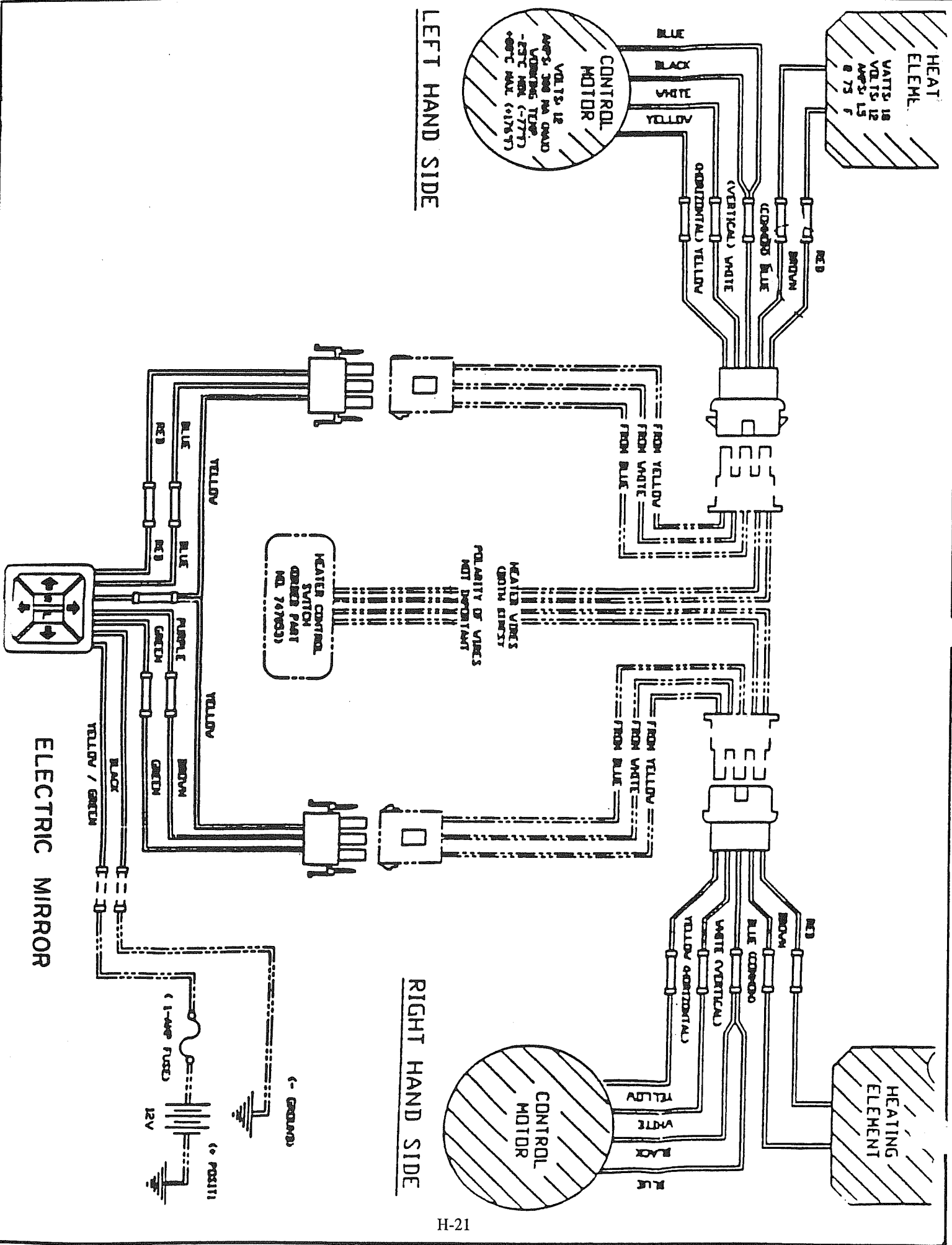

LEFT HAND SIDE

RIGHT HAND SIDE

CONTROL MOTOR
 VOLTS: 12
 AMP'S: 300 MA (MAX)
 WORKING TEMP
 -32°C MIN (-77°F)
 +60°C MAX (115°F)

HEAT ELEMENT
 VOLTS: 18
 VOLTS: 12
 AMP'S: 1.5
 8.75 F

HEATING ELEMENT

HEATER CONTROL SWITCH (ORDER PART NO. 747633)

POLARITY OF WIRES NOT DEPENDANT

ELECTRIC MIRROR

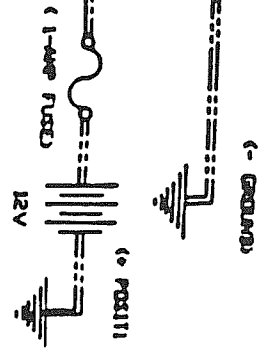

HARNES, WIPER/WASHER

CONNECTOR SIDE

MOTOR SIDE

TO RED
 TO BLUE
 TO BROWN + GREEN
 TO BLACK



TO "F" INSERT INTO POSITION "F" 5



TO "E"
 TO "D"
 TO "C"
 TO "B"

TO WASHER MOTOR
 FEMALE TERMINALS

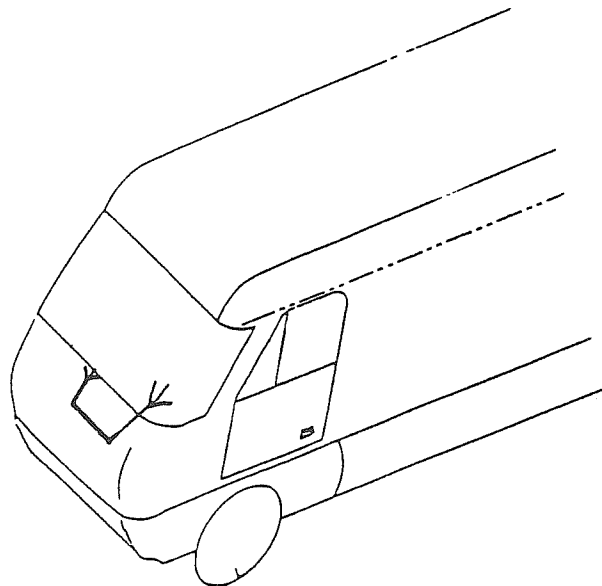

WIRE CHART

Circ.	Ga.	Color
1	14	Red
2	14	Blue
3	14	Green
5	14	Blue/White
6	14	Black
7	12	Black

HARNES, DASH SWITCHES

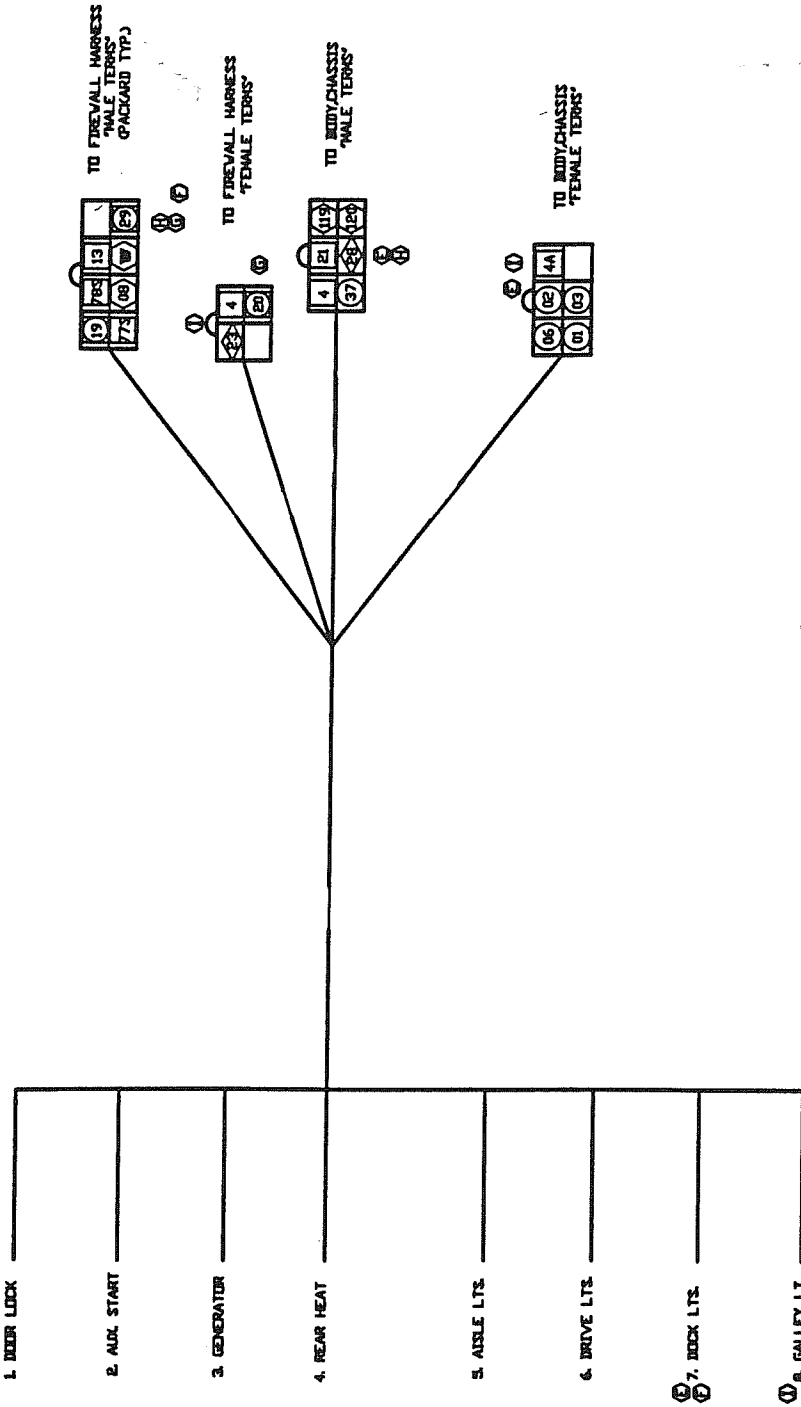

WIRE CHART

Circ.	Ga.	Color	Function
01	18	Black	Gen. (Ground)
02	18	Brown	Gen. (Stop)
03	18	Yellow	Gen. (Start)
06	18	Red	Gen. (Hour meter)
08	16	Gray	I.P. Lts.
4	12	Brown	+12V
13	12	Blue	Aux. Heat. +12V.
19	14	Brown	Clearance Lts.
20	14	Blue/Wht	Drive Lt. Relay
21	12	Grn/Whit.	Aisle Lts.
29	14	Yel/Blk	Aux. Start Sol.
37	18	Blk/Red	Lock Ind. Lt.
119	16	Pink/Yel	Door Lock
120	16	Pink/Lt Grn	Door Unlock
77S	12	Red/Whit	Aux. Heat (Lo)
78S	12	Org/Whit	Aux. Heat (Hi)
28	10	Purple/Yel	Docks Lts.
23	10	pink	+12V.
4A	12	Grn/Blk	Galley Light

SWITCH CONNECTOR CHART

Switch #	2	3	4	6	Lt. Pins 3 & 4		Lt. Pins 5 & 6	
					4	6	4	6
#1	4	#	119	120	37	4	O8	16 White
Door Lock	12 Brn.		16 Pnk/Yel	16 Pk/Lg	18 Blk/Red	12 Brn	16 Gray	16 White
#2	4	#	29	#	29	16 Wht	O8	16 White
Aux. Start	12 Brn.		14 Yel/Blk	#	6 Yel/Blk	16 Wht	16 Gray	16 White
#3	01	#	03	02	06	16 Wht	O8	16 White
Generator	18 Blk		18 Yellow	18 Brn	18 Red	16 Wht	16 Gray	16 White
#4	13	77S	78S	#	#	#	O8	16 White
Rear Heat	12 Blue	12 Rd/W	12 R/Wht	#	#	#	16 Gray	16 White
#5	4	#	21	#	#	#	O8	16 White
Aisle Lts.	12 Brn.		12 Grn/Whit	#	#	#	16 Gray	16 White
#6	19	#	20	#	#	#	O8	16 White
Drive Lts.	14 Brn.		14 Blue/Whit	#	#	#	16 Gray	16 White
#7	23	#	28	#	28	16 Wht	O8	16 White
Dock Lts.	10 Pink		10 Pur/Yel	#	16 Pur/Yel	16 Wht	16 Gray	16 White
#8	4		4A				O8	16 White
GALLEY Lts.	12 Brn.		2 Grn/Blk				16 Gray	16 White

HARNNESS, DASH LIGHTS

WIRE CHART

Circ.	Ga.	Color	Function
156	16	Green	Dash Lts, Ground
240	16	Orange	Dash Lts, +12
08	16	Gray	Instrument Lts. +12

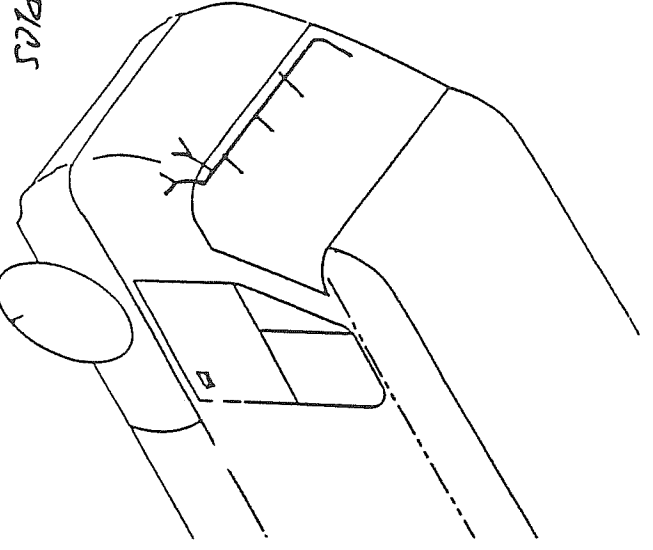
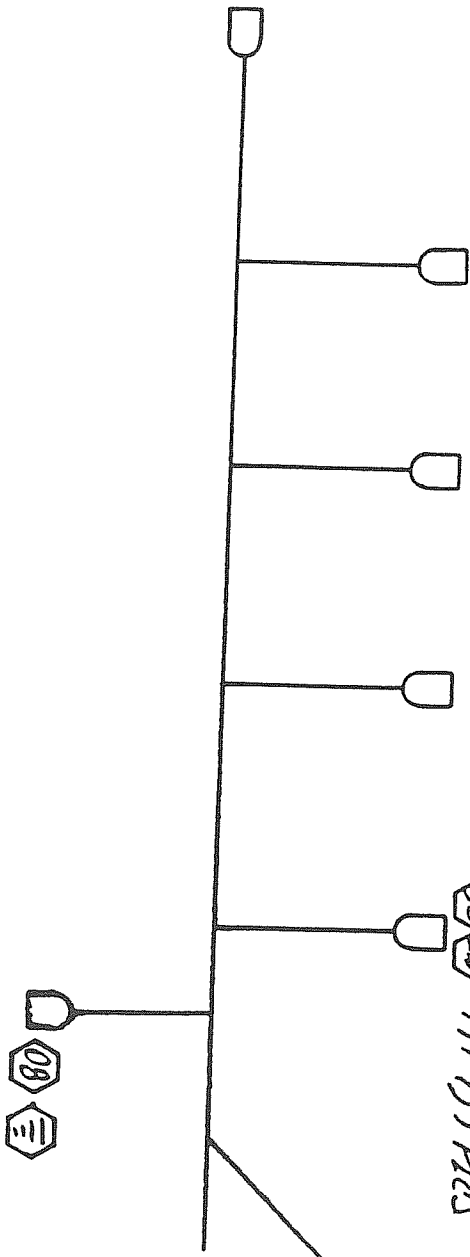

DASH LTS

08 240 TYP (5) PLCS

TO FIREWALL
REMOVE TERMINALS

TO FIREWALL
MAKE TERMINALS

HARNES, HEAD LIGHTS

WIRE CHART

Circ.	Ga.	Color	Function
28	14	Purple	Dock Ls.
36	14	Red	Driving Ls.

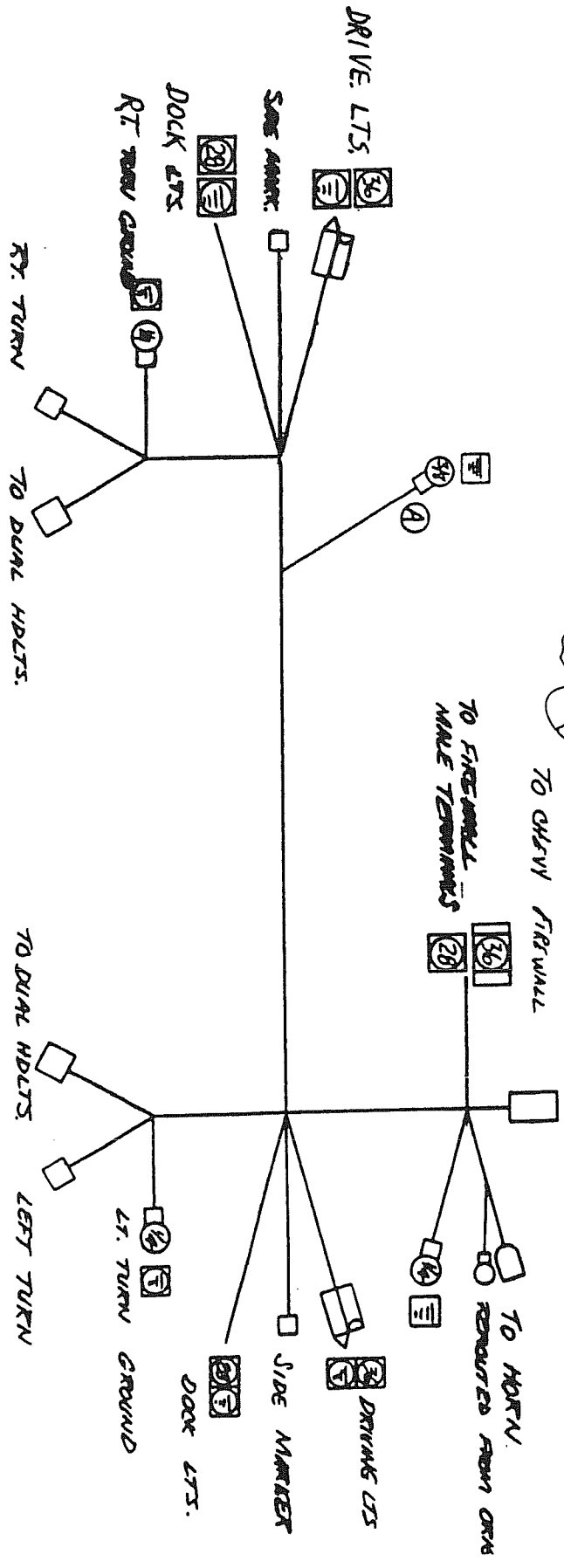
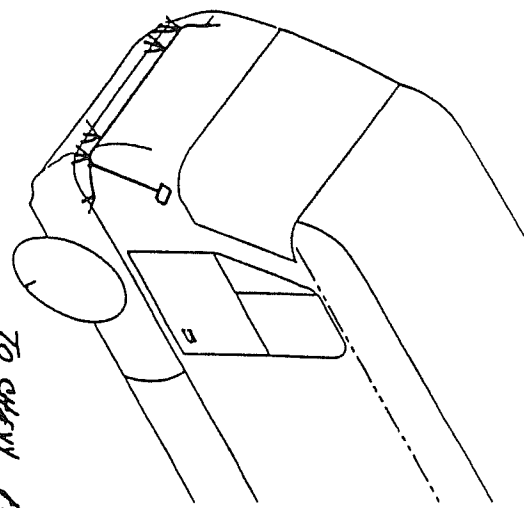

HARNES, TAIL LIGHTS

WIRE CHART

Circ.	Ga.	Color	Function
19	16	Brown	Tail lights
24	16	Yellow	Left Turn
25	16	Dk. Green	Right Turn
27	16	Lt. Green	Back-up

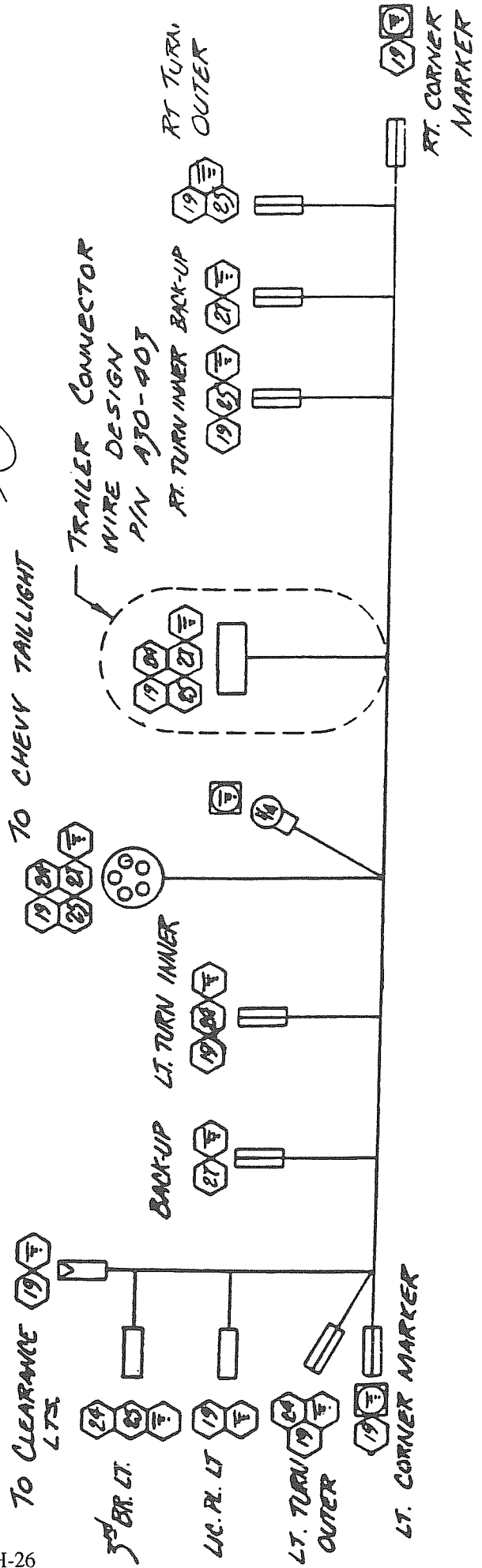
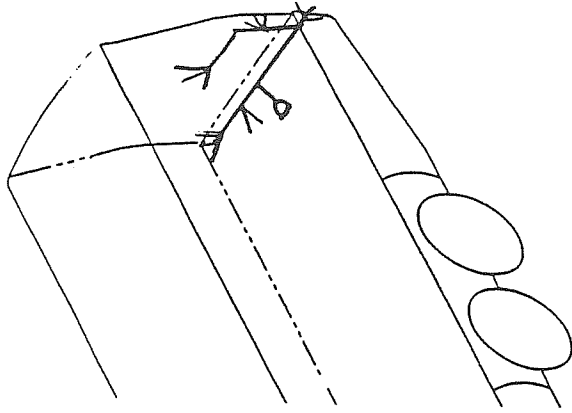

HARNES, DRIVERS DOOR

WIRE CHART

Circ.	Ga.	Color	Function
3	12	Orange	Cig. Lighter
15	12	Red	Pwr. Window
156	16	Green	Dash Lts, Ground
240	16	Orange	Dash Lts, 42

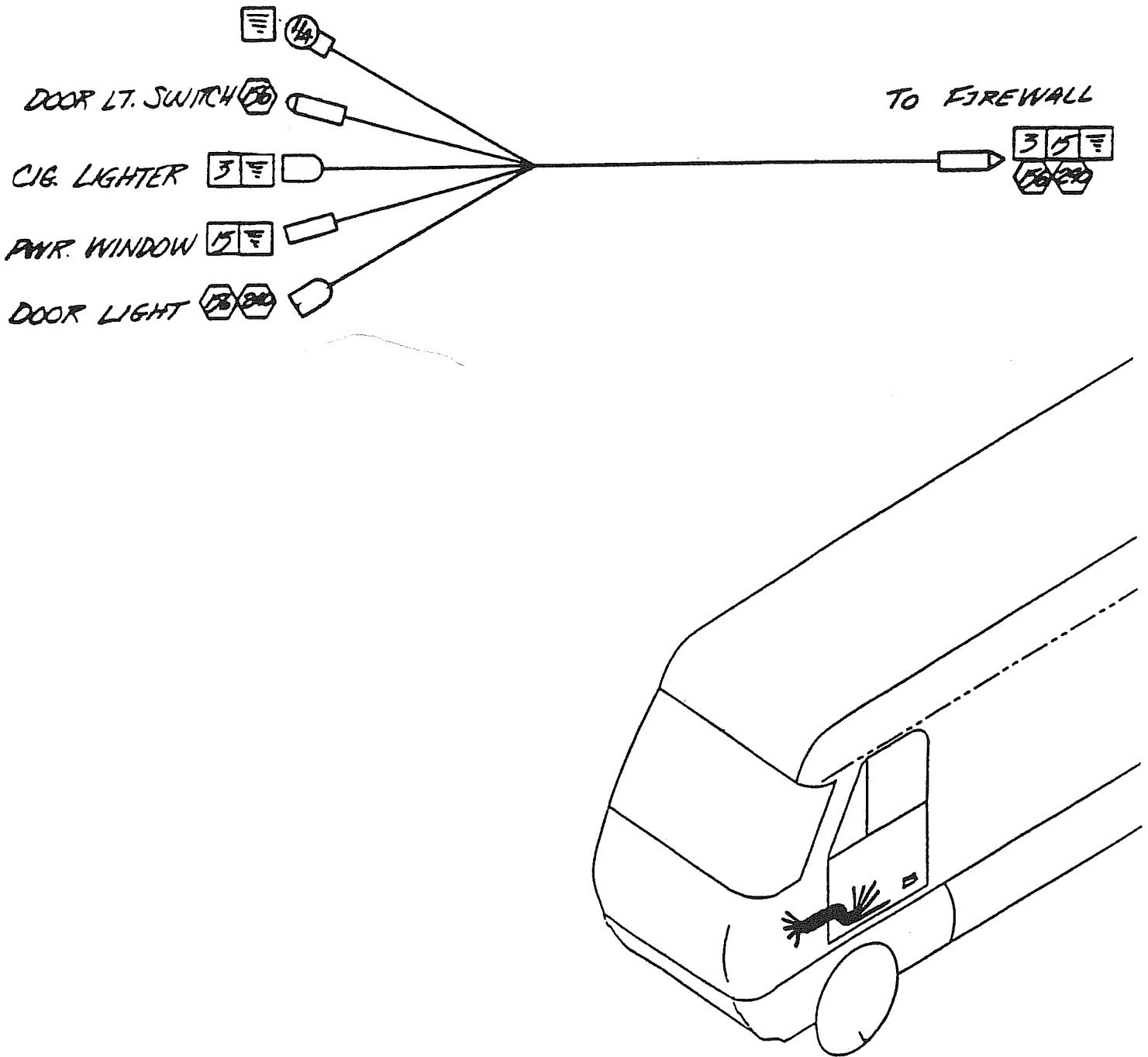

952518

LET DATE	EC.N.	REVISION RECORD	BY
10/94	4467D	PRODUCTION RELEASE	RA
A	9/95	4544B ADDED DSS RECEIVER WIRING	RA

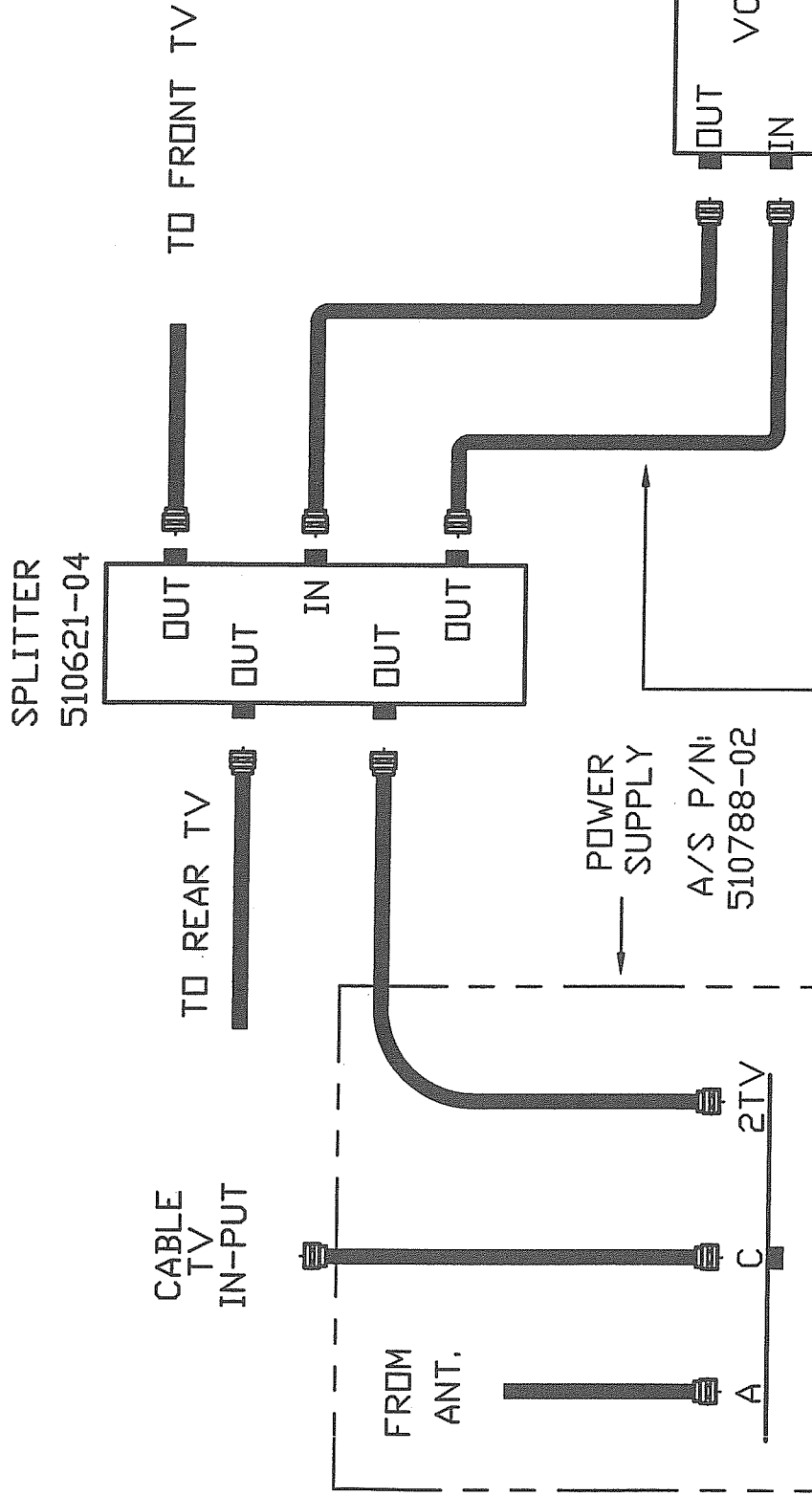

THIS CABLE NOT REQUIRED FOR VCP INSTALLATION

ITEM	PART NUMBER	DESCRIPTION	QTY	UM
TOLERANCES				
±				
NEXT ASSY				
DRAWN BY		R.L.A.		
APPROVED BY				
TITLE				
PRODUCT LINE		Motorhome		
Coax Cable Connections				
SCALE	DATE	DRAWING NUMBER	REV.	
None	10/17/94	952518	A	A

MONITOR PANEL

Ventline
P.O. Box 629
Bristol, Indiana 46507
Phone: 219-848-4491

Operation

To check tank capacities or battery condition, depress the switch marked "test." In order to obtain a true reading on the batteries, you must be unplugged from city power and disconnected from your tow vehicle.

The range exhaust fan has an exterior door that must be unlatched to be effective. You'll see the two small twist latches if you look at the fan from outside the motorhome. In most circumstances you can leave the door unlatched. During storage or adverse weather conditions, latching the door is recommended.

Trouble Shooting Guide

Be sure the wiring to the panel is correct and that the house battery is well charged. All electrical connections must be correct.

NOTE: RV's are subjected to a lot of vibration from traveling on the highways, so always look for broken wires and loose or broken connections.

NOTE: If a RV has exposed holding tanks under the vehicle and the vehicle is operated in the rain, sleet or snow, the panel may show incorrect tank levels due to electrical conductivity on the outside of the tanks. Washing the tanks and sealing the connections on the outside of the well nuts with silicon sealer should correct this condition.

PROBLEM: Fan does not operate.

CAUSE: A. No voltage to switch.
B. Defective switch, defective motor.

REMEDY: 1. Check for voltage, test switch, test motor.

PROBLEM: Fan operates on high speed but not on low speed.

CAUSES: A. Defective circuit board.

REMEDY: 1. Replace circuit board.

PROBLEM: Hood light does not operate.

CAUSES: A. Burned out bulbs.
B. No voltage to switch.
C. Defective switch.

REMEDY: 1. Test for voltage.
2. Test switch.
3. Test bulbs.

PROBLEM: Water pump does not operate.

CAUSES: A. No voltage to pump.
B. Defective switch or pump.
C. Pump not grounded.

REMEDY: 1. Test for voltage at switch.
2. Check ground.

PROBLEM: Water pump operates but red indicator light does not come on.

CAUSES: A. Faulty LED.
B. Faulty circuit board.

REMEDY: 1. Replace circuit board.

PROBLEM: "E" LED shows but indicator lights for amount of liquid in tank don't show.

CAUSES: A. Faulty connection in lead to tank.
B. Faulty circuit board.

REMEDY: 1. Check leads and connections at tank.
2. Replace circuit board.

PROBLEM: Condition of battery is not indicated when switch is pushed.

CAUSES: A. Faulty switch.
B. Faulty circuit board.
C. Circuit board not grounded.
D. Dead battery.

REMEDY: 1. Test Test switch, check ground.
2. Change circuit board.
3. Charge battery.

PROBLEM: No "E" light on water tanks when switch is pushed.

CAUSES: A. No power to panel.
B. Defective circuit board.

REMEDY: 1. Check fuses and power leads.
2. Repair or replace panel.

PROBLEM: Improper level indication on one or two tanks.

CAUSES: A. Faulty wiring from panel to sensors.
B. Faulty circuit board.
C. Dirty sensors and/or tank.

REMEDY: 1. Check wiring to sensors.
2. Clean sensors and tank.
3. Replace tank sensor harness.
4. Replace or repair circuit board.

PROBLEM: Improper level indication on all water tanks.

CAUSES: A. Faulty circuit board.

REMEDY: 1. Replace or repair circuit board.

PROBLEM: Panel shows LPG tank to be full all of the time.

CAUSES: A. Connection between tank and panel faulty.
B. Poor or no ground between tank and vehicle.
C. Faulty tank sending unit or faulty circuit board.

REMEDY: 1. Check and repair wiring from tank to panel and tank to ground.
2. Repair or replace tank sending unit.
3. Repair or replace circuit board.

PROBLEM: Panel shows LPG tank to be empty all of the time.

CAUSES: A. Short to ground in wire between panel and tank sending unit.
B. Faulty tank sending unit.
C. Faulty circuit board.

REMEDY: 1. Repair shorted wire.
2. Repair or replace sending unit.
3. Repair or replace circuit board.

NOTE: If the wire from the panel is removed from the tank, the panel indicator should show the tank full. If the panel wire to the tank is grounded, the panel should show the tank empty.

ADJUSTMENT INSTRUCTIONS FOR VENTLINE ADJUSTABLEBOARDS™

Ventline's latest printed circuit boards (PCB's) are equipped with potentiometers (pots) that allow the holding tank sensitivity to be adjusted. This adjustment is sometimes necessary to compensate for the difference in conductivity between liquids in the holding tanks. The intent of this feature is to compensate for minor fluctuations in the mineral content of the water, not to be used in place of regular maintenance of the holding tanks. The pots should not be adjusted to compensate for dirty holding tanks. A buildup of grease, soap by-products, etc. will cause a path of least resistance in the holding tank and cause the system to be oversensitive. The holding tanks should be cleaned regularly as recommended by the tank manufacturer. See section G of this manual.

The PCB's have one pot installed for each holding tank, they are located towards the top of the PCB. Each pot is identified on the back of the PCB with P1, P2, or P3 (ie, P1 = corresponds to the pot for holding tank 1). The monitor panel pots are initially set with the wiper blade fully clockwise. If a holding tank reading is oversensitive (the LED's are reading higher than the actual tank water level), the pot should be adjusted counterclockwise until the LED's read the correct level. Care should be taken not to force the pot past it's wiper blade limits. It is not necessary to remove the PCB from the monitor panel chassis to make these adjustments.

If you have any further questions regarding this subject, please contact VEntline Engineering at (219) 848-4491.

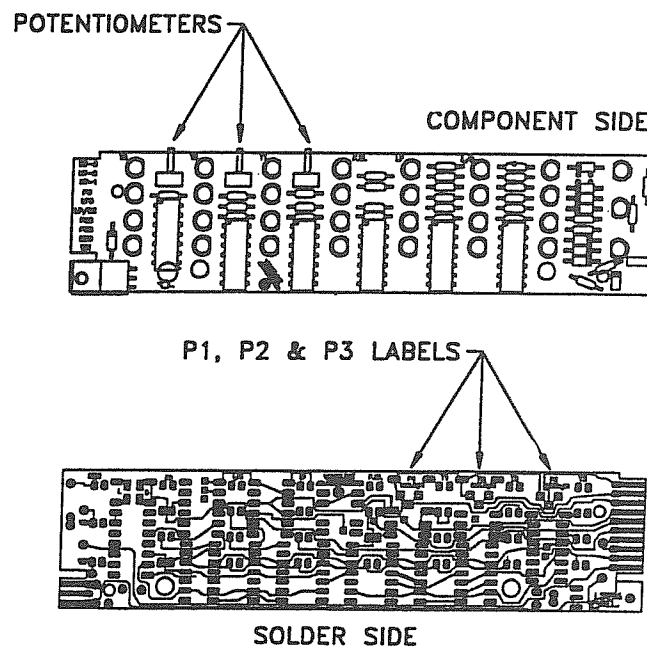

99

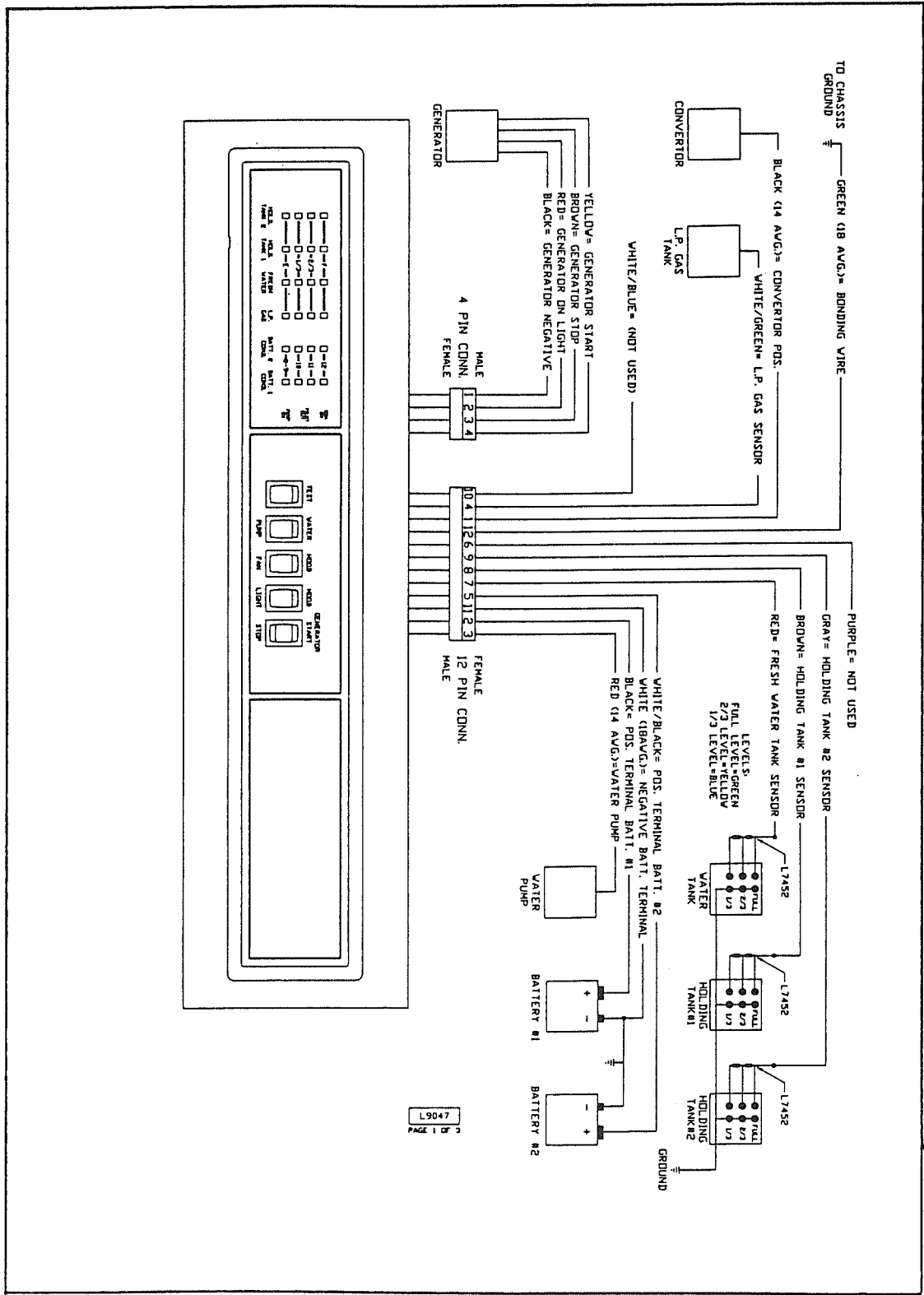

TV ANTENNA

Manufacturer: Winegard Company
3000 Kirkwood Street
Burlington, Iowa 52601
Phone: 800-843-4741

Raising Antenna to Operating Position

Turn elevating crank in "UP" direction until some resistance to turning is noted. Antenna is now in operating position. Check to make sure switch on front TV jack is on.

Rotating Antenna

Make sure antenna is in "UP" position. Pull down on directional handle with both hands until it disengages ceiling plate and rotate for best picture and sound on television set.

Lowering Antenna to Travel Position

Rotate antenna until pointer on directional handle aligns with pointer on ceiling plate.

WARNING: Antenna must be in "down" position while traveling to prevent damage.

Turn elevating crank in the "Down" direction until resistance is noted. Antenna is now locked in travel position.

Checking Operation

1. Tune TV receiver to nearest station and rotate antenna for lowering Antenna best picture and sound.
2. Turn off switch on power supply. Picture on TV receiver should be considerably degraded with power off.

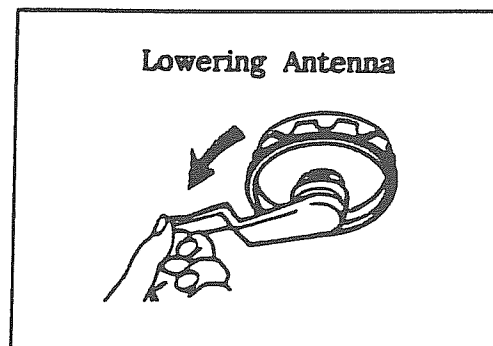
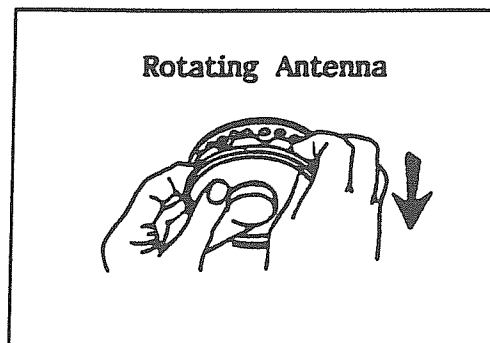
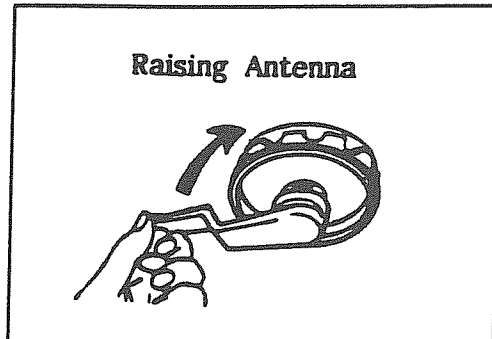

DO'S

1. Do check parking location for obstructions before raising antenna.
2. Do carefully raise, lower and rotate - if difficult, check for cause.
3. Do rotate slowly when selecting station and check fine tuning on TV set to make sure it is properly adjusted.
4. Do lower antenna before moving vehicle.

DONT'S

1. Don't force elevating crank up or down. Check for cause of trouble.
2. Don't rotate directional handle hard against stops.
3. Don't travel with lift in up position.
4. Don't leave lift part way up or down.
5. Don't apply sealing compound or paint over top of base plate or anywhere on lift.

Maintenance

Lubrication

To lubricate the elevating gear apply a liberal amount of silicone spray lubricant to the elevating gear with the lift in the down position, then run the lift up and down a few times to distribute lubricant over gears.

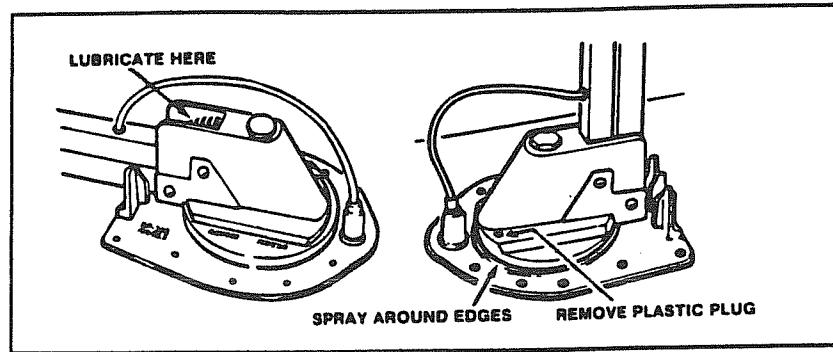

Lubricating Rotating Gear Housing

In the event that rotating the antenna becomes difficult, normal operation can be restored by lubricating the bearing surface between the rotating gear housing and the base plate. Any spray type silicone lubricant may be used.

Elevate antenna and remove set screw from rotating gear housing as shown. Spray lubricant into hole and around edges of gear housing. Rotate gear housing until lubricant coats bearing surfaces and antenna rotates freely.

Elevating Shaft Worm Gear Assembly Replacement Procedure

STEP 1: Lower antenna to travel position and refer to drawing to identify parts indicated in steps below.

STEP 2: Loosen set screw on elevating crank (#1) and remove crank (#1), spring (#2), directional handle (#3).

STEP 3: Go to roof of vehicle and remove retaining ring from pin (#5) holding top elevator tube in rotating gear housing and remove pin.

STEP 4: Remove bearing plug (#4) from top of rotating gear housing. Disengage elevating gear (#6) and remove elevating shaft assembly (#7).

Note: Make sure all parts below worm gear are removed from rotating gear housing. These include bearing, quad ring and one or two washers.

STEP 5: Cut new shaft 1/4" longer than old shaft. See Illus: Discard old bearing plug item (#4).

STEP 6: Lubricate worm gear on new elevating shaft assembly with spray silicone lubricant, make sure quad ring, washer and wave washer are on lower bearing and insert assembly in housing.

STEP 7: Install new plastic bearing plug in top of housing. Re-engage elevating gear in worm gear. Replace pin and retaining ring.

STEP 8: Replace directional handle, spring and elevating crank. Make sure set screw contacts flat on shaft before tightening.

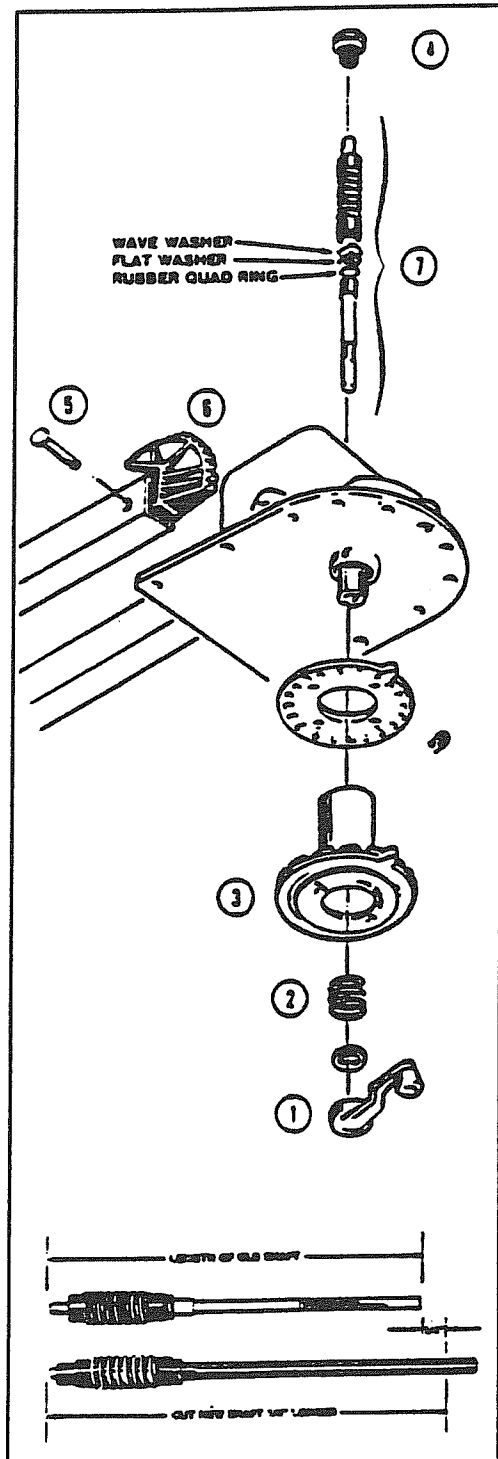

ANTENNA, RADIO, CB, CELLULAR TELEPHONE

Not including the TV antenna, your motorhome may have as many as three other antenna.

The AM/FM **radio antenna** is a solid whip type with a flexible coil base. The coil base certainly helps extend the life of the antenna but hitting low branches and other objects at high speed can lead to severe damage.

The optional **C.B. antenna**, if factory installed will have been adjusted to obtain maximum performance and no further adjustment should be required.

The lead-in wire from the **cellular phone** antenna is coiled under the dash behind the kick panel in front of the passenger cab seat. The panel is removed by taking out the screws you can see through the vent grill and there are a couple of screws along the vertical right side of the panel.

SOLAR POWER

The 5 watt system installed in your motorhome primarily functions as a battery maintainer. Memory functions in radios, locks and the circuit boards in some safety devices each draw power in the milliamp range. If a charge source is not available, even these miniscule power drains will run your chassis batteries down in a few days. Barring an unusual number of cloudy days the solar system will keep your chassis batteries in pretty good condition.

Turning your auxiliary battery switch off at the dash will help maintain the charge in both the chassis and coach batteries.

110 VOLT POWER

The 110-volt system works very much like your home. When you're plugged into city power or start your generator, power is supplied to the 110-volt circuit breakers. The circuit breakers are located under the front of the rear bed.

If a circuit is over loaded or a short circuit occurs, the breakers will "kick" out. To reactivate the circuits, turn the breaker to off, reduce the load or correct the short, and turn the breaker back to on.

One of the easiest and least disturbing way to reduce the 110 volt load is to turn off the water heater switch in the bathroom. The water heater element draws about 12 amps.

One of the breakers is a GFI (Ground Fault Interrupter) breaker. The intent of this breaker is to sense any loss of ground before a harmful shock could occur, and kick the breaker out. These sensitive breakers are installed in the circuit feeding the bathroom, outside receptacle, and galley area. These are the areas where the use of water or the wet ground could put a person in danger of shock. Since the GFI breaker is so sensitive, it is not unusual to have it kick out for no apparent reason.

To protect linemen from an unexpected shock the generator must be wired through a switch over box.

Generator/City Power

- A. to 110 volt circuit breakers
- B. to generator 30 amp circuit
- C. to city power

When plugged into city power, the current path is from C to A. When you start your generator and unplug from city power, the points switch and the power flow is from B to A. If you're plugged into city and you start the generator, city power has the priority, so the current flow is C to A.

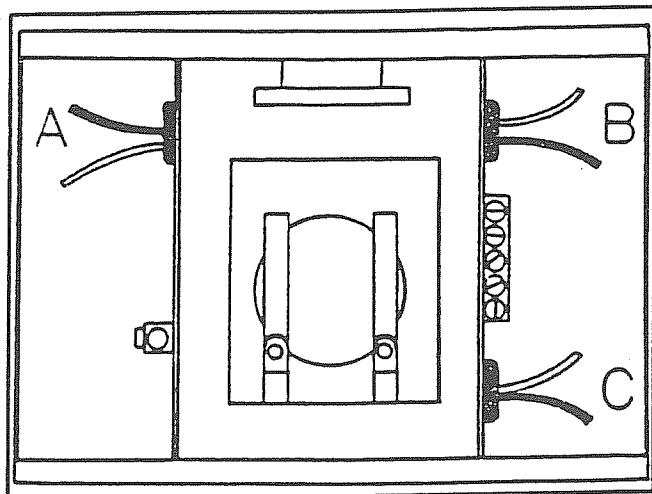

Rear Air Conditioner

- A. to rear air conditioner
- B. generator 20 amp circuit
- C. to front/rear air conditioner priority switch

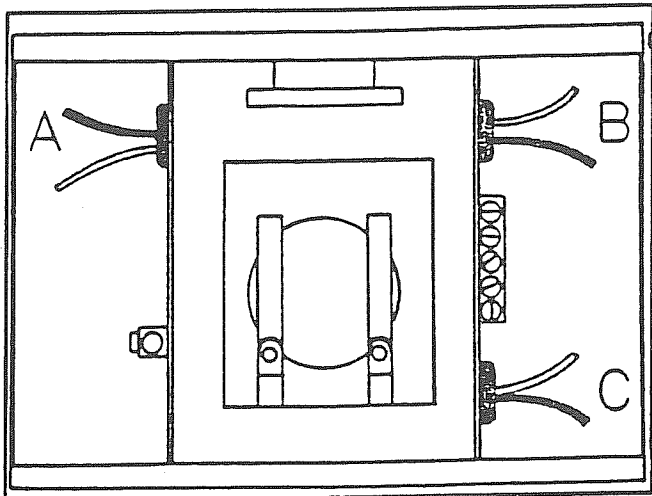

When you have the optional 50 amp service, the red wire shown on the following diagram will be providing power to the rear air conditioner whether you are plugged into city power or operating the generator.

SWITCH OVER BOX - 50 AMP

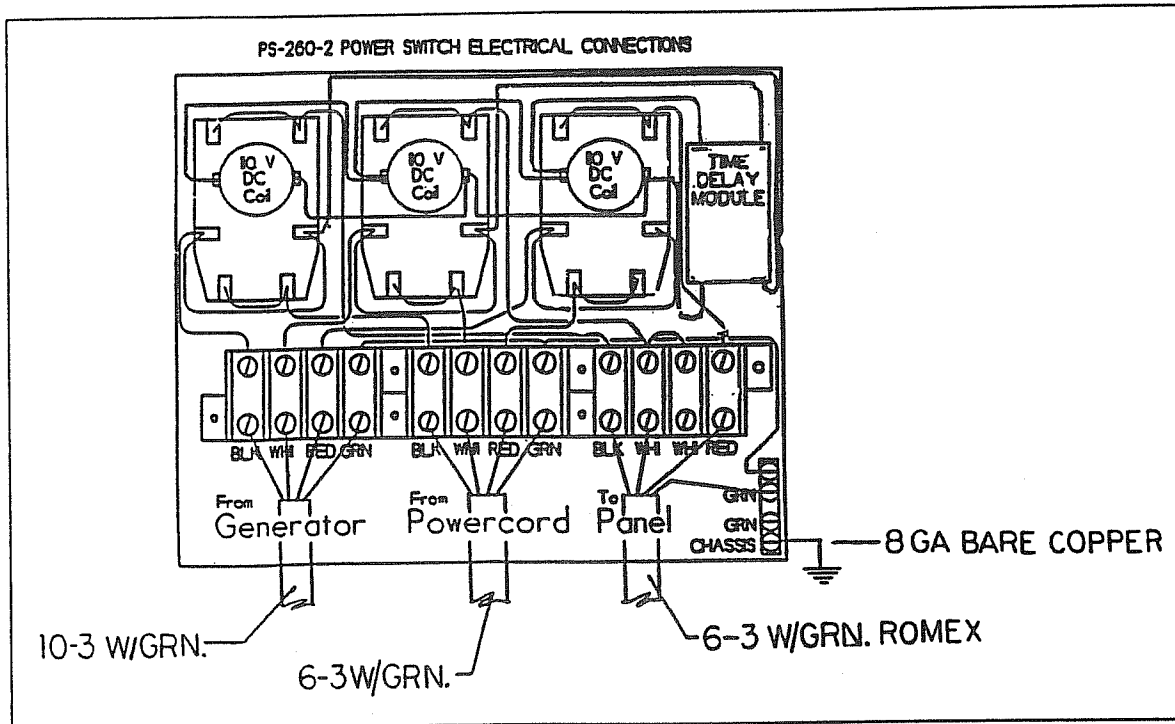

Locating Shorts and Opens

The key in locating shorts and opens is isolation. The first step is to isolate the circuit with the short or open. The second step is to then isolate the section of the circuit with the fault. Once the section is identified, the specific problem can be located. The cause may be a loose or corroded connection, cut wire, worn insulation, defective component, etc. The following procedure is one method for isolating shorts and opens.

SHORTS

1. Isolate the circuit which has the short by noting which circuit breaker has tripped.
2. Disconnect the power inlet cord from the power source.
3. Using the 120V schematic as a reference, disconnect outlet boxes one at a time starting at the box furthest from the distribution panel. After disconnecting each box, check for continuity between the black wire and ground or common (white) wire on the distribution panel side of the circuit. When a continuity light or ohmmeter indicates no continuity, the short is either in the receptacle just removed or the section of Romex wire between this receptacle and the previous receptacle removed.
4. Examples of a short are: A) The black wire of the 120V system contacting the white wire, bare wire or grounded surface. B) An internal short in a 120V appliance.

Any damaged wire must be replaced. The National Electrical Code does not permit splicing 120V wiring outside an outlet box or junction box. Also, the wire must not be exposed to an area such as a sharp metal edge which may damage the wire.

OPENS

1. Check all receptacles and components for voltage on the circuit which has the open.
2. If all receptacles and components of the circuit are without power, begin to look for open in the distribution panel.
3. Inspect for loose or corroded connections and a faulty circuit breaker.
4. Check for power on both ends of circuit breaker. If there is no power on the inlet side of the circuit breaker, the open is between the power cord's male connector and the distribution panel.
5. The open can be isolated by noting the outlets which do not have power. Example: If the bath outlet in the rear bath model has power and the converter has no power, the open is between the bath outlet and converter outlet.
6. Examples of an open are: A) Loose or corroded connections. B) A wire disconnected from a terminal. C) Contacts in the circuit breaker which do not make contact. D) A broken wire.

120V WIRING DIAGRAMS

- 120 volt distribution - 30 amp
- 120 volt distribution - 30 amp
- 120 volt wiring - 30 foot, 30 amp
- 120 volt wiring - 30 foot, 50 amp
- 120 volt wiring - 33 foot, 30 amp
- 120 volt wiring - 33 foot, 50 amp

952489

WESTINGHOUSE TT 120 ELGNM 120 VAC
CLASS CTL ENCLOSED PANELBOARD

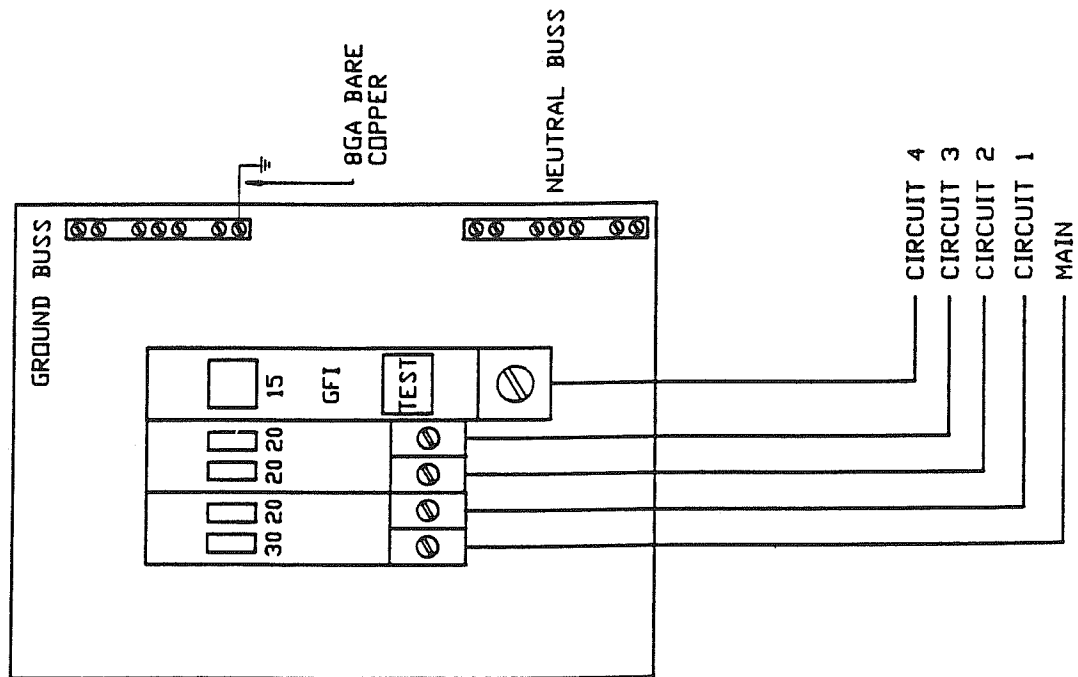

MAIN

- CIRCUIT 1, 20 AMP HACR BREAKER, 12-2 ROMEX W/GROUND, FRONT/REAR A/C'S.
- CIRCUIT 2, 20 AMP HACR BREAKER, 12-2 ROMEX W/GROUND, BEDROOM, CONVERTER, LIVING AREA.
- CIRCUIT 3, 20 AMP HACR BREAKER, 12-2 ROMEX W/GROUND, MICROWAVE
- CIRCUIT 4, 15 AMP GFI BREAKER, 12-2 ROMEX W/GROUND, LEG 1, BATH, OUTSIDE, REFER, GALLEY AREA, DINETTE.

USAGE:

- A/S TRAILERS-25'SB, 28'SB
- 30'FK, 30'SB, 34'SB
- A/S MOTORHOMES-360, 360 PUSHER
- LAND YACHT MOTORHOMES-30'SB, 33'SB,
- 34'SB PUSHER, 36'SB
- LAND YACHT LE-30'SB, 34'SB,
- 34'SB PUSHER

LET	DATE	E.C.N.	REVISION RECORD	BY
	3/94	4458	PRODUCTION RELEASE	R.A.

ITEM	PART NUMBER	DESCRIPTION	QTY	UOM
TOLERANCES		<i>Airstream</i>		DRAWN BY <i>Ambrosio</i>
±				APPROVED BY
NEXT ASS'Y		PRODUCT LINE	SEE NOTE	
TITLE 30 AMP. BREAKER PANEL				
SCALE	DATE	DRAWING NUMBER	REV.	
NONE	03/03/94	952489		B

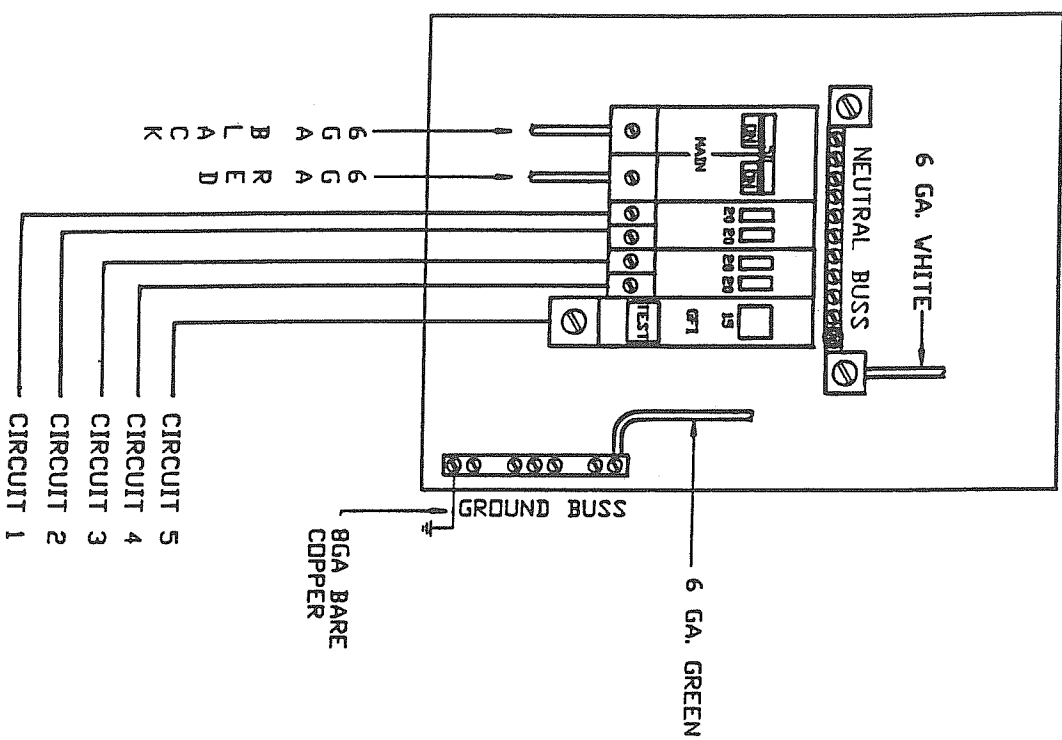

- CIRCUIT 1, 20 AMP HACR BREAKER, 12-2 ROMEX W/GROUND, LEG 1, FRONT A/C.
- CIRCUIT 2, 20 AMP HACR BREAKER, 12-2 ROMEX W/GROUND, LEG 1, BEDROOM, CONVERTER, LIVING AREA.
- CIRCUIT 3, 20 AMP HACR BREAKER, 12-2 ROMEX W/GROUND, LEG 2, REAR A/C.
- CIRCUIT 4, 20 AMP HACR BREAKER, 12-2 ROMEX W/GROUND, LEG 2, MICROWAVE.
- CIRCUIT 5, 15 AMP GFI BREAKER, 12-2 ROMEX W/GROUND, LEG 1, BATH, OUTSIDE, REFER, GALLEY AREA.

Note:
 Usage: 360 A/S Classic Mh., 30 L/Y Mh.

SQUARE 'D' LOAD CENTER
 CATALOG NO. Q06-12L100T
 SERIES G1
 TYPE 1 ENCLOSURE
 120/240V. A.C. 1 PH. 3W.
 MAINS 100 MAX.
 UL/CSA CERTIFIED

LET	DATE	E.C.N.	REVISION RECORD	BY
	2/94		PRODUCTION RELEASE	R.A.

ITEM	PART NUMBER	DESCRIPTION	QTY	U/M
TOLERANCES				
±				
NEXT ASS'Y				
DRAWN BY		<i>Amal Singh</i>		
APPROVED BY				
PRODUCT LINE		See note		
TITLE				
110V. BRKR. PANEL-50 AMP				
SCALE	DATE	DRAWING NUMBER	REV.	
NONE	02/08/94	952460	B	

952487

LET DATE		E.C.N.		REVISION RECORD		BY	
A	5/94	4465	4458	3/94	4458	Production Release	RA
						Revise VCP Wiring	TC

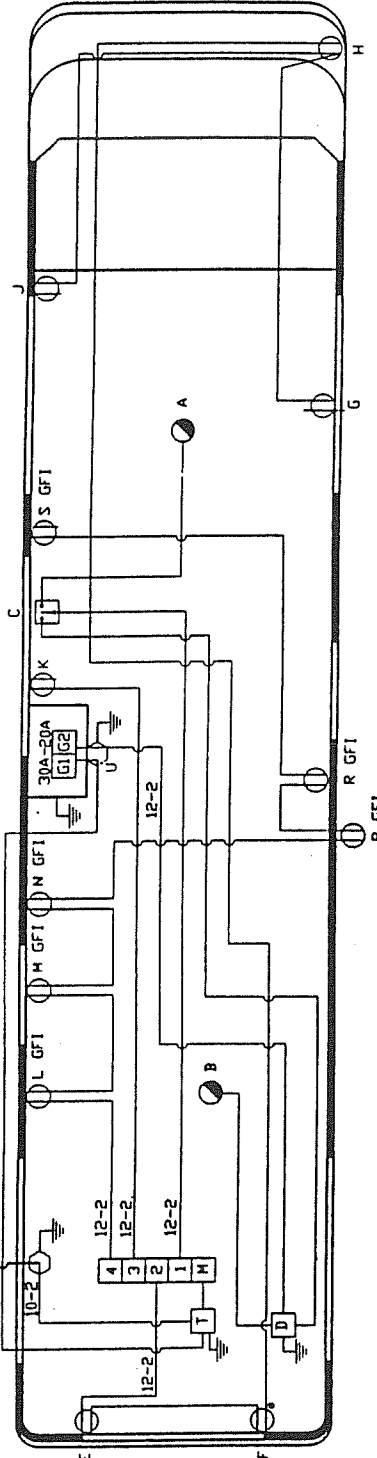

CIRCUIT 1. 20 AMP. HACR BREAKER, 12-2 ROMEX V/GRD. THIS CIRCUIT, WHEN OPERATING FROM SHORELINE SUPPLIES POWER TO SINGLE POLE, DOUBLE THROW SWITCH 'C' WHICH WILL OPERATE EITHER FRONT A/C 'A' OR REAR A/C 'B' (16 AMP MAX) DEPENDING ON THE SWITCH POSITION. WHEN THE GENERATOR IS OPERATING, AUTOMATIC SWITCHOVER RELAY 'D' WILL OVERRIDE SHORELINE AND OPERATE REAR A/C 'B' WITH POWER SUPPLIED THROUGH GENERATOR CIRCUIT G-2. IF THE PRIORITY SWITCH IS IN THE FRONT A/C POSITION, IT WILL OPERATE FRONT A/C 'A' WITH POWER SUPPLIED FROM GENERATOR CIRCUIT G-1.

CIRCUIT 2. 20 AMP. HACR BREAKER, 12-2 ROMEX V/GRD.
 E. RUABSIDE BEDROOM RECEIPT 1.0 AMPS.
 F. CURBSIDE BEDROOM RECEIPT 1.0 AMPS.
 G. CRENZENZA RECEIPT 1.0 AMPS.
 H. CONVERTER RECEIPT 60 AMPS.
 J. VCP RECEIPT 0.23AMPS.
TOTAL 11.23 AMPS.

CIRCUIT 3. 20 AMP. HACR BREAKER, 12-2 ROMEX V/GRD.
 K. MICROWAVE OVEN RECEIPT 12.0 AMPS.

CIRCUIT 4. 15 AMP. GFI BREAKER, 12-2 ROMEX V/GRD.
 L. MAKE-UP TABLE 1.0 AMPS.
 M. BATH RECEIPT 1.0 AMPS.
 N. REFER RECEIPT 2.7 AMPS.
 P. OUTSIDE RECEIPT 1.0 AMPS.
 R. DINETTE RECEIPT 1.0 AMPS.
 S. GALLEY RECEIPT 1.0 AMPS.
TOTAL 7.7 AMPS.

GEN. CIRCUIT G-1 FROM THE GENERATOR 30A BREAKER, 10 GA. STRANDED WIRE IS RUN IN FLEXIBLE METAL CONDUIT TO J-BOX 'U'. FROM THERE, 10-2 ROMEX V/GRD. IS RUN TO THE BREAKER BOX THROUGH AUTOMATIC SWITCH-OVER RELAY 'I'.

GEN. CIRCUIT G-2, FROM THE GENERATOR 20 AMP. BREAKER, 12 GA. STRANDED WIRE IS RUN IN FLEXIBLE METAL CONDUIT TO J-BOX 'U'. FROM THERE, 12-2 ROMEX V/GRD. IS RUN TO AUTOMATIC SWITCHOVER RELAY 'D' WHICH WILL OVERRIDE SHORELINE AND OPERATE REAR A/C 'B'.

ITEM	PART NUMBER	DESCRIPTION	QTY	UM
TOLERANCES				
±				
NEXT ASSY				
		<i>Airstream</i>		DRAWN BY R.L.A.
		PRODUCT LINE	30' L/Y Mh.	APPROVED BY
TITLE 110V. Lay-out 30AMP				
SCALE	DATE	DRAWING NUMBER	REV.	
1=32	03/01/94	952487	B	A

952495

LET DATE		E.C.N.		REVISION RECORD		BY
	3/94	44584	Production Release			TC
A	5/94	4465	Revise VCP Wiring			TC

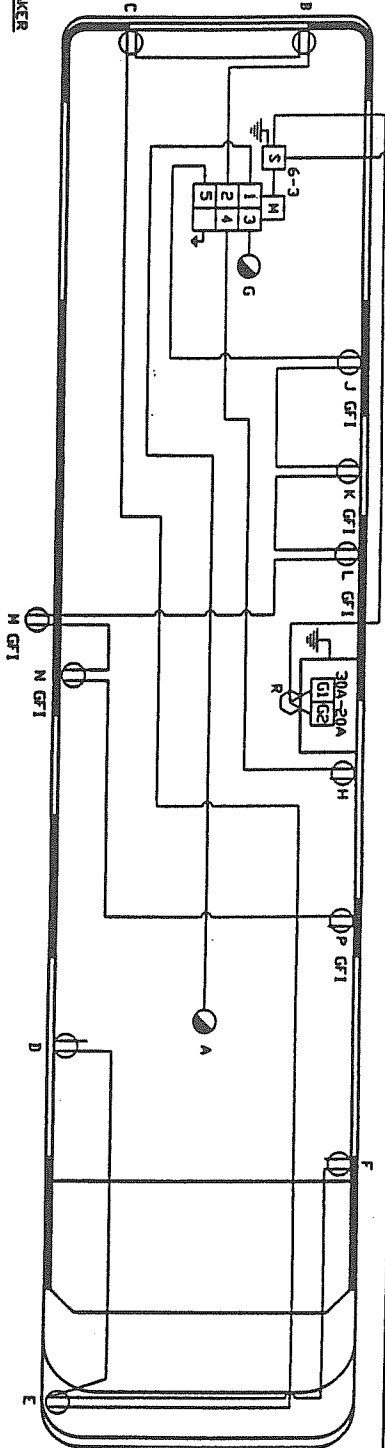

MAIN-50 AMP BREAKER

CIRCUIT 1 20 AMP HACR BREAKER, 12-2 ROMEX V/GRD, LEG-1
A. FRONT AIR CONDITIONER 16.0 AMPS.

CIRCUIT 2 20 AMP HACR BREAKER, 12-2 ROMEX V/GRD, LEG-1
B. ROADSIDE BEDROOM RECEPT 1.0 AMPS.
C. CURBSIDE BEDROOM RECEPT 1.0 AMPS.
D. CRENZEA RECEPT 8.0 AMPS.
E. CONVERTER RECEPT 0.23AMPS.
F. VCP RECEPT 11.23 AMPS.

CIRCUIT 3 20 AMP HACR BREAKER, 12-2 ROMEX V/GRD, LEG-2
G. REAR AIR CONDITIONER 16.0 AMPS.

CIRCUIT 4 20 AMP HACR BREAKER, 12-2 ROMEX V/GRD, LEG-2
H. MICROVAVE OVEN RECEPT 12.0 AMPS.

CIRCUIT 5 15 AMP GFI BREAKER, 12-2 ROMEX V/GRD, LEG-1
J. MAKE-UP TABLE RECEPT 1.0 AMPS.
K. BATH RECEPT 1.0 AMPS.
L. REFER RECEPT 2.7 AMPS.
M. OUTSIDE RECEPT 1.0 AMPS.
N. DINETTE RECEPT 1.0 AMPS.
P. GALLEY RECEPT 1.0 AMPS.

TOTAL 7.7 AMPS

GENERATOR CIRCUITS. THE GEN SET COMES EQUIPPED WITH A 30 AMP AND 20 AMP BREAKER. WIRES COMING FROM THESE BREAKERS ARE STRANDED COPPER AND ARE RUN IN FLEXIBLE METAL CONDUIT TO J-BOX 'R'. THE GENERATOR WIRES ARE JOINED TO A 10-3 ROMEX V/GROUND WIRE IN THE J-BOX AS FOLLOWS: THE 10 GA. STRANDED 'HOT' WIRE FROM THE 30 AMP BREAKER IS CONNECTED TO THE BLACK WIRE OF THE 10-3 ROMEX. THE STRANDED 12 GA. 'HOT' WIRE FROM THE 20 AMP BREAKER IS CONNECTED TO THE RED WIRE OF THE 10-3 ROMEX. THE STRANDED WHITE 'NEUTRAL' WIRES FROM THE GENERATOR BREAKERS CONNECT WITH THE WHITE WIRE OF THE 10-3 ROMEX. THE STRANDED GREEN 'GROUND' WIRE FROM THE GENERATOR BREAKERS CONNECT WITH THE COPPER GROUND WIRE OF THE 10-3 ROMEX. THE 10-3 ROMEX V/GROUND IS RUN TO AUTOMATIC SWITCHOVER RELAY 'S' WHICH WILL OVERRIDE SHORELINE WHEN THE GENERATOR IS OPERATING FOR DETAILS OF THE AUTOMATIC SWITCHOVER RELAY SEE DWG. 952459.

ITEM	PART NUMBER	DESCRIPTION	QTY	U/M
TOLERANCES				
±				
NEXT ASSY				
TITLE		DRAWN BY		
110V., 50 AMP. Layout		T.C.		
SCALE		APPROVED BY		
1=32		B		
DATE		REV.		
03/15/94		A		
DRAWING NUMBER				
952495				

952412

LET	DATE	E.C.N.	REVISION RECORD
	3/94	4458	Production Release
			RA

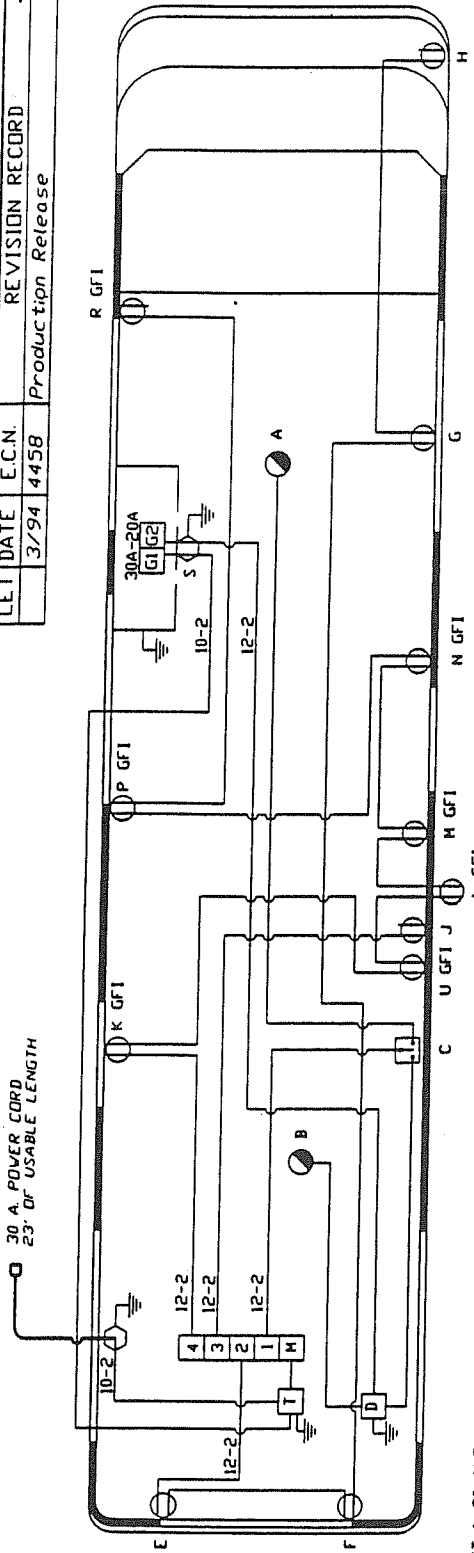

CIRCUIT 1. 20 AMP. HACR BREAKER, 12-2 ROMEX V/GRD. THIS CIRCUIT, WHEN OPERATING FROM SHORELINE, SUPPLIES POWER TO SINGLE POLE, DOUBLE THROW SWITCH 'C' WHICH WILL OPERATE EITHER FRONT A/C 'A' OR REAR A/C 'B' (16 AMP MAX.) DEPENDING ON THE SWITCH POSITION. WHEN THE GENERATOR IS OPERATING, AUTOMATIC SWITCHOVER RELAY 'D' WILL OVERRIDE SHORELINE AND OPERATE REAR A/C 'B' WITH POWER SUPPLIED THROUGH GENERATOR CIRCUIT G-2. IF THE PRIORITY SWITCH IS IN THE FRONT A/C POSITION, IT WILL OPERATE FRONT A/C 'A' WITH POWER SUPPLIED FROM GENERATOR CIRCUIT G-1.

CIRCUIT 2. 20 AMP. HACR BREAKER, 12-2 ROMEX V/GRD.
 E. ROADSIDE BEDROOM RECEPT 10 AMPS.
 F. CURBSIDE BEDROOM RECEPT 10 AMPS.
 G. CREDEENZA RECEPT 10 AMPS.
 H. CONVERTER RECEPT 8.0 AMPS.
 TOTAL 11.0 AMPS.

CIRCUIT 3. 20 AMP. HACR BREAKER, 12-2 ROMEX V/GRD.
 J. MICROWAVE OVEN RECEPT 12.0 AMPS.

CIRCUIT 4. 15 AMP. GFI BREAKER, 12-2 ROMEX V/GRD.
 K. BATH RECEPT 10 AMPS.
 L. OUTSIDE RECEPT 10 AMPS.
 M. GALLEY RECEPT 10 AMPS.
 N. DINETTE RECEPT 10 AMPS.
 P. VCP RECEPT 0.23 AMPS.
 U. REFER RECEPT 2.7 AMPS.
 TOTAL 79.93 AMPS.

GEN. CIRCUIT G-1. FROM THE GENERATOR 30A BREAKER, 10 GA. STRANDED WIRE IS RUN IN FLEXIBLE METAL CONDUIT TO J-BOX 'S'. FROM THERE, 10-2 ROMEX V/GRD. IS RUN TO THE BREAKER BOX THROUGH AUTOMATIC SWITCH-OVER RELAY 'T'.

GEN. CIRCUIT G-2. FROM THE GENERATOR 20 AMP. BREAKER, 12 GA. STRANDED WIRE IS RUN IN FLEXIBLE METAL CONDUIT TO J-BOX 'S'. FROM THERE, 12-2 ROMEX V/GRD. IS RUN TO AUTOMATIC SWITCHOVER RELAY 'D' WHICH WILL OVERRIDE SHORELINE AND OPERATE REAR A/C 'B'.

ITEM	PART NUMBER	DESCRIPTION	QTY	UN
TOLERANCES				
±				
NEXT ASSY				
		<i>Airstream</i>	DRAWN BY R.L.A.	
		PRODUCT LINE 33' L/Y Mfg.	APPROVED BY	
TITLE 110V. Lay-out 30AMP				
SCALE	DATE	DRAWING NUMBER	REV	
1=32	03/01/94	952412	B	

952493

50 A. POWER CORD
23' OF USABLE LENGTH

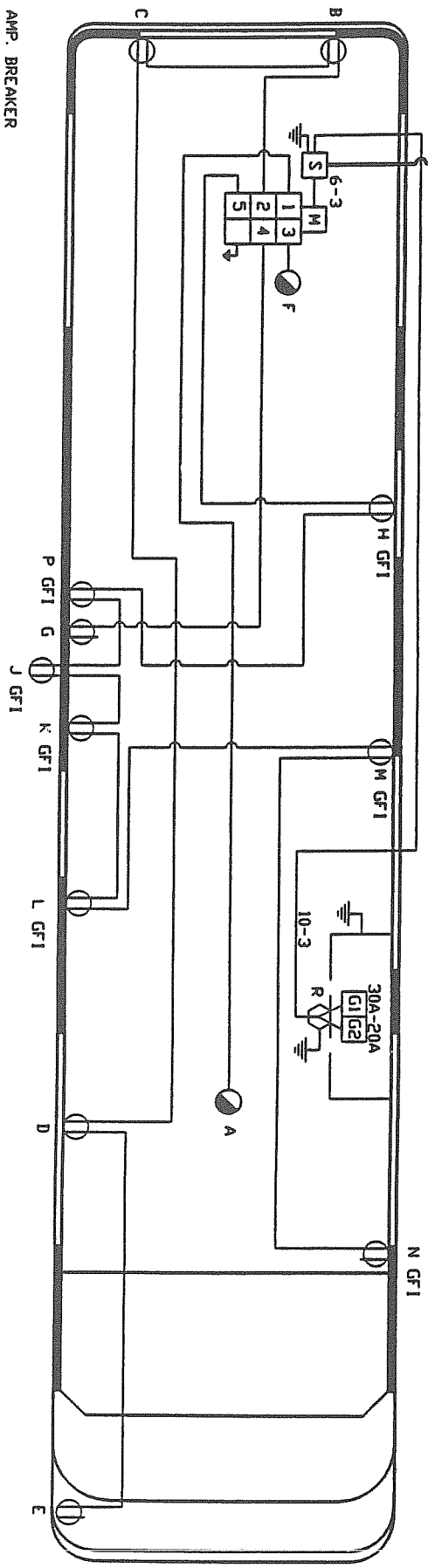

MAIN-50 AMP. BREAKER

CIRCUIT 1. 20 AMP. HACR BREAKER, 12-2 ROMEX V/GRD, LEG-1
A. FRONT AIR CONDITIONER 16.0 AMPS.

CIRCUIT 2. 20 AMP. HACR BREAKER, 12-2 ROMEX V/GRD, LEG-1
B. ROADSIDE BEDROOM RECEPT 1.0 AMPS.
C. CURBSIDE BEDROOM RECEPT 1.0 AMPS.
D. CRECENZA RECEPT 1.0 AMPS.
E. CONVERTER RECEPT 8.0 AMPS.
TOTAL 11.0 AMPS.

CIRCUIT 3. 20 AMP. HACR BREAKER, 12-2 ROMEX V/GRD, LEG-2
F. REAR AIR CONDITIONER 16.0 AMPS.

CIRCUIT 4. 20 AMP. HACR BREAKER, 12-2 ROMEX V/GRD, LEG-2
G. MICROWAVE OVEN RECEPT 12.0 AMPS.

CIRCUIT 5. 15 AMP. GFI BREAKER, 12-2 ROMEX V/GRD, LEG-1
H. BATH RECEPT 1.0 AMPS.
I. OUTSIDE RECEPT 1.0 AMPS.
K. GALLEY RECEPT 1.0 AMPS.
L. GALLEY RECEPT 1.0 AMPS.
M. DINETTE RECEPT 1.0 AMPS.
N. VCP RECEPT 0.23AMPS.
P. REFER RECEPT 2.7 AMPS.

TOTAL 79.3AMPS.

LET	DATE	E.C.N.	REVISION RECORD	BY
	3/94	4458A	Production Release	TC

GENERATOR CIRCUITS: THE GEN SET COMES EQUIPPED WITH A 30 AMP. BREAKER. WIRES COMING FROM THESE BREAKERS ARE STRANDED COPPER AND ARE RUN IN FLEXIBLE METAL CONDUIT TO J-BDX 'R'. THE GENERATOR WIRES ARE JOINED TO A 10-3 STRANDED, 'HOT' WIRE FROM THE 30 AMP. BREAKER IS CONNECTED TO THE BLACK WIRE OF THE 10-3 ROMEX. THE STRANDED, 'HOT' WIRE FROM THE 20 AMP. BREAKER IS CONNECTED TO THE RED WIRE OF THE 10-3 ROMEX. THE STRANDED, WHITE, 'NEUTRAL' WIRES FROM THE GENERATOR BREAKERS CONNECT WITH THE WHITE WIRE OF THE 10-3 ROMEX. THE STRANDED, GREEN 'GROUND' WIRE FROM THE GENERATOR BREAKERS CONNECT WITH THE COPPER GROUND WIRE OF THE 10-3 ROMEX. THE 10-3 ROMEX V/GROUND IS RUN TO AUTOMATIC SWITCHOVER RELAY 'S' WHICH WILL OVERRIDE SHORELINE WHEN THE GENERATOR IS OPERATING. FOR DETAILS OF THE AUTOMATIC SWITCHOVER RELAY SEE DWG. 952459.

ITEM	PART NUMBER	DESCRIPTION	QTY	UM
TOLERANCES				
±				
NEXT ASS'Y				
TITLE	110V., 50 AMP. Lay-out			
SCALE	DATE	DRAWING NUMBER	REV	
1/32	03/11/94	952493	B	
PRODUCT LINE		APPROVED BY		
33' L/Y MH.		T.C.		
DRAWN BY				
Airstream				

NOTES

APPLIANCES

AIR CONDITIONER

Manufacturer: Dometic Sales Corporation
2320 Industrial Parkway
P.O. Box 490
Elkhart, IN 46515
Phone: 219-295-5228

Note: Review the air conditioning literature supplied in your Owner's Packet before proceeding.

The roof air conditioner used on Airstream motorhomes is one of the most popular on the market today. In your Owner's Packet is a set of literature covering all operating and maintenance instructions. If the literature is misplaced, please contact the air conditioner manufacturer or your Airstream dealer for replacement. A detailed service guide may be ordered from the manufacturer.

Because of the amount of power drawn by the air conditioners, it is only possible to operate one at a time when plugged into city power. A wall switch, located above the kitchen counter, allows you to operate either the front or rear air conditioner, but not both at the same time.

Another appliance drawing a lot of current is the microwave. Operating the microwave and an air conditioner at the same time will put your electrical system at the edge of maximum draw. If the air conditioner goes into a "start up" cycle, the additional current will probably cause your main circuit breaker to kick out. If this situation occurs it is best to leave the air conditioner off for the few minutes the microwave is normally operated.

Both air conditioners may be operated when the generator is running or if you have optional 50 amp service. Set the priority switch to the front air conditioner and it is powered through the normal circuit. The generator powers the rear air conditioner through a separate circuit.

The voltage to the air conditioner is critical. We commonly refer to 110 or 120 volts, but a check with a volt meter may find voltage much lower. Your air conditioner will probably not function if the current drops below 105 volts. Low voltage is usually associated with older or poorly maintained trailer parks, but many people have found their homes, built only twenty or thirty years ago, may not be capable of operating the air conditioner on some receptacles. Parking your motorhome so the power cord can be plugged into a receptacle close to the fuse or circuit breaker box can alleviate the problem. Avoid extension cords and adapters whenever possible. If an extension cord must be used, it should be as short and heavy as possible to provide the most current to the air conditioner.

If high temperatures are expected, you should make an effort to park in a shaded area. Starting the air conditioner early in the morning also helps. It is much easier to hold a comfortable temperature than it is to lower the temperature after the interior of the motorhome is already hot.

FURNACE

Manufacturer: Hydro Flame Corporation
1874 South Pioneer Road
Salt Lake City, UT 84104
Phone: 801-972-4621

The manufacturer of the furnace in your motorhome has been well known in the RV industry for many years. The furnace burns LP gas, and is powered by 12 volt current from the battery or power converter when plugged into city power. Operating instructions are located in your Owners Packet. If they should become misplaced new literature can be ordered direct from the manufacturer or your Airstream dealer. The manufacturer also offers a detailed service guide for your furnace.

WARNING: Carefully read all the manufacturer's instructions prior to operating. NEVER store flammable material next to the furnace.

If warranty service is required use only a service location recommended by the furnace manufacturer or your Airstream dealer.

REFRIGERATOR

Manufacturer: The Dometic Corporation
2320 Industrial parkway
P.O. Box 490
Elkhart, IN 46514
Phone: 219-295-5228

In an absorption refrigerator system, ammonia is liquefied in the finned condenser coil at the top rear of the refrigerator. The liquid ammonia then flows into the evaporator (inside the freezer section) and is exposed to a circulating flow of hydrogen gas, which causes the ammonia to evaporate, creating a cold condition in the freezer.

The tubing in the evaporator section is specifically sloped to provide a continuous movement of liquid ammonia, flowing downward by gravity through this section. If the refrigerator is operated when it is not level and the vehicle is not moving, liquid ammonia will accumulate in sections of the evaporator tubing. This will slow the circulation of hydrogen and ammonia gas, or in severe cases, completely block it, resulting in a loss of cooling.

Any time the vehicle is parked for several hours with the refrigerator operating the vehicle should be leveled to prevent this loss of cooling. The vehicle needs to be leveled only so it is comfortable to live in (no noticeable sloping of floor or walls).

When the vehicle is moving the leveling is not critical as the rolling and pitching movement of the vehicle will pass to either side of level, keeping the liquid ammonia from accumulating in the evaporator tubing.

OPERATION

The refrigerator requires 12 volt current to operate even if running on LP or 110 volt modes. The 12 volt is used to power the circuit board that directs the refrigerator functions. When running in a mode such as LP, it means the heat source, by far the largest power requirement, to evaporate the ammonia is being provided by an LP gas burner.

WARNING: Most LP gas appliances used in recreational vehicles are vented to the outside of the vehicle. When parked close to a gasoline pump, it is possible that gasoline fumes could enter this type of appliance and ignite the burner flame, CAUSING A FIRE OR AN EXPLOSION.

RANGE AND OVEN

Manufacturer: Maytag Customer Service
Maytag Customer Assistance
P.O. Box 2370
Cleveland, TN 37320-2370
Phone: 1-800-544-5513

People using gas ranges in their home will find little difference in the operation of the range in the motorhome. Other customers, used to electric ranges may be a little apprehensive at first; but will quickly gain confidence. The basic operation of the gas ranges have been the same for many years, but please be sure to read all the directions furnished by the manufacturer and located in the Owner's Packet. Excellent service and parts manuals are available from the manufacturer.

WARNING: The operation manual for the range is titled "Maytag RV Cooking Appliances". If this has not been provided with your trailer, contact the manufacturer listed at the top of the page to obtain. Their manual contains specialized warnings and cautions that should be reviewed prior to operating the appliance.

MICROWAVE OVENS

Only federally certified technicians are permitted to service microwave ovens. For this reason the only service instructions contained in this manual are for removal of the complete oven. If you have a microwave problem please contact the appropriate manufacturer.

Magic Chef
28812 Phillips Street
Elkhart, Indiana 46514
219-264-9578

Sharp Electronics Corporation
10 Sharp Plaza
Paramus, New Jersey 07652
201-5112-0055

Litton
2530 North 2nd Street
Minneapolis, Minnesota 55411
605-336-5377

Quasar
Division of Matsushia Elec. Corp
1325 Pratt Blvd.
Elk Grove Village, IL 60007
201-348-9090

Airstream has used two different methods of holding the ovens in place. The most common is a set screw configuration where two bolts apply downward pressure on top of the range. The bolts can be found in the cabinet directly above the oven, and out toward the front. Back them out a few turns and the front of the oven can be lifted up and out over the lower ledge.

The second method was to slide a piece of 3/4" pine board under the microwave in front of the rear supports. Once in place screws were run up through the bottom shelf into the 3/4" pine.

You will note neither method makes any holes in the microwave cabinet. The microwave is simply captured in its cabinet. Usually you will be able to move the microwave around in the cabinet, but it won't come out.

WATER HEATER

Manufacturer: Atwood Mobile Products
4750 Hiawatha Drive
P.O. Box 1205
Rockford, Illinois 61105
Phone: 815-877-7461

Note: Review the water heater literature supplied in your Owner's Packet before proceeding.

CAUTION: Hydrogen gas can be produced in a hot water system served by this heater that has not been used for a long period of time (generally two weeks or more). Hydrogen gas is extremely flammable. To reduce the risk of injury under these conditions, it is recommended that the hot water faucet be opened for several minutes at the kitchen sink before using any electrical appliance connected to the hot water system. If hydrogen is present there will probably be an unusual sound such as air escaping through the pipe as the water begins to flow. There should be no smoking or open flame near the faucet at the time it is open.

Electronic Ignition

The switch used to light your electronic ignition water heater is located in the bathroom above the lavatory top. When the switch is turned on, the red light will come on indicating the "try" mode is in effect. Normally the burner will ignite in just a few seconds, and the light will go out. If your LP system hasn't been used for some time, the system may go into safety lock-out (about 20 seconds) before the air is all expelled from the lines. Turning the switch off for 30 seconds, then back on, reinstates the "try" mode. (See Note below.)

110 Volt Operation

In the bathroom you'll see a 110 volt switch for the water heater. This provides power to the heating element. **DO NOT** use unless you are sure the water heater is full. (open a faucet and see if there is a full stream of water on the hot side)

The 110 volt element may be operated at the same time as the gas burner. To operate the 110 volt by itself simply turn the electronic gas ignitor switch off.

The heating element is 1500 watts so if breakers start to kick out when the air conditioner cycles you may want to turn the switch off to the heating element.

Note: A complaint sometimes received at Airstream is the fact the water heater will not light for a while when the motorhome is first parked. The explanation is easy. The water is already hot! The motorhome water heater has a heat exchanger plumbed into the engine radiator system. As you are driving the water is being heated without your having to do a thing.

SAFETY

If your water system is full and cold and the water heater is ignited the system can see pressures as high as 160 psi before the relief valve starts to open. Since the water system normally operates in the 40 psi range the water expanding does pose unusual stress on the system. This normally does not cause any problems, but the stress is easily alleviated. As the water is heating just open any faucet and run as little as a cup of water. Just removing this small amount of water reduces the pressure build up significantly.

For fun watch the sequence of events your family goes through when you park the motorhome and ignite the water heater. More than likely someone will run water and relieve the pressure without even realizing it.

HIGH VOLUME ROOF VENT (OPTIONAL)

Manufacturer: FAN-TASTIC VENT CORP.
4349 S. Dort Hwy.
Burton, MI 48529
1-313-742-0330
1-800-521-0298

The optional high-volume roof vent system is designed to quickly exhaust stale, hot air and draw in fresh air. It's great to use when the outside temperature really doesn't call for air conditioning, but heat has built up in your coach.

OPERATING INSTRUCTIONS:

1. Rotate 3 speed switch to desired position, 0-off, 1, 2, and 3. The 3 speed switch must be set at 1, 2 or 3 to activate appliance.
2. Rotate thermostat knob toward 40° (cooler) until dome begins operating.
3. When equipped with reverse switch, there is a neutral (off) position. Fan motor will not operate when in/out switch is in its center "off" position. The dome will, however, operate up and down automatically as long as the 3 speed switch remains on.
4. To determine desired temperature setting;
 - a. Use the wall thermometer on furnace thermostat, or any interior temperature indicator.
 - b. Operate fan until interior comfort level is achieved. Rotate thermostat knob toward 110° symbol on label until dome begins closing. You now have the location for normal setting.

The thermostat sensor is calibrated approximately 4°. The minimizes rapid recycling of the unit, once desired temperature level is achieved.

5. The rain sensor built into your fan will prevent excessive rain from entering coach through open dome. Maintain a setting above (to the right of) "rain override" zone and dome will close when sensor becomes wet.

WARNING: Do not leave coach unattended with thermostat knob set in the "rain override" zone.

6. A rain sensor override is built into this system so you can operate your fan during light to moderate rains. When sensor is wet, rotate fan thermostat knob to coolest position to override sensor. Dome will open and fan motor will start. When sensor has completely dried, rotate thermostat knob back to desired setting for automatic operation.
7. To close dome in extremely hot conditions, rotate thermostat knob right, past 110° symbol to off. Dome will come down.
8. Always allow dome to completely cycle up and down. If dome "hangs up" in partially open/close position, rotate thermostat knob to extreme right and then left position allowing complete cycles down and up. Now reset to original comfort level.
9. When vehicle is in storage, rotate thermostat knob to right (off), after dome closes, turn 3 speed switch to "O" (off).

CLEANING INSTRUCTIONS:

- 1) Turn fan motor OFF.
- 2) Remove 8 painted flathead phillips screws around perimeter of screen insert only.
- 3) Clean screen with soap & water solution and reinstall.

SPECIFICATIONS

NOTE : All weights and measurements were made on prototype vehicles. Your production motorhome may vary slightly.

	30 FT	33 FT
DIMENSIONS		
Exterior Height with Air Conditioner	122"	122"
Interior Head Room	79"	79"
Interior Width	90"	90"
Exterior Length	31'2"	33' 5"
CAPACITIES		
LPG Tank	90 lbs.	105 lbs.
Fresh Water Tank	60 Gal.	60 Gal.
Grey Water Holding Tank	36 Gal.	36 Gal.
Black Water Holding Tank	34 Gal.	29 Gal.
Fuel Tank	75 Gal.	75 Gal.
CHASSIS COMPONENTS		
Wheel Base	190"	208"
Front Air Bags, Chevrolet	70 psi	70 psi
Tire Pressure, All	65 psi	65 psi
Tire Size, All	225/70x19.5	225/70x19.5

INDEX

- Air Conditioner.....C-2, I-1, J-1
AlignmentC-7
Antenna.....H-34, H-37
Appliances.....J-1
Automotive FusesH-2
Auxiliary Heater.....C-6
Auxiliary Start SwitchB-4, H-2
- BatteriesH-1
Black-Tank Flush.....G-11, G-31
Bottled GasG-1
- Cab Seats.....B-5
Camping.....D-1
Capacities.....K-1
Carbon Monoxide Alarm.....D-5
CarpetF-3
CautionIntroduction
ChairsF-1
ChassisC-1
Circuit Breakers.....I-1
City Hook-UpC-10
Cleaning Codes.....F-2
Cleaning, ExteriorE-1
CondensationD-9
Control PanelH-29
Counter Areas.....F-3
CurtainsF-3
- Dash Air Conditioner.....C-2
Dash InstrumentsB-4
Dimensions.....K-I
DinetteF-1
Door LockB-4, E-1
Drain Hose.....D-10, G-31
Drain LinesG-25
Drain Valves.....G-20
Drapes.....F-3
DrivingB-1
- Electrical SystemH-1
Electric StepC-11
Exhaust, Bath.....H-1
Exhaust, RangeH-29
Extended StayD-10
Exterior.....E-1
- FaucetsG-13
Fabrics, Cleaning.....F-2
Filter, WaterG-12
Fuel Filter.....C-6
Fuel PumpC-6
Fuel System, Chevrolet.....C-6
Furnace.....J-2
FusesH-2
- Gas, LPD-6, G-1
Gauges.....B-4
Generator.....B-4, D-10, I-1
Ground Fault Interrupter.....I-1
GVWRB-1, C-6
- Hardwood FlooringF-3
HeaterC-2
Hitch LoadB-5
Holding Tanks.....H-32
HumidityD-9
- Inflation Pressure.....C-6, K-1
Interior.....F-1
Inverter.....B-4
IsolatorH-2
- Keyless EntryE-3
- Lavatory, CleaningF-4
Leveling.....D-8, D-10
Leveling JacksD-8
Lights, InteriorB-4, H-1
LocksE-1
LoadingB-1
LoungeF-1
LP Gas Detector.....D-6
LPG System.....G-1
Lug NutsC-7
- Maintenance ScheduleA-7
Microwave OvensJ-4
Monitor PanelG-30, H-29
- Overnight Stop.....D-8

Plastics, Cleaning	F-4	Upholstery	F-2
Plumbing.....	G- 1	Vent, Power	J-6
Power Seats.....	B-5	Ventilation	J-6
Range/Oven.....	J-4	Walls.....	F-4
Refrigerator	J-3	Washing/Waxing	E-1
Roof Ladder	E-4	Warning	Introduction
Roof Vent	J-6	Warranty	A-1, A-4
Safety Defects, Reporting.....	A-6	Warranty Transfer	A-3
Safety.....	B-2, D-1, G-2	Warranty Exclusions	A-4
Seat Belts	B-3	Water Filter	G-12
Service	A-5	Water Heater.....	C-6, J-5
Sewer Hose.....	D-8, G-31	Water Hookup.....	D-10, G-11
Shades.....	F-3	Water Pump	G-6
Shorts and Opens.....	I-2	Water Strainer	G-6
Shower Stall	F-4	Water System	G-5
Sinks	F-4	Water Valves	G-20
Smoke Alarm	D-1	Weighing	B-1
Sofa	F- I	Wheel Base	K-1
Solar Power.....	H-37	Winterizing	G-28
Specifications	K- 1	Winter Traveling.....	D-9
Step, Electric	C-11	Wiring, 12 Volt.....	H-1
Switch Over Box	I-2	Wiring Diagrams, 12 Volt.....	H-4
Table	F-1	Wiring, 120 Volt.....	I-2
Tank Capacities.....	K-1	Wiring Diagram, 120 Volt.....	I-3
Tank Drain	G-31		
Tank, Holding	H-32		
Tank, Sewage.....	G-30, G-31		
Tank, Water	G-5		
Tank, LPG.....	G-1		
Tires	C-6		
Air Pressure	C-6, K-1		
Changing	C-7		
Rotation	C-8		
Support	C-9		
Torque.....	C-7		
Toilet.....	G-21		
Towing	B-5		
TV Antenna	H-34		
TV Monitor.....	D-8		
Tub/Shower	F-4		

