

'71 AIRSTREAM

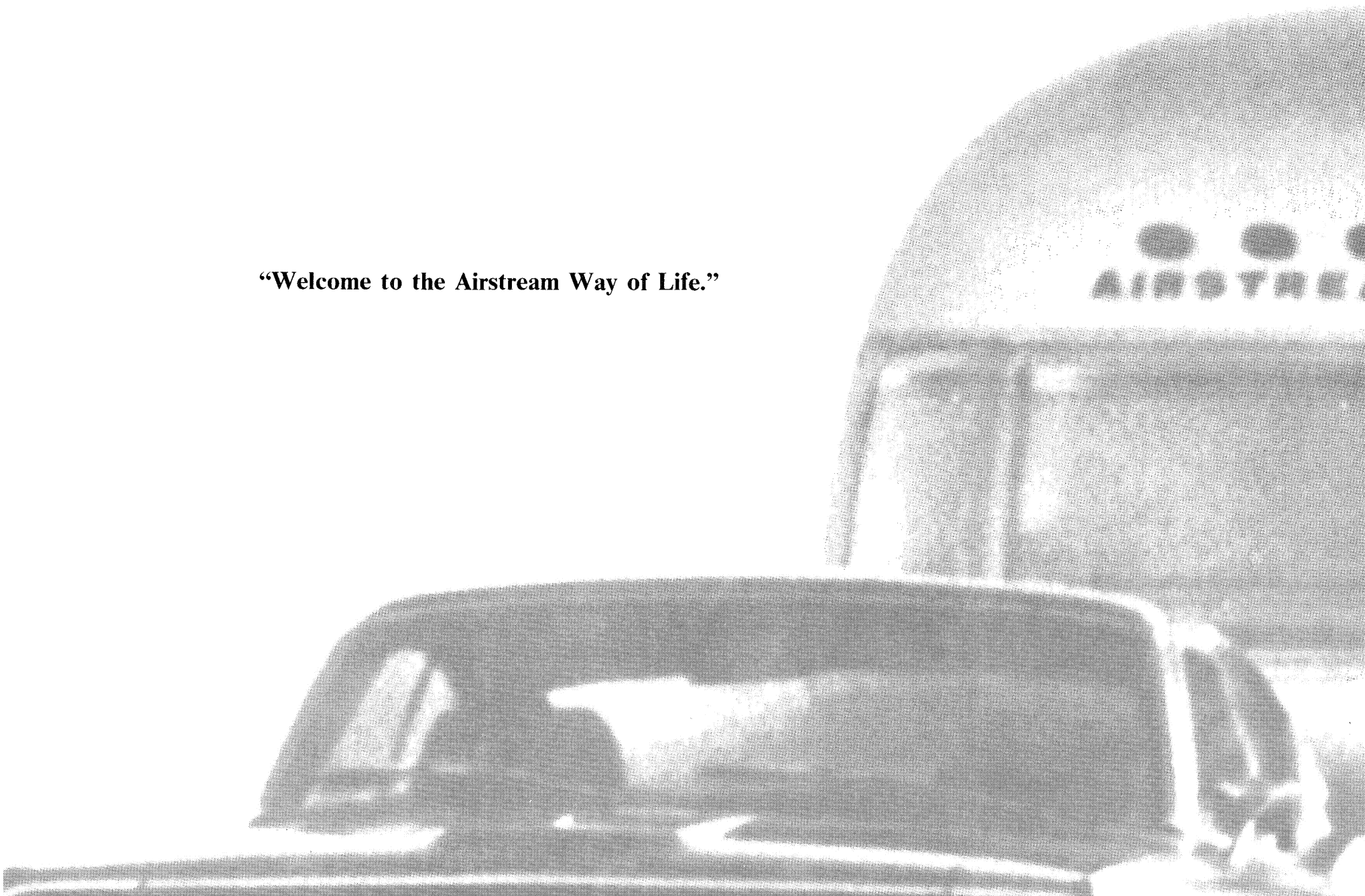

OWNERS

“Welcome to the Airstream Way of Life.”



This manual is your key to carefree travel fun. It contains the information you need to avoid problems. Please pass it on if ever you sell your Airstream.

The table of contents lists sections by letters and following this section letter, are the page numbers dealing with information in that particular section.

TABLE OF CONTENTS

A	1-2	WALLY BYAM CARAVANS AND CLUBS
B	3-6	AIRSTREAM WARRANTY AND FACTORY SERVICE
C	7-8	EQUIPPING TRAILER FOR THE ROAD AND WALLY BYAM STORES
D	9-10	HITCHING UP
E	11-13	TOWING TIPS
F	14-18	OVERNIGHT STOP-EXTENDED STAY AND LEVELING TRAILER
G	19	WINTER AIRSTREAMING
H	20	TRAILER STORAGE AND WINTERIZING
I	21-22	CHASSIS, RUNNING GEAR AND TIRES
J	23-24	EXTERIOR SHELL
K	25-27	INTERIOR
L	28	L.P.G. SYSTEM
M	29-37	APPLIANCES – REFRIGERATOR RANGE OVEN HEATER WATER HEATER
N	38-39	WATER SYSTEM
O	40-42	DRAINAGE AND VENT SYSTEM
P	43-48	ELECTRICAL SYSTEM
Q	49-50	OPTIONS
R	51-56	SPECIFICATIONS

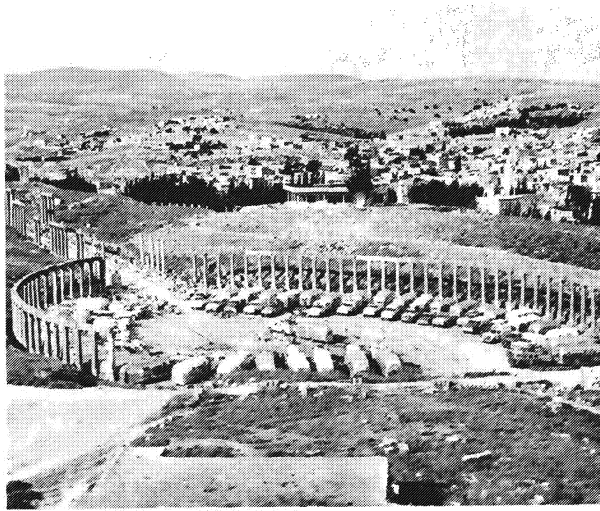
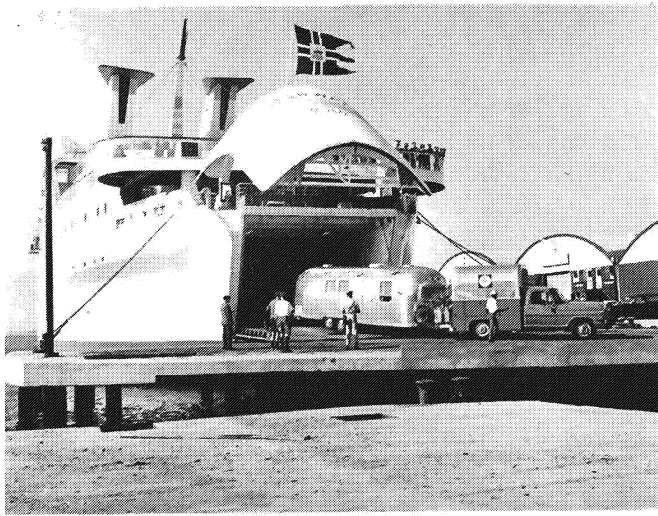

A 1-2 WALLY BYAM CARAVANS AND CLUBS

When you bought your Airstream, you bought a whole new way of life. Airstream owners enjoy endless opportunities for friendship, fun, and adventure. You may join every **Airstream Wally Byam Caravan** and **Airstream Company rally**. We arrange four such rallies each year: one in the North West, South West, North East, and South East. You also become eligible to join the **Wally Byam Caravan Club International**, the largest single make trailer club in the world. The **WBCCI** is made up of 20,000 family memberships and 114 local chapters or units throughout the United States, Canada, and Mexico. They meet at monthly rallies, or where weather conditions prevent year round rallies, Caravanners come together for pot luck dinners to plan events for the good seasons.

Since the first Wally Byam Caravan in 1951, 75 Airstream Caravans have gone to most parts of the world. Caravans to Canada and Mexico are now so popular that there are eight each year.

Old timers and new owners share experiences, and find a new kind of fellowship. Many a lifelong friendship was started on these trips, and there is no better way to learn to use your Airstream. Caravanners enjoy many advantages: the security of traveling in

a group, planned entertainment, and exceptional sight-seeing opportunities. The prestige and good will established over many years by our Caravans adds further benefit to Caravanner membership.

The “**Caravanner**” and the “**Blue Beret**” are the official Caravan Club publications. The bi-monthly “**Caravanner**” is for general distribution to owners and prospective buyers, while the monthly “**Blue Beret**” is for WBCCI members only.

Several months before a Caravan rolls, the “**Caravanner**” and the “**Blue Beret**” publish the itinerary and a registration coupon. Everyone who registers receives a detailed bulletin with complete information on the Caravan. When going abroad, all official matters, such as insurance, tourist cards, and border crossing formalities are handled for you by the **Caravan Staff**.

On every Airstream Caravan, the route is carefully planned, and a day to day itinerary, including mail stops, is given to all Caravanners in advance. Our staff also makes all the arrangements for parking, entertainment, tours, etc. well ahead of the starting date. Airstream Caravan Programs always take caravanners of all ages



into account. Airstream provides the Caravan Staff: a leader, a recreation director, a service representative, and an advance representative. This staff is backed by committees composed of interested Caravan members who assist in the day-to-day operations.

Wally Byam, pioneer trailer traveler, and founder of the Airstream Company, was born on July Fourth and the first **International Rally** was in the form of a huge birthday party for him at Bulls Shoals, Arkansas. It was patterned after the International Rallies in Europe which Wally and his wife Stella had attended for many years. Everyone enjoyed this first big rally so much that the club decided to make it an annual event. Since then, International Rallies have grown and grown. Some 2211 Airstream Travel Trailer families recently gathered at Grand Island, Nebraska with a total of more than 8,000 people. The site of the next summer International Rally is announced in an early fall issue of the "Caravanner" and the "Blue Beret."

Only Wally Byam Caravanners and WBCCI members are entitled to have an official **Caravan Club Number** and be listed in the **Annual Directory**. The annual Directory has a section listing owners with parking facilities at home for fellow members, a schedule of all major rallies and Airstream Wally Byam Caravans for the year,

and announces the activities of the Ham Radio, C.B. Radio, Square Dance, and the many other WBCCI special interest clubs.

Along with the fun, Airstream owners recognize the need for better legislation, more and better overnight parking facilities, more sanitary stations, other travel conveniences, and so on. They are alert to adverse bills governing travel trailers and have achieved much through the actions of the strong **WBCCI National Legislative Committee**.

The **Way of Life Department**, of the Airstream Company, dedicates its full-time staff to improving the owners fun and makes use of all the information and experience gained by owners over the years to help develop even better Airstreams.

Become part of the Airstream way of life. Join our WBCCI activities and we believe you will enrich your life. Owners join through a local unit of WBCCI. All operate autonomously, elect their own officers, and fix their own dues. Annual International dues are paid with the unit dues at the time of application. These are at present: International dues, \$5.00 per trailer, and unit dues from \$1. to \$5. If you are interested, please write to the **WBCCI Headquarters Office: 15939 Piuma Avenue, Cerritos, California 90701**, and we will forward your letter to the unit nearest you.



B 3-6

AIRSTREAM WARRANTY AND FACTORY SERVICE

Airstream offers the most complete and explicit warranty in the industry. **Please read the facsimile overleaf carefully. As soon as the factory has received your signed check-out and acceptance sheet, a formal warranty is issued to you, together with an owner's identification card.** As soon as you receive your warranty, please attach it over the facsimile for safe keeping. **In order to qualify for service without charge under the Airstream Lifetime Warranty Program, your owner's identification card or warranty must be presented to the service representative.**

The **Airstream Certified Performance Check-out, or C.P.C.**, is an exclusive Airstream program. Before leaving the factory, each and every vital part of an Airstream is tested for performance. Each test is signed and certified by an inspector. After the Airstream arrives on your dealer's lot, all of these vital parts and systems are again tested. When you take delivery of your new Airstream, a factory-trained trailer expert personally gives you a complete check-out on the trailer.

C.P.C. does not stop here. After you have traveled with your Airstream for 1000 miles (or 60 days, whichever occurs first) you can make an appointment with any one of the 175 Airstream dealers or service centers for still another check-out of your trailer. At that time, a specified list of performance checks on your trailer

equipment will be conducted as well as remedial care of any deficiencies you have experienced since taking delivery. Detach the card overleaf when you take your Airstream for the 1000 mile check.

Please contact your dealer if you need service. Minor service and adjustments will be done by him. If necessary when an appliance is affected, he may suggest one of the relevant service and repair locations whose warranty covers appliances. Major service under your Airstream warranty is promptly given by the nation wide network of factory trained specialists at the Airstream authorized service centers listed on pages 5 and 6 of this manual. **All centers operate on an appointment basis for the utmost efficiency.** When you require service from the Airstream factory or a certified service center please contact the service manager for an appointment, and kindly inform him if you are unable to keep the appointment date or wish to change it.

Airstream factory service may be arranged by contacting the service manager:

Airstream, Jackson Center, Ohio 45344 . . . (513) 596-6129 or Airstream, 15939 Piuma Avenue, Cerritos, California 90701 . . . (213) 860-4411

Please place your Registered Warranty over this Facsimile within the blue line, the folded edge on top. There is a glue strip on the back for the purpose.



For the lifetime of the Registered Warranty Holder, or so long as he continues as the original owner of the Airstream Travel Trailer, Airstream warrants the metal shell, frame, axle and axle assembly to and including spindle (excluding shock absorbers) to be free from defects in material and workmanship; all other component parts, including shock absorbers (excluding tires and batteries) are likewise warranted for a period of two years from the date of purchase. Any warranty defects will be corrected without cost upon return of the trailer or defective part, to any Airstream factory or authorized Airstream service center.

This warranty is in lieu of all other warranties of merchantability or fitness expressed or implied, there being no warranties which extend beyond the description on the face hereof and expressly excludes conditions resulting from normal wear, accident, abuse, exposure or overload.

AIRSTREAM

Ohio factory: 177 West Church Street, Jackson Center, Ohio 45334
California factory: 15939 Piuma Avenue, Cerritos, California 90701



ALABAMA

Alabama Auto Carriage Company
2359 West Fairview
P.O. Box 1695
Montgomery, Alabama 36108

Camper City & Mobile Home Sales
7320 First Avenue, North
Birmingham, Alabama 35206

ARIZONA

Robert Crist & Company
2025 East Main Street
Mesa, Arizona 85201

RoVan Mobile Homes, Inc.
3528 North Oracle Road
Tucson, Arizona 85705

ARKANSAS

Fred & Jack Trailer Sales
10318 New Benton Highway (I-30W)
Little Rock, Arkansas 72209

CALIFORNIA

Bob Belknap Trailer Sales, Inc.
420 South Harbor Boulevard
Santa Ana, California 92704

Caswell Trailer Sales
950 West Foothill Boulevard
Claremont, California 91711

Coastline Trailer Sales
303 North Ventura Avenue
Ventura, California 93001

Haller Trailer Sales
15711 S. Lakewood Blvd.
Paramount, California 90723

Nelson's Trailer Sales
28001 Mission Blvd.
Hayward, California 94544

Ralph's Trailer Sales & Supply
1025 East Main
El Cajon, California 92021

Valley Trailer Sales
1650 El Camino Avenue
Sacramento, California 95815

COLORADO

Chisman Trailer Sales
2301 East Boulder Street
Colorado Springs, Colorado 80909

Denver Trailer Sales Inc.
11225 West 6th Avenue
Lakewood, Colorado 80215

CONNECTICUT

Wepawaug Trailers, Inc.
655 Bridgeport Avenue
Milford, Connecticut 06463

DELAWARE

Richard Rice Trailer Company, Inc.
601 South Dual Highway
Seaford, Delaware 19973

FLORIDA

Bell's Trailer Park & Sales
R. R. #4, Box 382
Highway 90, West
Tallahassee, Florida 32310

Cribb's Campers
5408 San Juan Avenue
Jacksonville, Florida 32210

Hess Trailerama
618 New Warrington Road
Pensacola, Florida 32506

Indian River Trailer Sales
5855 U. S. Highway #1
Cocoa, Florida 32922

C. J. Stoll, Inc.
5985 34th Street, North
U. S. 19
St. Petersburg, Florida 33714

C. J. Stoll, Inc.
825 U. S. 301 Boulevard East
Bradenton, Florida 33505

GEORGIA

C & M Vacation Trailers
9726 South Expressway
19 miles South of Atlanta
Jonesboro, Georgia 30236

ILLINOIS

Ted Christman Trailer Sales
1200 Bloomington Road, West
P. O. Box 851
Champaign, Illinois 61820

Robert Crist & Company
9100 South Stony Island Avenue
Chicago, Illinois 60617

Deluxe Mobile Home Sales
2800 West Farmington Road
Peoria, Illinois 61604

Hunter Sales Corporation
415 North Illinois Avenue
Carbondale, Illinois 62901

Mann's Trailer Sales
1600 North Main
Normal, Illinois 61761

Ray's Travel Trailer Sales, Inc.
7135 - 49 West Irving Park Road
Chicago, Illinois 60634

INDIANA

Berning Trailer Sales
5220 New Haven Avenue
Fort Wayne, Indiana 46803

Bert's Trailer Sales, Inc.
R. R. #3, Box 17 (East U.S. 20)
Michigan City, Indiana 46360

Bill's Trailerland Sales & Service Center
12th & Main Streets
Vincennes, Indiana 47591

Brown County Travel Trailers
R. R. 4
Nashville, Indiana 47448

Draper's Auto & Trailer Sales, Inc.
912 State Road 67 East
Anderson, Indiana 46013

Draper's Sales, Inc.
7829 West Washington
Indianapolis, Indiana 46231

IOWA

Bill Brown Trailer Sales
3700-3708 East 14th Street
Des Moines, Iowa 50313

Ace Fogdall, Inc.
Highway 218 at Rownd Street
Cedar Falls, Iowa 50613

Bob Laveine Trailer Sales
890 West Mt. Pleasant Road
West Burlington, Iowa 52655

KANSAS

Boulevard Trailers, Inc.
5617 West Kellogg
Wichita, Kansas 67209

KENTUCKY

Murphy Sales Company, Inc.
Winchester Road (U.S. 60W)
Mt. Sterling, Kentucky 40353

Murphy Sales Company, Inc.
Benson Road
Shelbyville, Kentucky 40065

LOUISIANA

Barrow's Inc.
7517 Chef Menteur Highway
New Orleans, Louisiana 70126

MARYLAND

B & J Trailer Sales
113 South Philadelphia Blvd.
Aberdeen, Maryland 21001

MASSACHUSETTS

Mosher Travel Trailer Center, Inc.
Blue Jay 4 Corners
Sutton, Massachusetts 01527

MICHIGAN

Bob Frank Trailer Sales, Inc.
1416 West Columbia
Battle Creek, Michigan 49015

J & M Trailer Sales
3425 North East Street
Lansing, Michigan 48906

Kolbe Trailer Sales
5785 East Eight Mile Road
Warren (Detroit), Michigan 48091

Mid-State Trailer Sales, Inc.
5103 Eastman Road
1/2 Mile South of I-75 on US 10
Midland, Michigan 48640

Northwoods Trailer Sales
G-6369 North Dort Highway
Mt. Morris, Michigan 48458

Warner Trailer Sales, Inc.
3098 West Huron Street
Pontiac, Michigan 48054

Woodland Travel Center, Inc.
5190 Plainfield Road
Grand Rapids, Michigan 49505

MINNESOTA

Hart Trailer Sales
Highway 71
Long Prairie, Minnesota 56347

Minnesota Trailer Sales, Inc.
11350 Highway 65, N.E.
Minneapolis, Minnesota 55433

Pioneer Trailer Sales
Highway 218, South
Box 12, R. R. No. 2
Austin, Minnesota

Benson's Trailer Sales
3231 Miller Trunk Highway
Duluth, Minnesota 55811

MISSOURI

Bill Thomas Camper Sales, Inc.
5217 North Lindberg Boulevard
Bridgeton (St. Louis), Missouri 63042

Kansas City Trailer Sales, Inc.
14817 South 71 Highway
Grandview, Missouri 64030

MONTANA

Oliver Trailer Sales
5124 Laurel Road
Billings, Montana 59101

Modern Equipment Company, Inc.
4025 10th Avenue, South
Great Falls, Montana 59401

NEVADA

Webb's Travel Trailers
295 Kietzke Lane
Reno, Nevada 89502

NEW JERSEY

South Jersey Travel Trailer Center, Inc.
Route 47
Franklinville, New Jersey 08322

NEW MEXICO

Gunn's Recreational Vehicles, Inc.
12020 Central Avenue, S.E.
Albuquerque, New Mexico 87112

NEW YORK

Atlantic Trailer Sales
1226 Fairport Road
Fairport, New York 14450

Callahan's Trailer Sales
R. R. No. 1, Route 15
Lindley, New York 14858

Carson Rotary Service
321 Bridge Street
Vestal, New York 13850

Eddy's Trailer Sales, Inc.
4005 Jericho Turnpike
East Northport, New York 11731

Maroone Family Travel Center, Inc.
2550 Walden Avenue
Exit 52, East of N. Y. Thruway
Buffalo, New York 14225

Niblack Trailer Sales
691 McLean Avenue
Corner N. Y. Thruway
Yonkers, New York 10704

O'Malley Enterprises, Inc.
P. O. Box 116
Traffic Circle, Rt. 9 & 7
Latham, New York 12110

NORTH CAROLINA

College Park
North Church Street Ext.
US 301 & 301A, North
Rocky Mount, North Carolina 27801

Faires, Inc.
3217 North Tryon Street
Box 5205
Routes 29 & 49
Charlotte, North Carolina 28206

Out of Doors Mart, Inc.
Drawer 799
Kernersville, North Carolina 27284

OHIO

Avalon Travel Center
11761 Portage Road
Canal Fulton, Ohio 44614

K & B Airstream Sales
8641 Mentor Avenue
Mentor, Ohio 44060

Macke Trailer Sales & Rental
1044-1108 East Spring Street
St. Marys, Ohio 45885

Marine Mart Trailer Sales
8750 Harrisburg Pike
16 miles S. W. Columbus on U. S. 62
Harrisburg, Ohio 43126

Murphy Travel Trailers of Ohio, Inc.
11526 Chester Road
I-75 at Howard Johnson
Cincinnati, Ohio 45246

P J Airstream Sales, Inc.
5247 Alexis Road
Sylvania, Ohio 43560

Richland Travel Trailers
302 Ashland Road
Mansfield, Ohio 44905

Frank B. Ricketts Mobile Homes-Travel Trailers
P. O. Box 583
Clark Street and Maple Road
Cambridge, Ohio 43725

State Trailer Sales
1715 North State Street
Girard, Ohio 44420

OKLAHOMA

Brassfield Mobilhomes
7207 N. W. 39th Expressway
Bethany, Oklahoma 73008

Jack Thurman
11311 East Admiral Place
Tulsa, Oklahoma 74115

OREGON

Cascade Trailer Sales
1876 Highway 99 North
Eugene, Oregon 97402

Comrie Trailer Sales
603 S. E. Court Avenue
Pendleton, Oregon 97801

Spencer Mobile Homes
9341 S. E. 82nd Avenue
Portland, Oregon 97266

PENNSYLVANIA

Farnsworth Camping Center
Route 54
Elysburg, Pennsylvania 17824

Turner Airstream Sales
412 Lincoln Highway, West
Jeannette, Pennsylvania 15644

Walter H. Glasgow
1650 Lincoln Way, East
Chambersburg, Pennsylvania 17201

SOUTH CAROLINA

Dixie Lee Trailer Sales
Highway U.S. 1 & 78
P. O. Box 306
Clearwater, South Carolina 29822

Skyway Mobile Homes
Box 262
U.S. 25 at 276
4 Miles N. of Greenville
Travelers Rest, South Carolina 29690

SOUTH DAKOTA

Capitol City Trailer Sales
801 North Euclid Avenue
P. O. Box 116
Pierre, South Dakota 57501

TENNESSEE

Campers, Inc.
1401 Central Avenue, North
Exit I-75 at Woodland
Knoxville, Tennessee 37917

Cullum & Maxey Sales & Servicer
160 McGavock Pike
Donelson (Nashville), Tennessee 37214

Tri-City Travel Trailer Sales
873 East Stone Drive
Bristol-Kingsport Highway, 11 West
Kingsport, Tennessee 37660

TEXAS

Abbott Trailer Sales
408 Avenue Q
Lubbock, Texas 79401

Baker Travel Trailers
4200 East Belknap
Fort Worth, Texas 76117

Land Yacht Trailer Sales, Inc.
4616 Titanic Avenue
El Paso, Texas 79904

Lloyd's Trailer Sales, Inc.
350 Twin City Highway
Port Neches, Texas 77651

South Texas Trailers & Supplies
Highway 77, South
P. O. Box 1051
Sinton, Texas 78387

Sportsman Travel Trailer, Inc.
7935 Gulf Freeway Exit 12
Houston, Texas 77017

Texas Trailercoach of Dallas, Inc.
Route 2, Box 28
Levittsville, Texas 75067

UTAH

Intermountain Trailer Sales
3776 Wall Avenue
P. O. Box 1503
Ogden, Utah 84401

VIRGINIA

American Trailer Sales Co., Inc.
7846 Richmond Highway
Alexandria, Virginia 22306

McGeorge Travel Center
6200 W. Broad Street
Richmond, Virginia 23230

Travel Trailers of Va., Inc.
P. O. Box 807
2211 South Main Street
Harrisonburg, Virginia 22801

WASHINGTON

Central Trailer Exchange, Inc.
14433 Pacific Highway, South
Seattle, Washington 98168

Don's Trailer Sales
E. 7217 Sprague Avenue
Spokane, Washington 99206

Tveten Motor Company
45th & Pacific Avenues
Tacoma, Washington 98408

WEST VIRGINIA

Don's Travel Trailers
459 Winfield Road
U.S. 60 at 17
St. Albans, West Virginia 25177

WISCONSIN

J & M Homes
1360 Velp Avenue
Green Bay, Wisconsin 54303

Mauston Home Sales, Inc.
101 Prospect Street, Highway D
Mauston, Wisconsin 53948

Northside Trailer Sales, Inc.
N56 W13180 Silver Spring Road
1 Mile W. of Highway 100
Silver Spring Road
Menomonee Falls, Wisconsin 53051

Sweet Trailer Sales
U. S. 51 and U. S. 2
Hurley, Wisconsin 54534

Wisconsin Mobile Homes, Inc.
4201 East Washington Avenue
Madison, Wisconsin 53704

CANADA

Totem Trailers, Ltd.
85 Plains Road, West
Burlington, Ontario, Canada

Travel Trailers Western, Ltd.
5804 - 104 Street
Edmonton 70, Alberta, Canada

Twin City Trailer Sales, Ltd.
P. O. Box 395
Dartmouth Highway
Bedford, Halifax Co., Nova Scotia

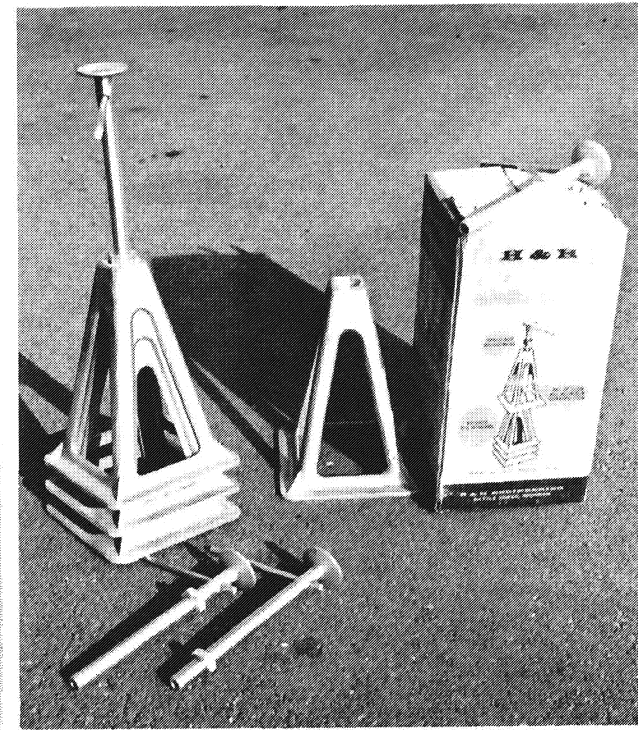

C 7-8 EQUIPPING TRAILER FOR THE ROAD AND WALLY BYAM STORES

To make trailering more enjoyable, there are now **Wally Byam Stores** at both Airstream factories and many authorized dealers throughout the United States, stocking hundreds of items tested and approved by travel experts. Be sure and get a **Wally Byam Store Catalog** from your dealer or the Airstream factory.

The following is a list of equipment we recommend:

1. First aid kit.
2. Tool box of small hand tools such as: screwdrivers, pliers, crescent wrench, etc.
3. Crosstye lug wrench for trailer wheels.
4. Hydraulic jack for trailer axle.
5. Four stabilizing jacks.
6. Spare tire for single axle trailers.
7. Fire extinguisher.
8. Two plastic pails for carrying water and a large funnel.
9. Four wheel chocks to fit against tires and prevent the trailer from moving while parked.
10. Two 50 ft. lengths of 5/8" high pressure water hose, and a 'Y' connection which enables two trailers to be hooked up to one faucet.
11. One six foot and one ten foot sewer hose and coupler.
12. 75 ft. electric cord with a 30 amp. capacity.
13. Small spirit level.
14. Flashlight.
15. Short handled shovel (G.I. type, Army surplus).
16. Cleaning equipment: broom, sponges, mop, etc.
17. Road emergency flares.
18. Spare 20 and 40 amp.-cartridge-fuses



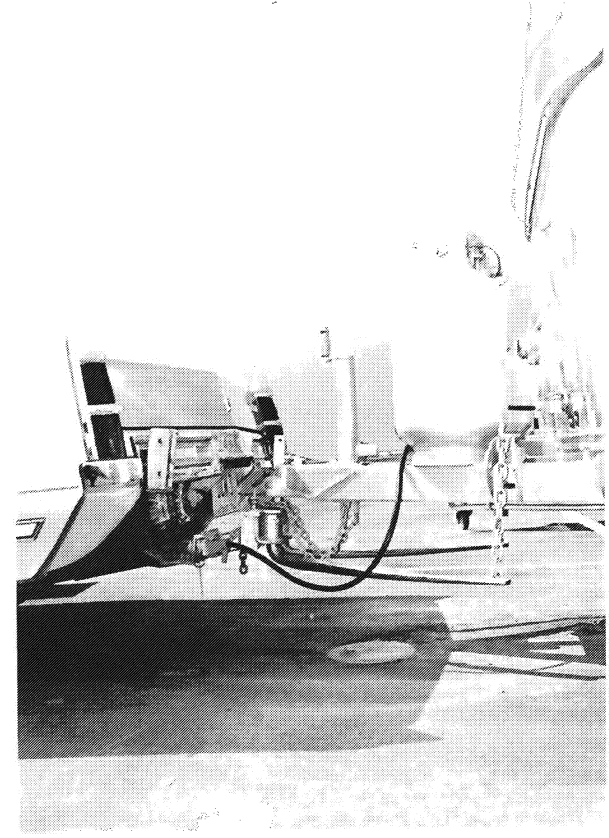
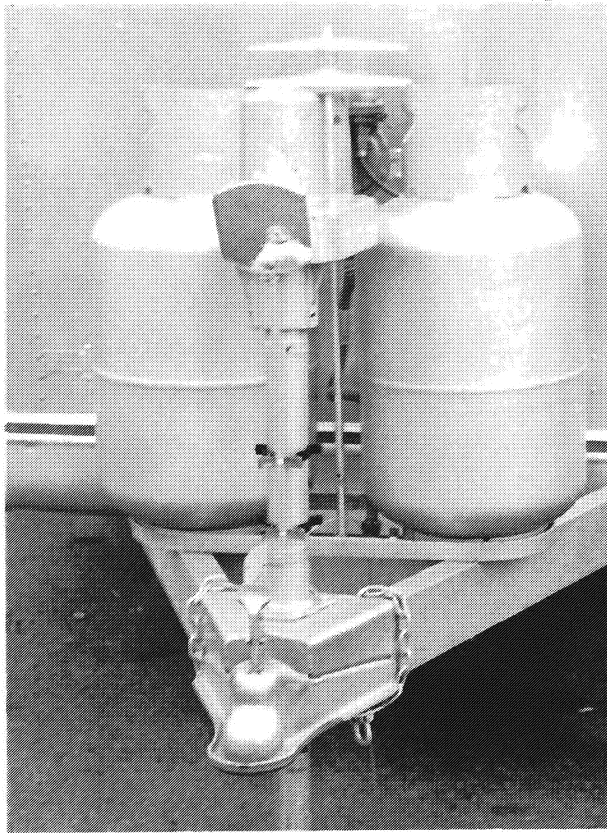

D 9-10 HITCHING UP

Hitching your Airstream trailer is something that will become almost second nature with practice, however, there are a few tips, learned from experience, which will help you.

1. Jack up the trailer hitch until there is clearance for the **hitch ball** to slide under, and raise the **locking lever**.
2. Back the car straight back to the hitch connection. This can be accomplished through the use of pre-arranged hand signals with the help of another person, but if you are hitching up by yourself, we recommend the use of a **hook-up view mirror**.
3. Lower the trailer **hitch coupler** onto the hitch ball then close the locking lever.
4. Jack up the trailer to the full height of the **hitch jack** and then

attach the **leveling bars**. The tension on the load leveling bars should be adjusted so that the attached hitch is about 1" higher than the car was alone. (see illustration) This will result in the best balance for towing and steering control as the **weight equalizing hitch** transmits the hitch weight of the trailer via the load leveling bars equally onto the trailer wheels and all four wheels of the car. A little practice with your rig will teach you how far to pull up the bars. Always choose level ground for checking correct hook-up.

Caravanner insurance statistics show that most accidents are the result of improper hook-up. The hitch ball on your car should be installed at a height of 19-1/2" to the top of the hitch ball.

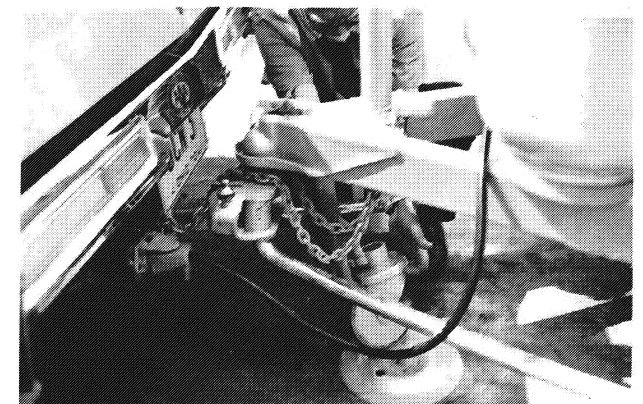
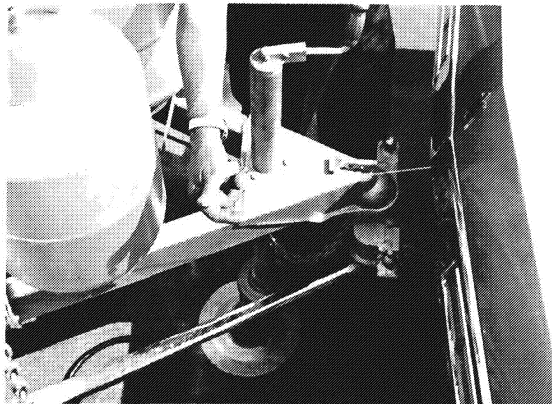
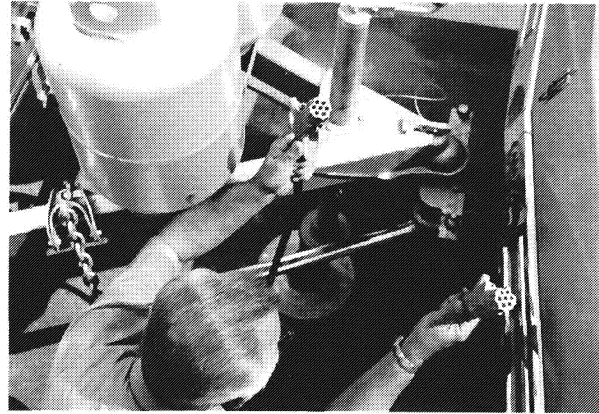
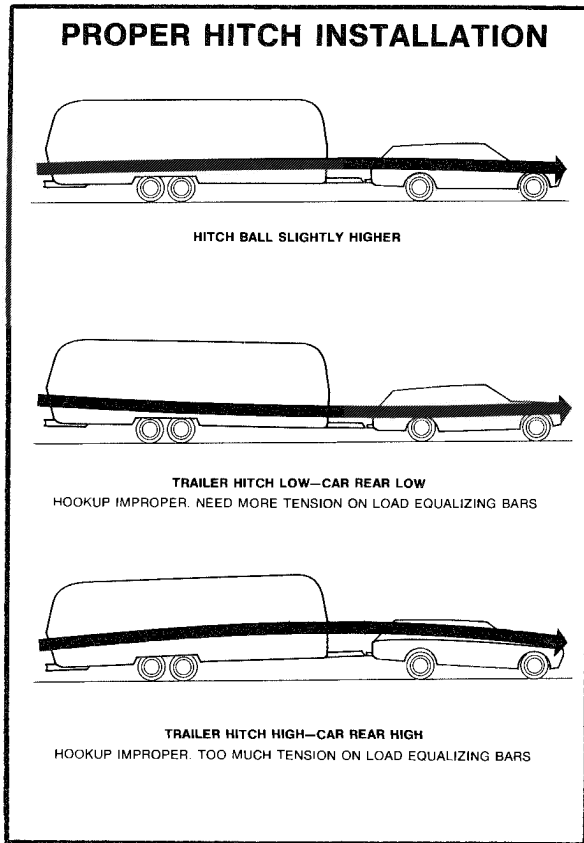

A low hitch ball increases tailwagging tendencies by lowering the nose of the trailer thus changing the center of support for the trailer and reducing the weight on the front wheels of the car.

5. Plug in the **electrical connector**, and check **running, directional, and brake lights**. The electrical connector should be completely removed and stored when not in use.

6. Attach the **break-away cable** and the **safety chains** to the welded portion of the hitch or the car's frame, but never to the removable ball mount.

7. Retract the hitch jack completely for maximum ground clearance. Remove the **dolly wheel** and **jack pad**, and stow them in the car's trunk or some other safe place. **Never tow your trailer with the jack down or the dolly wheel on. Check to be sure your main door is locked and the Fold-Away Step is up.**

8. Move the rig ahead about 50 feet and test your trailer brakes, then check the ground for forgotten objects. Regularly check the condition of your tires, air pressure, and the tightness of the lug-nuts. (For specific tire pressures and lug-nut torques refer to section "I"). Leveling jacks, blocks, and other tackle related to hitching up, should be put in your car's trunk and not stored in the trailer.

The majority of new trailerists carry more food and other supplies than really needed. Remember that every item you take along is one more thing to stow and adds weight to the total load you must pull. Consolidate items in shelves, lockers, and in the refrigerator. It is better to have one full and one empty locker than two half empty ones. Special care must be taken not to overload the front and rear ends of the unit.

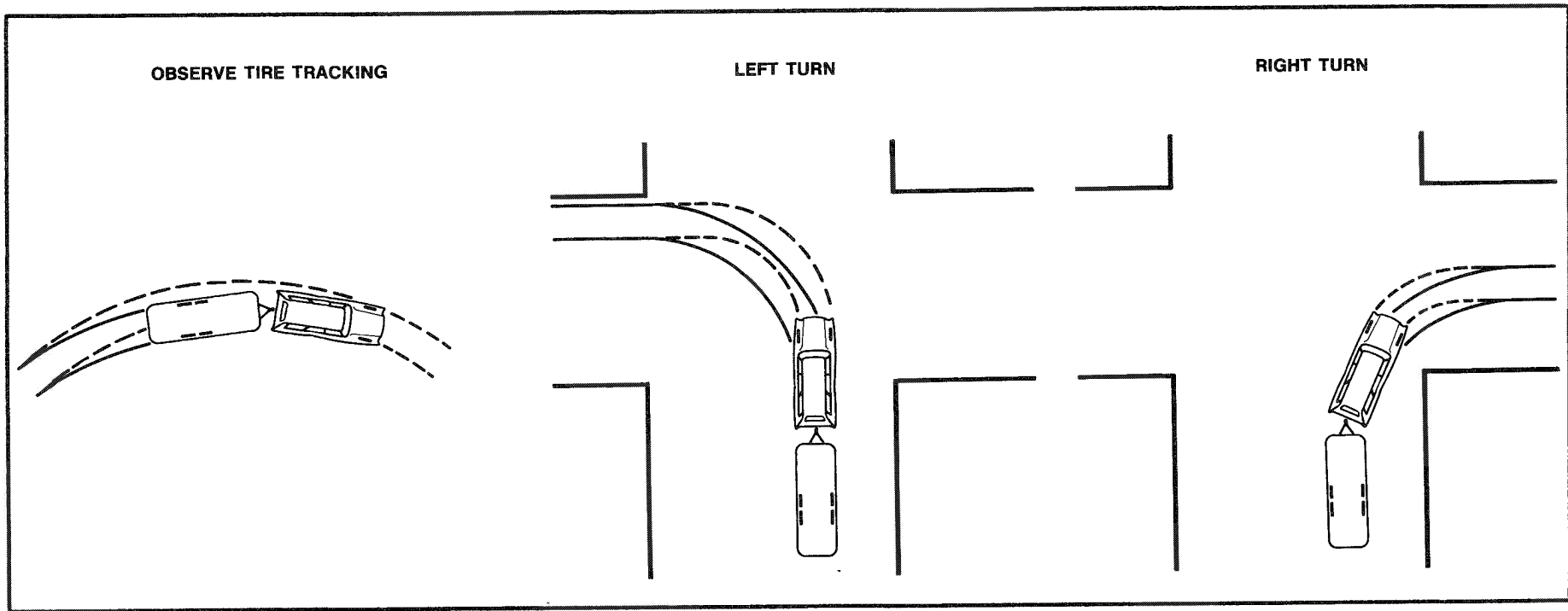

E 11-13 TOWING TIPS

A few hours of towing practice in a large empty supermarket parking lot will make towing your Airstream over the road much easier. Line out two corners for both left and right turns, and you may also use these corners to practice backing and parking. Observe that **the tracks made by your trailer wheels are distinctly different from those made by your car.** Studying this will make it easier for you to correct mistakes. Truck or trailer type **fender grip rear view mirrors** are a must for maximum visibility and in most States they are required by law.

You are now ready to tow. After checking the traffic, signal that you are about to pull away and start slowly. Look often in your mirrors, and observe the action of your trailer, then carefully move into the proper lane of traffic. Remember that the trailer wheels will not follow the path of your car's wheels, therefore, **wider turns**

are necessary when turning to the left or to the right.

On **freeways** or **expressways** try to pick the lane you want, and stay in it. Always maintain plenty of space between you and the car ahead, at least the length of your car plus trailer, for every ten miles per hour. Remember that in order to pass another vehicle, **you will need longer to accelerate.** You must also allow for the length of your trailer when returning to your lane. On a two lane road, cars will be lining up behind you because you travel at a lower speed. It is both courteous and sensible to signal, pull onto the shoulder, and let them pass. Your Airstream is designed to be towed at any legal speed, and it tows so easily that you may be inclined to forget it is even there, but remember, it is. **Your car brakes will automatically apply the trailer brakes first.** This will make you stop as if you were driving the car alone and keep your car and trailer in a straight line.



When driving up a long grade, **shift into a lower gear** well in advance of when your engine begins to labor. **Turn the air conditioner off** to help avoid overheating the engine. If your engine does overheat, pull off to the side of the road and keep it running at a fast idle. Never turn the engine off while the red light is on, and then only when it has been out for at least five minutes. A **trans-cooler**, which air cools the transmission fluid, will help prevent engine overheating, and the installation of a **temperature gauge** in addition to the indicator light is also a good idea.

When going downhill in dry weather, downshift so that engine compression will slow the whole rig down. Take dips and depressions in the road slowly, and do not resume normal driving speeds until you are sure the trailer is clear of the dip.

On slippery pavement do not use engine drag to help slow down as this may cause the rear wheels of the car to skid. On icy pavement drive slowly and if you feel the car is skidding, gently apply the

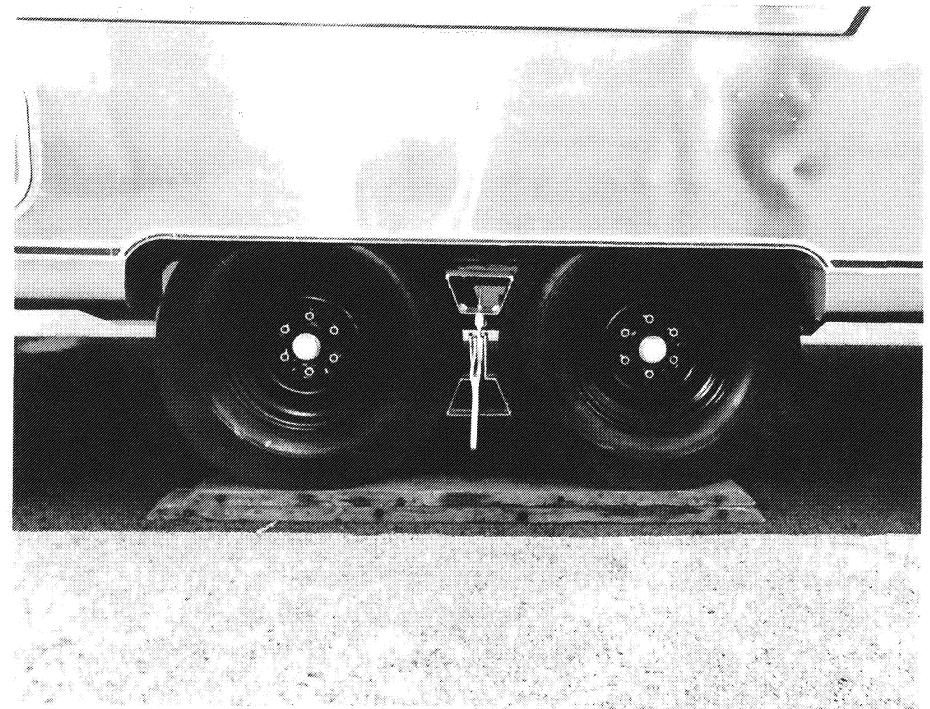

trailer brakes only. This will bring your car and trailer back into a straight line. Chains do not help trailer wheels.

When driving in mud and sand let your momentum carry the rig through. Do not depend too much on your drive wheel power. Stay in the ruts of the vehicle ahead and keep your car in the highest possible gear.

If you have to tow long distances over bad roads, the stones and gravel thrown back by your tires will dent and scratch the aluminum finish of your Airstream. To prevent this, use masking tape to secure heavy sheets of cardboard to the lower front end of the trailer.

When stopping on a hill or slope, leaving your car in gear is not enough for stand-still-safety. **Chock** the trailer wheels to be doubly sure. Never use the breakaway switch as a parking brake because it will burn out the magnet and drain your battery.

In backing up, the important thing to remember is to **do everything slowly** and to **correct immediately** if you see the trailer turning the wrong way. **Concentrate on the rear of the trailer.** With your car and trailer in a straight line, back up slowly and turn the bottom of the steering wheel in the direction you want the trailer to go. Watch out the window or in the mirror until the rear of the trailer is pointing in the desired direction. Then turn the steering wheel in the opposite direction. Your car will be following the trailer in an arc. Straighten the car and trailer by turning the steering wheel more sharply, then when they are in line, straighten the steering wheel. **Always try to back to your left because the visibility is much better.** (see illustration)

If you plan to buy a new car to tow your Airstream, we suggest that you include in your purchase the **trailer towing options** offered by most automobile manufacturers. These include such things as an oversized generator and radiator, heavy duty springs and shock absorbers, transmission cooler, oversized fan, and others, depending on the make of the vehicle.

Transmissions may be manual or automatic, but an **automatic transmission** will prolong your car's engine life and does a better job of controlling engine loads than the average driver using a manual shift.

The **weight to horsepower ratio** is very important when considering the purchase of a new car or the trailer towing capabilities of your present one. The practical upper limit for most road conditions is 60 lbs. per hp. Anything between 30-40 lbs. is considered optimal.

To work out your ratio, add the weight of the trailer to the advertised weight of your car, and divide by the advertised horsepower. For example: A 27 ft. Airstream weighing 4500 lbs. plus an automobile weighing 3600 lbs. would equal 8100 lbs. Dividing this weight by a rated 270 hp. for the car would result in 30.0 lbs. per hp., a figure well within the acceptable weight to horsepower ratio.

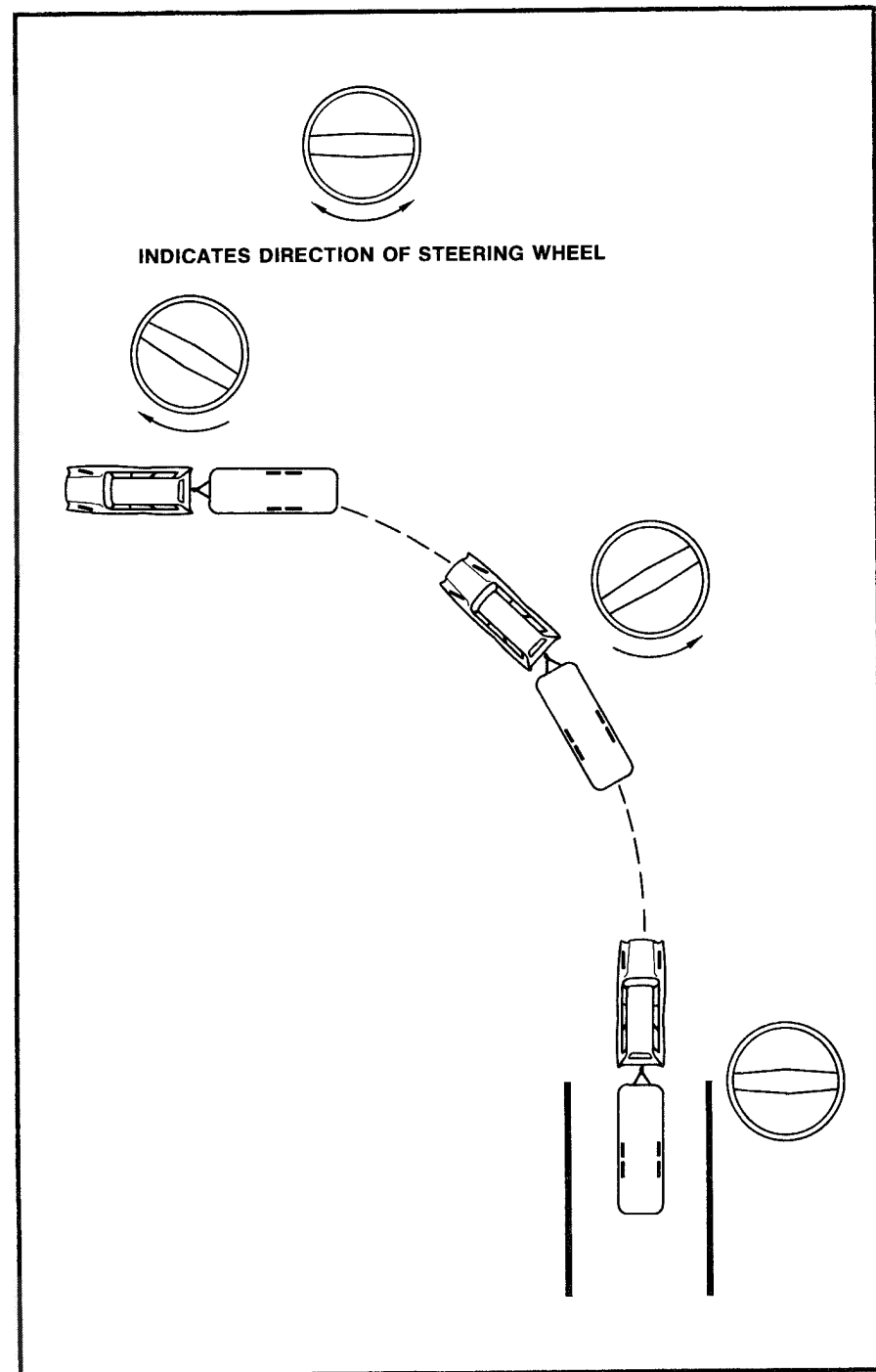



F 14-18 OVERNIGHT STOP-EXTENDED STAY AND LEVELING TRAILER

When stopping for the night your Airstream is built to be safely parked in any spot that is relatively level and where the ground is firm. Your facilities are with you, you are **self-contained**. Airstream owners have parked virtually every place imaginable from filling stations to farm lands, in driveways, etc. In time you will develop a knack for spotting wonderful little roadside locations by turning off the main highway and exploring. See the end of this section for some helpful state laws.

There are, of course, many modern trailer parks; State, County, and Federal parks with good facilities, where you may obtain hook-ups or outside sources of supply, such as electricity, water and sanitary dumping stations. Directories are published which describe in detail these parks and tell what is available in the way of services.

On overnight or weekend trips, chances are you will not use up the capacity of your sewage holding tank, deplete your water supply or run down the battery which supplies your 12 volt current. **On a longer trip**, when you have stayed where sewer connections and utility hook-ups were not available, it will be necessary for you to stop from time to time to dispose of the waste in your holding tank and replenish your water supply. Many gas stations (chain and individually owned) have installed **sanitary dumping stations** for just this purpose. Booklets are available which list these dumping stations.

In stopping for the night, unless the car is needed for transportation, it is not necessary to unhitch. Try to pick as level a parking spot as possible. **Stabilizing jacks** or **blocks** probably won't be required for an overnight stay; put the jack pad on the hitch jack and run

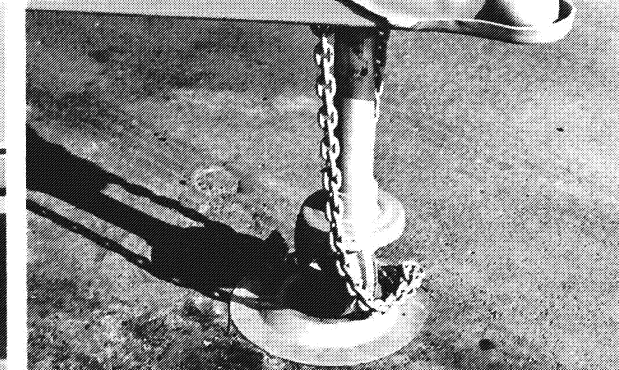
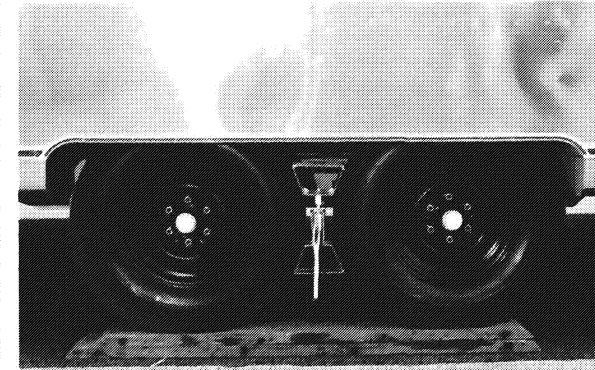
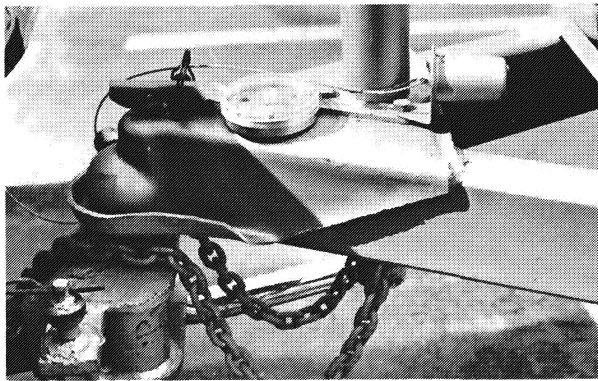
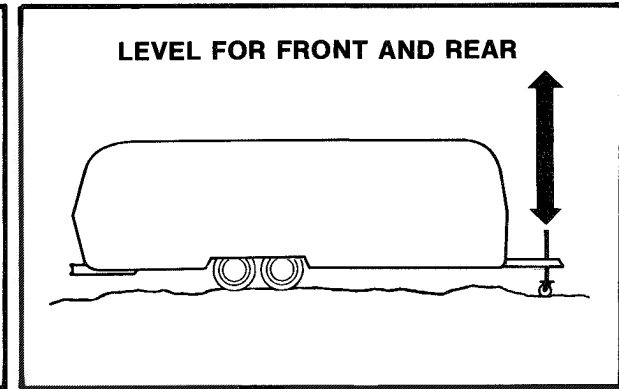
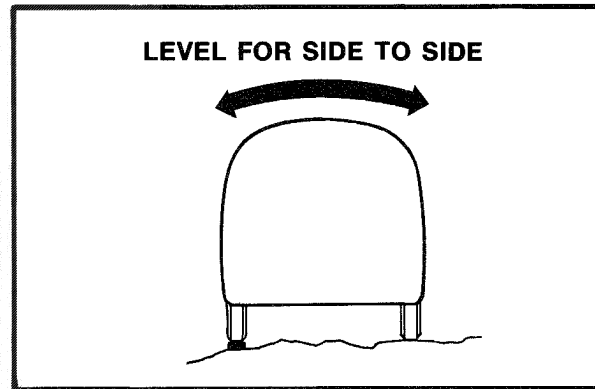
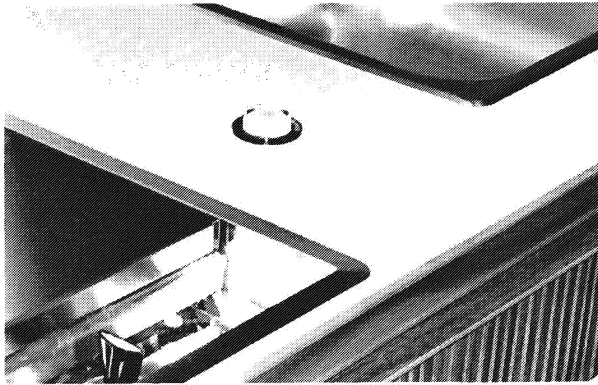

the hitch jack down to take the weight off the car's springs to provide stability. If you must park on a slope, **park facing down-hill**; it is easier to level the Airstream this way.

All you need to do to enjoy the self-contained luxury of your Airstream is to:

1. Light the water heater, refrigerator and furnace pilots if required. (See sections "L & M" for complete details on LPG system and gas operated appliances.)
2. Turn on the gas supply at the range.

Before moving on, be sure to check your campsite, both for cleanliness and to be sure you haven't left anything behind, turn off the gas supply petcock to the range and make sure everything is properly stowed. Use your Hitching Up check list (chapter D), and you are ready for more travel adventure.

Making a long trip in your Airstream is not very different from making a week-end excursion. Since everything you need is right at hand you are at home wherever you go. When packing for an extended trip take everything you need, but only what you need.

When you plan to stay in the same place for several days, weeks, or months, you will want your trailer to be as level and steady as possible. Check the attitude of your Airstream with a small **spirit level** set on the work counter of the "A-Frame" of the trailer. If a correction is necessary then you must **level from side to side first**. This can be done most easily by running the wheels on the low side up a small ramp consisting of 2"x6" boards about four feet long and tapered at both ends. (see photograph.) We do not recommend placing tires in a hole for leveling. Note: This same technique may be used to change a tire on a tandem unit.

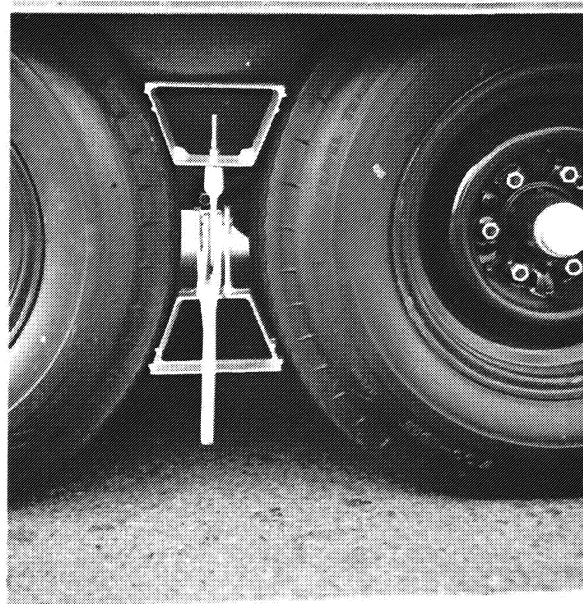
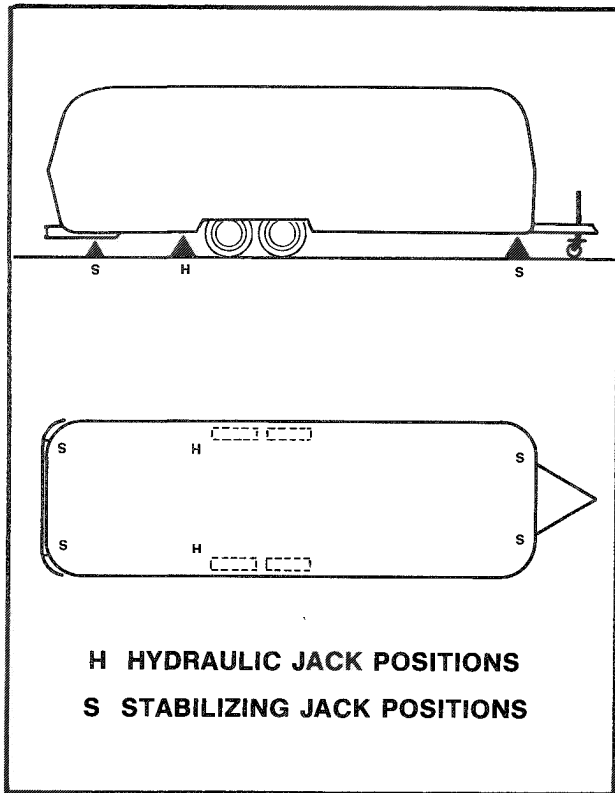

Level the front and rear by disconnecting the hitch, putting the jack pad under the hitch jack and adjusting the jack up or down until you are level. **Block or chock the wheels** to keep the trailer from rolling. Use stabilizing jacks at all four corners, as shown, to eliminate the natural spring action of the axles.

Note: Whenever the trailer must be lifted with a jack, as when changing a tire or leveling on very rough terrain, **always place the jack under the main frame rail**. A 3" aluminum pad is provided to indicate the proper position for the jack. **Never use stabilizing jacks to lift the trailer.**

Hook up to water by attaching a 5/8" high pressure water hose to the city water service.

Plug the **electrical cable**, which is stored in the **rear bumper com-**

partment, into the **city power service**. Be sure you have the wire **grounded** and have the proper **polarity**. (See section "P" for technical details.)

Hook your **waste drain hose** into the **sewer disposal facility** and attach to the **drain outlet** in your trailer. For details on this procedure refer to Section "O". Follow the same steps you would for self-containment and light gas appliances.

Travel trailering through our United States requires a knowledge of many state regulations. Here through the cooperation of Trailer Life Magazine, North Hollywood, California, is a brief summary of maximum speed limits, permissibility of making overnight stops on highways or roadside rest areas, and permissibility of keeping a dog in a state or county park. State laws may change from time to time so watch carefully for posted signs.

STATE LAWS

Trailer traveling through our United States requires a knowledge of many state regulations. Here through the cooperation of Trailer Life Magazine, North Hollywood, California is a brief summary of three of these regulations.

(1) Maximum Speed Limit of vehicles towing a trailer. (2) Permissibility of making Overnight Stops on highways or roadside rest areas. (3) Permissibility of keeping a DOG overnight in State or County parks.

NOTE: State laws may change after the printing of this manual. Watch carefully for posted signs.

ALABAMA

MSL: 70 mph days, 60 mph nights on open highway.
OS: Parking off highway is permitted.
DOG: Not allowed.

ALASKA

MSL: 50 mph.
OS: Permitted off highway.
DOG: Permitted in state parks at night.

ARIZONA

MSL: As posted.
OS: Permitted at roadside rest areas unless otherwise posted.
DOG: Permitted if leashed in state and county parks.

ARKANSAS

MSL: 50 mph.
OS: Permitted off highway unless posted.
DOG: Permitted if leashed in state and county parks.

CALIFORNIA

MSL: 55 mph.
OS: Permitted off highway
DOG: Allowed if leashed

COLORADO

MSL: 60 mph open highway, 40 mph open mountain highway.
OS: Permitted off highway.
DOG: Permitted if leashed in state and county parks.

CONNECTICUT

MSL: 60 mph, 70 mph on interstate or limited access highways.
OS: Generally not permitted.
DOG: Permitted if leashed in state and county parks, one pet per campsite. Not permitted on beaches at any time.

DELAWARE

MSL: 45 mph.
OS: Permitted off highway.
DOG: Allowed if leashed

DISTRICT OF COLUMBIA

MSL: 25 mph or as posted.
OS: Permitted off highway.

FLORIDA

MSL: On turnpikes, 70 mph. On interstate highways, 65 mph days, 60 mph nights. Other highways, 50 mph days, 45 mph nights.
OS: Permitted.
DOG: Daytime only on leash.

GEORGIA

MSL: 55 mph days, 50 mph nights.
OS: Permitted at roadside park or rest area if not posted otherwise.
DOG: Permitted in state and county parks.

HAWAII

MSL: Set by local ordinance.
OS: Permitted off highway.

IDAHO

MSL: 60 mph, 55 mph nights.
OS: Permitted in roadside parks or rest areas unless posted otherwise.
DOG: Permitted in state and county parks if leashed.

ILLINOIS

MSL: 55 mph. Pickups over 8000 lbs. towing trailer, 50 mph.
OS: Not permitted.
DOG: Permitted in state parks if leashed.

INDIANA

MSL: 65 mph. 70 mph on interstate highways.
OS: Not permitted.
DOG: Permitted if licensed and attended.

IOWA

MSL: Trailer under 4500 lbs., 55 mph. Trailer over 4500 lbs., 40 mph.
OS: Permitted off highways.
DOG: Permitted on 6 foot leash.

KANSAS

MSL: On turnpike, 80 mph. In interstate highway, 75 mph days, 60 mph nights.
OS: Permitted off highway.
DOG: Permitted if leashed.

KENTUCKY

MSL: 60 mph days, 50 mph nights
OS: Permitted off highway.
DOG: Permitted in state and county parks if leashed.

LOUISIANA

MSL: 35 mph.
OS: Permitted off highway.
DOG: Permitted in state parks if leashed.

MAINE

MSL: 45 mph.
OS: Permitted off highway.
DOG: Permitted if leashed.

MARYLAND

MSL: 50 mph.
OS: Not prohibited.
DOG: Permitted in state forests, but not state parks.

MASSACHUSETTS

MSL: Divided highways, 50 mph. Other highways, 40 mph.
OS: Determined by local regulations.
DOG: Permitted on 10 foot leash. Not allowed on beaches.

MICHIGAN

MSL : 50 mph.
 OS : No information available.
 DOG : Permitted if leashed.

MINNESOTA

MSL : 65 mph days, 55 nights.
 OS : Prohibited except where posted.
 DOG : Permitted on 6 foot leash.

MISSISSIPPI

MSL : 50 mph or as posted.
 OS : Permitted off highway.
 DOG : No information available.

MISSOURI

MSL : On Federal divided highways, 70 mph. Other highways 65 mph days, 60 mph nights. Cities, towns and villages 55 mph unless otherwise posted.
 OS : Permitted off highway.
 DOG : Regulations vary, inquire at each park.

MONTANA

MSL : 50 mph.
 OS : Permitted as posted.
 DOG : Permitted if leashed.

NEBRASKA

MSL : Less than 23 foot trailer, same as autos. 23 foot and over, 50 mph.
 OS : Permitted off highway.
 DOG : Permitted in state parks if leashed. Check at county parks.

NEVADA

MSL : "Reasonable and proper," or as posted.
 OS : Permitted off highway.
 DOG : Permitted if leashed.

NEW HAMPSHIRE

MSL : 45 mph.
 OS : Permitted off highway.
 DOG : Permitted in state parks.

NEW JERSEY

MSL : 50 mph.
 OS : Permitted.
 DOG : Permitted in state and county parks.

NEW MEXICO

MSL : 60-70 mph days, 50 mph nights.
 OS : Permitted off highway.
 DOG : Permitted if leashed.

NEW YORK

MSL : 55 mph.
 OS : Not permitted.
 DOG : Permitted if leashed and proof of rabies inoculation.

NORTH CAROLINA

MSL : 45 mph.
 OS : Permitted off highway.
 DOG : Permitted in state parks on 6 foot leash.

NORTH DAKOTA

MSL : 60 mph, 50 mph nights.
 OS : Permitted off highway.
 DOG : Permitted on leash.

OHIO

MSL : 70 mph days, 50 mph nights.
 OS : Not permitted.
 DOG : Not permitted.

OKLAHOMA

MSL : Passenger car/trailer 60 mph. Pickup/trailer 65 mph days, 55 mph nights. 1000 lb. load, 50 mph.
 OS : Permitted unless posted otherwise.
 DOG : Permitted if leashed.

OREGON

MSL : 55 mph. If not posted, "reasonable and prudent."
 OS : Permitted at roadside rest areas.
 DOG : Permitted if leashed.

PENNSYLVANIA

MSL : 50 mph.
 OS : Permitted off highway.
 DOG : Not allowed.

RHODE ISLAND

MSL : 35 mph.
 OS : Permitted off highway.
 DOG : Permitted.

SOUTH CAROLINA

MSL : 55 mph.
 OS : Permitted off highway, but not recommended.
 DOG : Check at each park.

SOUTH DAKOTA

MSL : 70 mph days, 60 mph nights.
 OS : Permitted off highway.
 DOG : Check at parks.

TENNESSEE

MSL : Interstate highways, 65 mph. Other highways 50 mph or as posted.
 OS : Permitted at roadside parks or rest areas.
 DOG : Permitted in state parks if leashed.

TEXAS

MSL : 60 mph days, 55 mph nights.
 OS : Permitted off highways.
 DOG : Permitted if leashed.

UTAH

MSL : As posted.
 OS : Permitted off highway.
 DOG : Permitted if leashed.

VERMONT

MSL : 50 mph or as posted.
 OS : Permitted off highway.
 DOG : Permitted in state parks on 7 foot leash if there is no beach.

VIRGINIA

MSL : Interstate or four lane divided highways, 50 mph. Other highways, 45 mph.
 OS : Permitted off highway.
 DOG : Permitted if leashed.

WASHINGTON

MSL : Days, 60 mph in 70 mph zone, 50 mph in 60 mph zone. Nights Use posted truck speeds
 OS : Permitted off open highways only, not at roadside rest areas.
 DOG : Permitted if leashed.

WEST VIRGINIA

MSL : 55 mph.
 OS : Permitted off highway.
 DOG : Permitted if leashed.

WISCONSIN

MSL : 65 mph days, 55 mph nights.
 OS : Not permitted.
 DOG : Permitted at state parks if leashed. Check at county parks.

WYOMING

MSL : Four lane divided highway, 75 mph. Other highways, 65 mph.
 OS : Not permitted.
 DOG : Permitted in state parks if leashed.



G 19 WINTER AIRSTREAMING

Travelling in an Airstream during the cold winter months can be one of the most exhilarating experiences in all trailering. When we speak of cold, we are talking about temperatures of **zero to -10 or -15 degrees**. Airstreams have been cold-soaked at **-20 degrees** with no adverse effects and with no real discomfort.

There are of course certain precautions which must be taken as there must be taken in your own home in low temperatures.

1. **You must have heat in the trailer at all times.**
2. **You must have a plentiful supply of propane gas.** It goes pretty fast in extremely cold temperatures.
3. If your stay is longer than overnight (without driving to recharge your battery) then you should endeavor to have 110 V electricity available. Your battery (fully charged) will not last more than about 18 hours in zero weather. Of course you can always run your car to recharge the battery and normally the battery will

attain sufficient power to run another 9 hours by running your engine for approximately 45 minutes to one hour at idle.

4. **Minimize use of electricity** if 110 volt power source is not available.
5. Your Airstream has forced air heating in the holding tank and trunk area. There is also heating around the water tank. At night or when travelling; open the wardrobe doors if there are water lines inside them; open the drawer fronts under the beds and pull the bed away from the wall slightly to allow the heat to circulate around the pipes.
6. **Do not pack things around the water pipes that prevent air circulation.**

By following the above suggestions, you may enjoy your Airstream year round, in cold and as well as in warm weather.

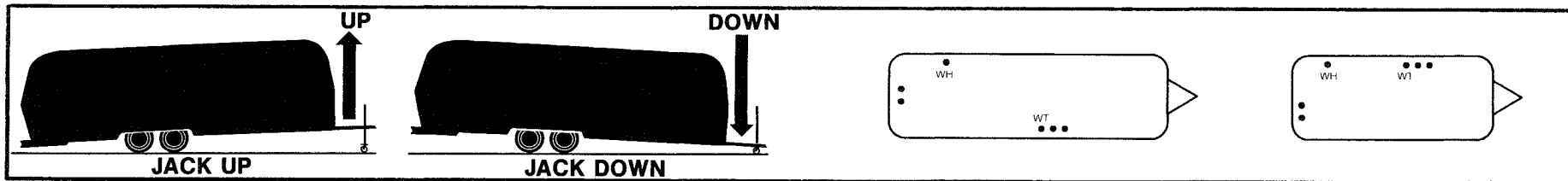

H 20 TRAILER STORAGE AND WINTERIZING

When storing your trailer for short or long periods during above freezing weather, use the same precautions as you would in your own home in regards to perishables, ventilation and rain protection. In addition, for prolonged storage periods, flush out all the drain lines and the holding tank. Also, drain the water system to prevent water from becoming stale. (Including the water heater and the water storage tank.) For draining water system, use applicable instructions in the next section on winterizing your Airstream. Twice a year or after long storage periods, we suggest you take your unit in for a check-up and cleaning of the gas operated appliances.

The main consideration in winterizing is to guard against freezing damage to the hot and cold water systems, the waste drain system (including the traps), the waste-holding tank, the water heater and the battery. To completely winterize your Airstream, follow this procedure:

1. Level the trailer from side to side and front to rear. Open all the faucets.
2. Turn the water pump switch to the OFF position.
3. Open all drain valves. There are five: two are located in the rear of the unit and three are under the galley sink. The water tank drain valve is under the floor. (see illustrations)
4. While the water is draining from the system, open and flush the toilet flushing valve. Depress hand spray thumb button and hold the spray head below rim of the toilet and drain the hand spray line. **There is danger of damage from freezing if water remains in these lines and valves.** Drain all water from telephone showerhead flexible hose.
5. **Lower the front of the trailer as far as the jack will allow until water ceases to drain, then crank the jack up as high as it will go and let any remaining water drain out the rear drain valves.** (see illustrations)
6. After the water has stopped running from the drain lines, if available apply air pressure to the drain lines with all drain valves and faucets still open. This will force any remaining water from the water heater and remove any water which may be trapped in low areas.
7. Pour a cup of antifreeze (Glycol) into the lavatory, sink, and tub drains to prevent freezing of water in traps.
8. Be sure to open the waste-holding tank drain valve and drain and flush the tank thoroughly. (This is very important as the **sewage in the tank, if frozen, could seriously damage the tank.**)
9. Remove the lower portion of the water purifier, if your trailer is so equipped, and drain the purifier.
10. Disconnect the inlet and outlet connections of the water pump and turn the pump by hand until all the water is expelled.
11. **It is very important for optimum life of your battery to check it periodically and to keep it fully charged.** This is especially true in winter months when the temperature may drop below freezing. Please refer to the electrical section for more information on battery maintenance.
12. **Remove any items (food, cosmetics, etc.) from trailer interior** that might be damaged by freezing-or might damage the trailer if containers break.

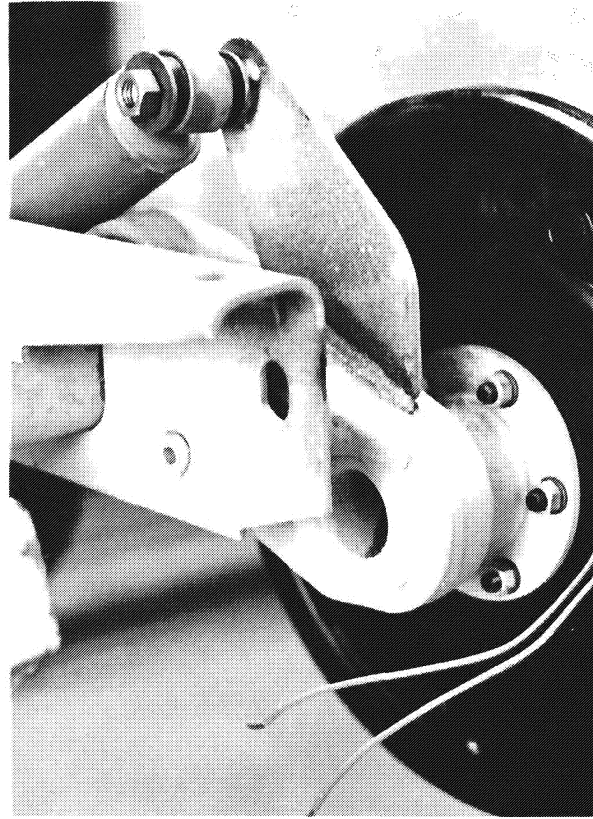
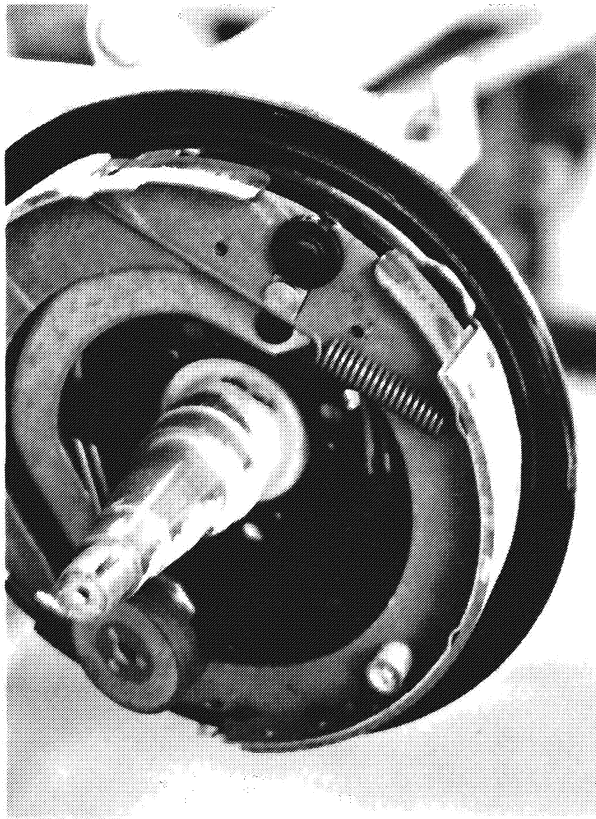

I 21-22 CHASSIS, RUNNING GEAR AND TIRES

The Dura-Torque axle is designed to last the life of your trailer without service, except for lubrication of the wheel bearings. **Under no circumstances should welding be done on or near the axle.**

The **Kelsey Hayes Brakes** are operated by 12 volt current from your car and **must be hooked up so that you have an integral system with your car brakes.** To prevent problems and insure satisfactory braking action, install a Kelsey Hayes Controller (or equivalent) and variable resistor in line with the controller in your car.

The break-away switch is a device which (in the event of an accidental separation of the tow vehicle and trailer) will set and lock

the trailer brakes for a sufficiently long time to bring the trailer to a stop. The switch is activated by the removal of the small plug in the front of the unit and the plug is removed by the wire attached to it and to the car.

Airstream recommends that your brake system be checked and adjusted by a Certified Service Center. However, in emergencies, to adjust brakes:

1. Remove the small rubber plug at the base of the backing plate on the brake drum.
2. Jack the wheel up so that you can spin it by hand. Tighten the brakes (using a brake adjusting tool or a screwdriver that

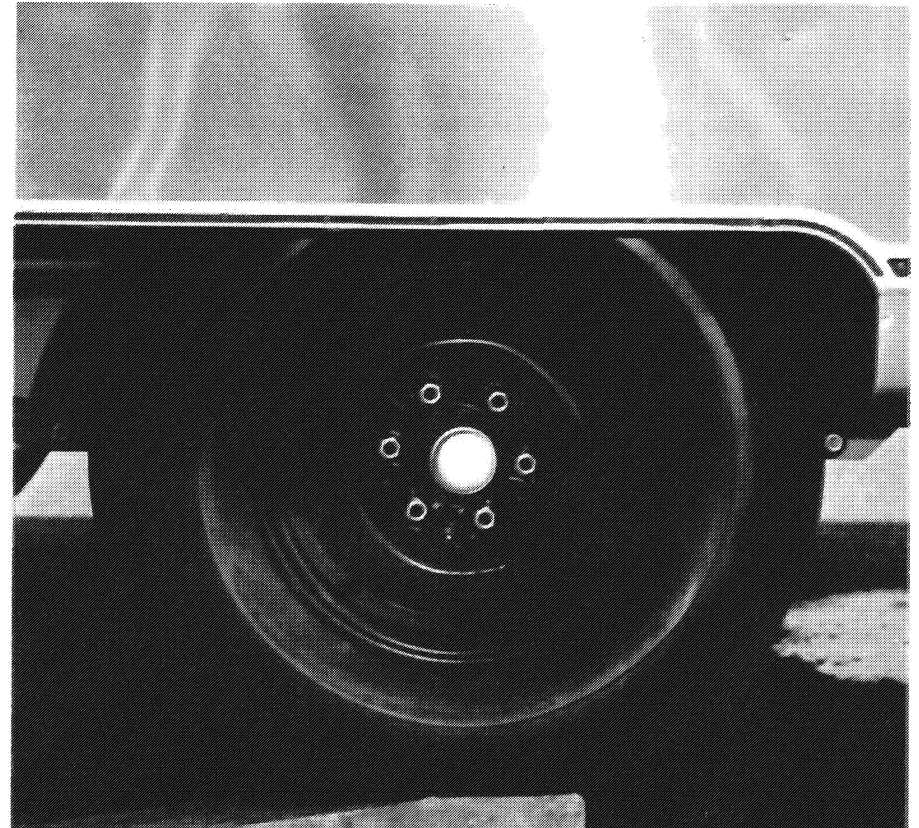

has been bent to a 90° angle) until the wheel is locked, then back off until you have a free spinning wheel (which will be approximately 15 notches).

3. Repeat this operation with all trailer wheels.

Your Airstream is equipped at the factory with **name brand travel trailer tires**. Airstream dealers cannot make adjustments to tires. This must be done by a dealer who handles that particular brand. If you ever have tire problems, check the local telephone directory for the nearest dealer.

To get the maximum performance from your tires:

1. Check the air pressure often, but only when the tires are cool and never bleed out air immediately after driving. Recommended tire Pressure for 7:00x15-6 ply is 45 psi, and for

7:00x15-8 ply is 60 psi.

2. Whenever possible, in warm climates, park out of the sun. In desert regions use tire covers to prevent ozone deterioration.

The independent suspension of the Dura-Torque Axle allows a four wheel unit to be safely driven on three wheels if a spare is not carried. A flat tire may be changed without the aid of a jack by driving the unit up a ramp as described in section "F" and pictured above. On all trailers a 3" aluminum pad is provided to indicate the proper jack placement position.

It is also important to periodically **check on the tightness of your lug nuts**. They should be tightened to a torque of 110 ft. lbs., and if you do not have your own torque wrench, this should be done at a service station.

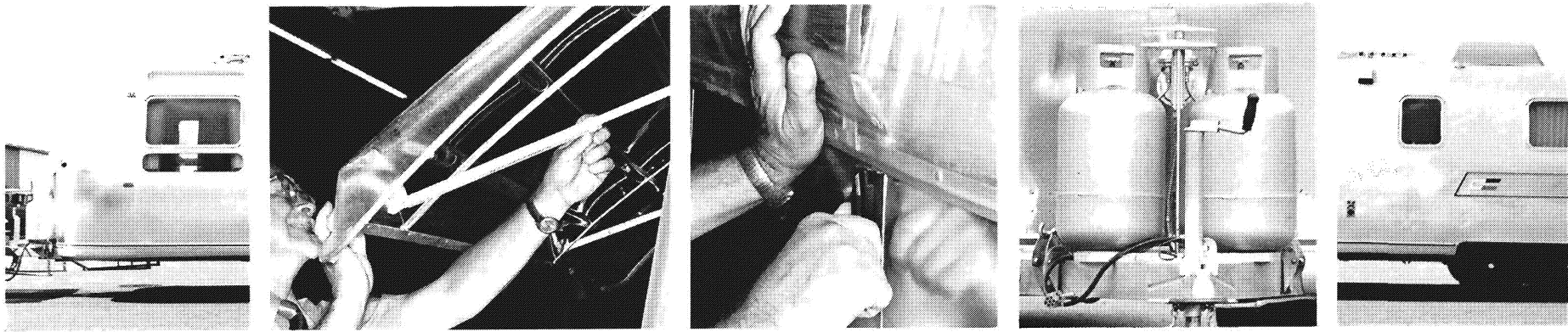

J 23-24 EXTERIOR SHELL

Your Airstream has been protected by an **acrylic lacquer finish** applied at the factory. This impervious film should afford years of satisfactory service. Washing the exterior of your Airstream is similar to washing an automobile. Both have high quality finishes and certain precautions must be taken to protect them. Oil, grease, dust, and dirt may be removed by washing with any mild non-abrasive soap or detergent. **Automatic dishwasher detergents and acid etch cleaners are too strong and should never be used.** Always clean your Airstream in the shade or on a cloudy day when the aluminum skin is cool. Cleaning should be followed by a thorough clean water rinse. Spots and streaks may be prevented by drying the unit with a chamois or a soft cloth.

After cleaning and drying, a good grade of non-abrasive automotive paste or liquid wax will increase the life of the finish, especially in coastal areas where the finish is exposed to salt air or in polluted industrial areas. It will also protect the shell from minor scratches and make subsequent cleaning easier. Wax should normally be applied every three to six months.

It is important to remove sap, seeds, gum, resin, asphalt, etc., as soon as possible after they appear by washing and rewaxing. Sunlight and time will bake-harden these materials making them al-

most impossible to remove without heavy buffing. If asphalt remains on the trailer after washing, use a small amount of kerosene on a rag and wipe the spots individually, being careful not to scratch the aluminum.

For small areas of damage to the acrylic protective coating, or where oxidation is beginning to occur, remove all traces of the acrylic coating with a good grade of lacquer solvent and then thoroughly clean the aluminum with an aluminum cleaner. Then respray the area with clear acrylic lacquer. **All items needed for these minor repairs to the exterior shell are available at Wally Byam Stores.** For extensive refinishing we recommend that you contact an Airstream Service Center or the factory for instructions or to arrange for factory service.

The front window guard is made of long lasting Butyrate, a material that, like the exterior shell, must be washed with care. Use soap and water only, as any abrasive cleaning agents will damage it.

To keep your trailer looking new, paint the "A Frame," L.P.G. tanks, and rear frame periodically, by brushing on aluminum lacquer or, if possible, by paint-spraying. If your trailer has an air conditioner, paint its exterior shroud.

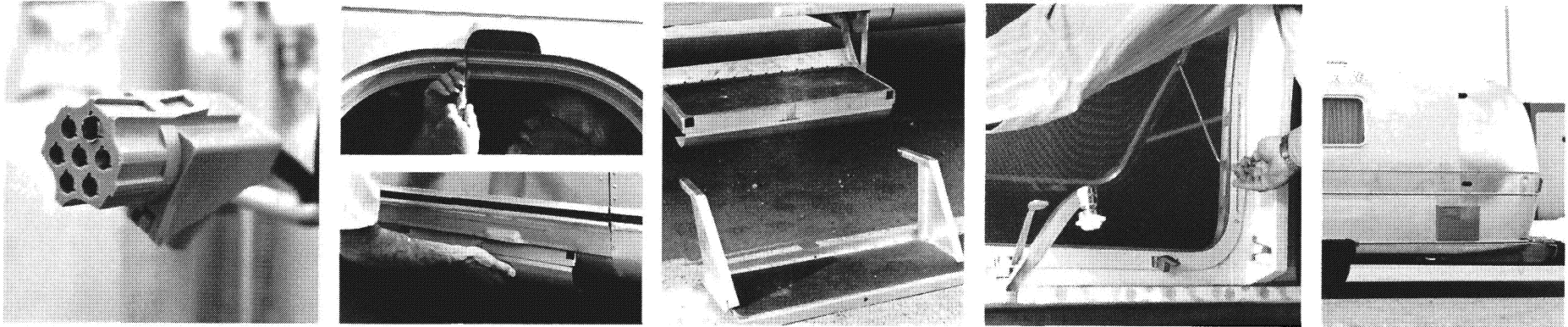

Check the 7-way electrical connector for dirt and corrosion and keep the contacts clean with “Spra-kleen”.

It is very important that the main door to your trailer be completely closed and locked during towing. If it is not locked, the constant vibration of travel can cause it to fly open and possibly cause damage. The latch acts as a deadbolt. Do not slam it when in the locked position. Should you find it difficult to unlock, push in, to release pressure on the door latch. The latch handle will be firm only when closed. When open, a self actuating latch will hold the door against the side of the trailer.

The screen door latches with a nylon catch to the main door. To use independently, slide the catch, close the center panel of the screen door, and attach the main door to the exterior with the self actuating latch.

The main door light (standard on Internationals, and optional on Land Yachts) is operated by a switch inside, forward of the door. Replace the bulbs by removing the two screws and the lens.

The Fold-Away Step is lowered into the open position by pulling out the handle below the main door, allowing the step to drop into a locked position. If it does not lock, pull out on the step itself until it does. To return the step, grasp the lower front edge, then push it upwards into the opening sufficiently to engage the

lock. Watch your fingers, keep them off the top of the step.

The Extension Step fits into the holes in front of the Fold-Away Step. For travel, it should be stored in the bracket provided under the trailer, forward of the main step. **Never travel with the Extension Step inserted or the Fold-Away Step lowered.**

The windows in your trailer are of tempered safety plate glass. To open: release the two lever locks at the bottom, lift up on the two side operator handles until the window is in the desired position, and place the operators into one of the three positioning slots on the side of the frames. To lock the windows, reverse this procedure.

These windows are cleaned in the same manner that ordinary windows are. Clean the seals with a damp cloth or mild detergent every three to six months taking care not to use strong solvents as they will damage the seals. A coat of natural silicone lubricant applied after the seal has dried will keep it flexible. Spread the lubricant evenly with a brush or finger, working it into the surface. This is a good practice for all rubber seals in your Airstream. **For replacement of a damaged window contact an Airstream Service Center or the factory.**

Screens are made of plastic for hard wear and easy maintenance. Clean with a damp cloth. **Note: they will melt at the point of contact if touched by a cigarette.**

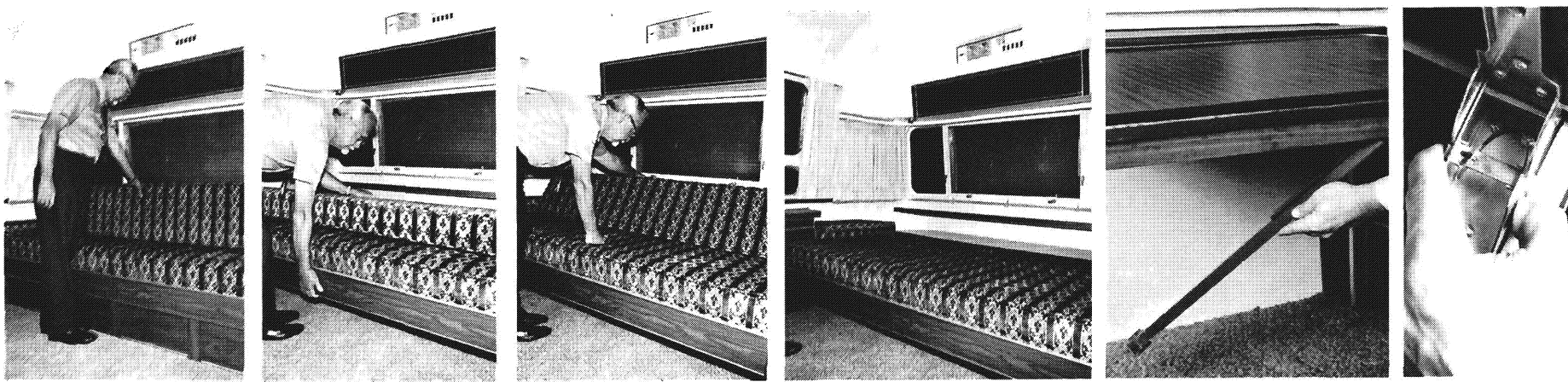

K 25-27 INTERIOR

The Airstream interior has been designed for comfort, convenience, durability and appearance. An understanding of the operational procedures and maintenance techniques of the interior appointments will add to your pleasure as well as the long life of your trailer.

To convert the Lounge into a bed, pull the back cushion down toward you onto the seat. Grasp the front rail of the seat in the center, lift it slightly and pull it out until it stops. Lay the back cushion down to finish the bed. To return, reverse this process.

Make beds in the usual way, using fitted sheets 3/4 bed size. The space behind the rear cushion is ideal for storing bedding for both front travel lounges and side pull-out beds. An easy method of storing bedding is to remove and store pillows and then fold back the ends of the bedding neatly to expose about 2" of the mattress; then, starting from the edge nearest to you, roll up the bedding as tightly as possible towards the back wall. Raise the rear cushion to its normal position.

The fixed twin beds pull out enough to make the tucking of bedding along the wall quite easy. Note: please do not launder mattress ticking, it has to be dry cleaned to prevent shrinkage.

To open the table, slide it aside, enough to clear the front lounge, and lift to the horizontal position, hold it there, and pivot the folding leg into the vertical position. The leg will automatically lock in the open position.

To stow, unlock the vertical leg by pressing in the locking tab, and reverse the process.

The Credenza Table should be stored while towing. Be certain to secure the lock underneath the extension slide when stored, and to fasten the small catch on the table edge.

To extend the Credenza Table, unlock the latch underneath (near the leg). Lift the table slightly off the floor, and pull out the table frame with the leg as far as it will go. Release the small catch on the shelf side of the table edge, rotate the extension leaf over and lay it on the frame. **By raising the leg off the floor, the entire table can be slid fore and aft for seating comfort.**

All the drawers and shelves are removable allowing you storage flexibility and ease of packing and unpacking.

Wardrobe catches are self locking and they may be opened by sliding the bolt away from the door opening.

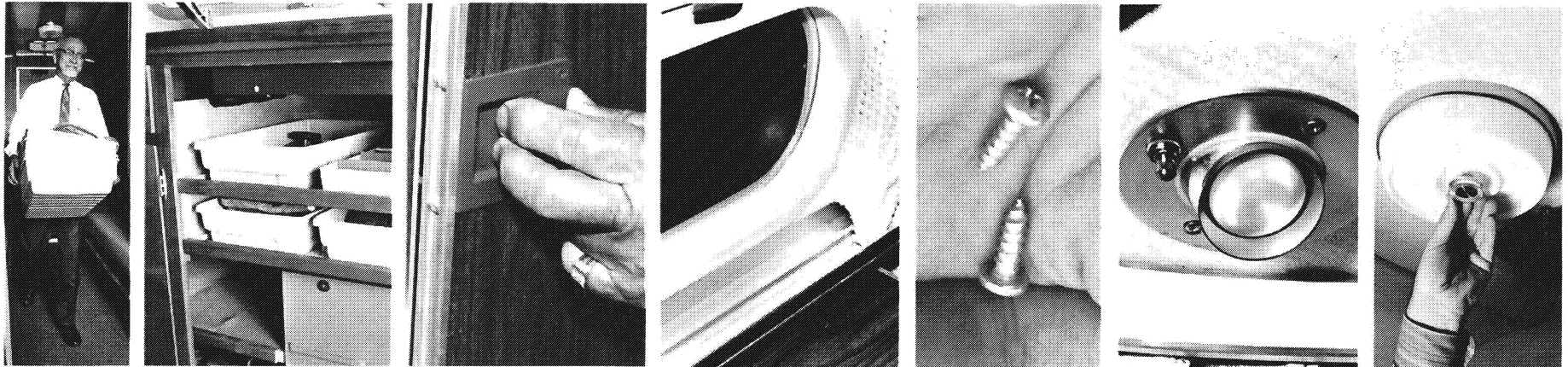

The vertical and horizontal tambour doors slide in tracks that should be kept clean and waxed for smooth operation.

Drapes are on tracks at both top and bottom, to keep them close to window and wall, and to prevent movement during travel. **They should be dry cleaned only.**

Carpets are hard wearing polyester, 2 ply, Kodel II yarn. Vacuum for normal cleaning and use a small carpet rake to help retain the fluff of the shag. Clean with a good shampoo periodically.

Floor Tiles should be cleaned with warm water and detergent and coated with liquid or paste floor wax.

The walls are finished in vinyl for easy maintenance. Clean with suds from a mild detergent, adding a small amount of bleach to the water. A damp bristle brush may be used for scrubbing. Rinse with clear water and wipe dry. **Kerosene, naphtha, carbon tetrachloride, lighterfluid, Energine and similar solvent cleaners will damage the vinyl. Abrasives may wear off the pattern and destroy the luster.**

When attaching wall hung improvements, like hooks for clothing, bookshelves, and extra towel racks, secure with half-inch No. 8 sheet metal screws with flat binder heads, make holes in the alumi-

num inner walls with a small hand drill (No. 32 drill bit).

Work surfaces, partition walls, and furniture panels are of melamine laminate, and resistant to solvents, stain, acid and scratching. Waxing will help preserve their luster. Never use abraive cleaners. **Do not take hot pots off the stove and place them on the work surface.**

Area lights have switches on the rim. Ceiling light fixtures are operated by 4-position switches in the fixtures. Starting from the OFF position turning clockwise, the switch turns on first one, then three, then four bulbs, then off. To replace a bulb, unscrew the switch knob and remove the retainer nut.

Bed-lights are operated by a switch on the side and can be tilted for better light distribution. To replace bulbs, remove the screw near the switch and pull the cover slightly forward and the cover will come off, exposing light bulbs. To replace cover, align the hole in the cover with the pin in the side, and replace the screw.

Vents keep the rain out while allowing air circulation. To open, rotate the hand cranks. For maximum ventilation, open both cranks. For less, open one end only. Screens should be removed for regular cleaning: remove the hand cranks and screws and pull the screen downward. **Optional fans are available to increase circulation.**

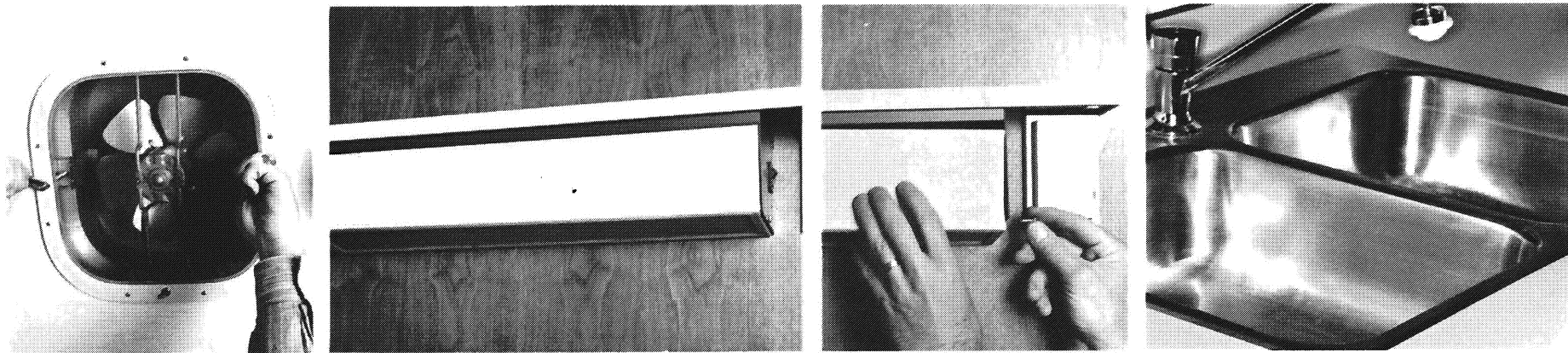

Furnace lighting instructions are found on the plate inside the door. Technical details may be found in section “M”.

Water Heater lighting instructions are inside the door, (which is to be opened only for lighting.) For full details, see section “M”.

Range and Oven cleaning instructions and technical data may be found in Section “M.”

The range exhaust provides venting of cooking heat and smoke from the trailer. To operate, flip the cover on the undersurface of the hood. The fan (optional) switch is located under the tambour door next to the filter. Clean the filter regularly with warm water and detergent. To remove the filter, open the roof locker and slide it out. **Keep the vent housing clean from grease and dirt by frequent washing.**

Refrigerator lighting instructions are on the kickplate. Technical and defrosting information may be found in section “M”.

Ordinary soaps or detergents are best for routine cleaning of the stainless steel sinks. Rinse thoroughly with warm water and wipe dry with a cloth to avoid streaks and spots.

Stainless steel sinks cannot be harmed by boiling water. However, **salt, mustard, mayonnaise and ketchup will cause pitting.** Stubborn

stains will yield to paste made of water and a slightly abrasive cleaner. Be sure to work in the direction of the polish-lines on the steel, to keep the original finish. Fingerprints are sometimes a problem. They can be minimized by applying a cleaner that leaves a film of thin wax: simply wipe it on and remove the excess with a dry cloth. After this, fingerprints can be wiped off with a soft dry cloth, or one moistened with a little wax cleaner. The surface should always be washed before wax is applied. Regular cleaning will prevent build-up of scale and film.

The Lavatory bowl, counter top and tub in your Airstream bathroom are made of a special long-wearing, light weight, high strength material. When cleaning, use soap or detergent only—**never use scouring powder.**

The telephone shower head is designed to give maximum flexibility in usage and provide for water saving techniques when using your trailer on self-containment. For operational procedures refer to Section ‘N’.

The medicine chest is behind the mirror in the bathroom. The 120 volt and optional 12 volt outlets are located below the medicine compartment on the roadside of the unit.

The toilet exhaust fan is in the bathroom wardrobe wall left of the toilet. Complete toilet instructions are in section “N”.

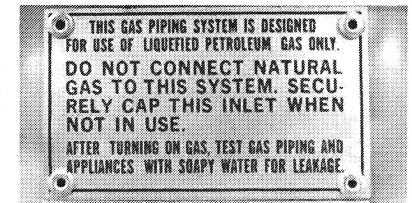
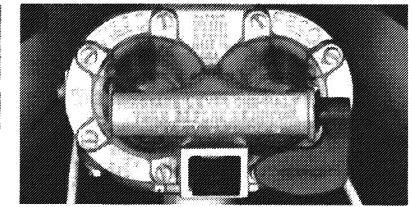
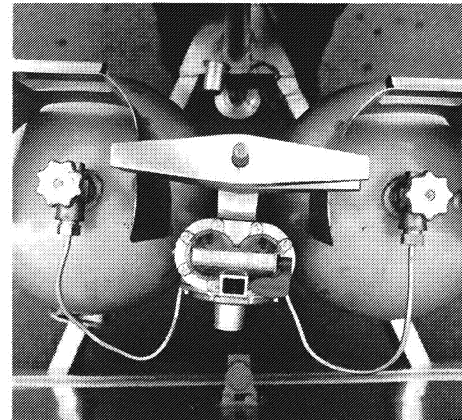
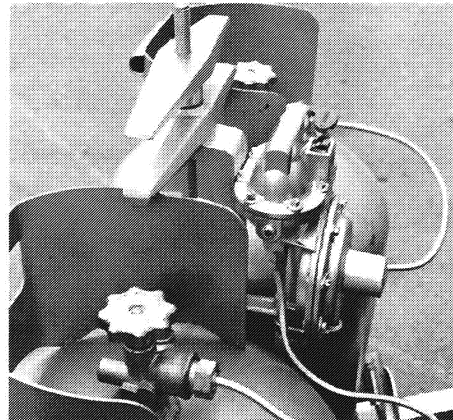
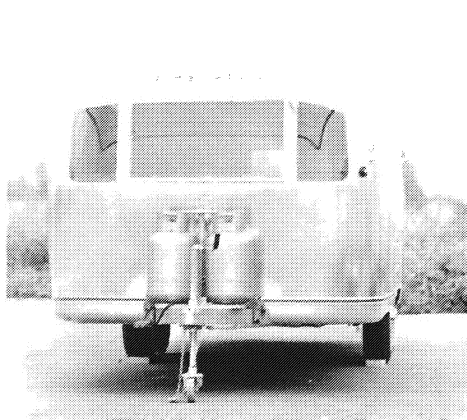

L 28

L.P.G. SYSTEM

Your Airstream is equipped with two tanks for LPG (Liquid Petroleum Gas). LPG burns with a clean blue flame and produces **more heat than natural gas**. There are two basic types of LPG in common usage: **Butane** and **Propane**. Butane is widely used where temperatures are normally above freezing the year around and Propane is used where subfreezing temperatures are common, since Butane freezes at 32° F as compared to -40° F for Propane. **All of the orifices in your Airstream LPG appliances are of the universal type which will burn either fuel.**

How long a full tank of gas will last is of course dependent on usage. In cold weather when you are using the furnace, large amounts of hot water, and are doing extensive cooking, you will naturally use more than you will in warm weather when you may do limited cooking. On the average, with normal cooking and other appliance use, you can probably count on three weeks service from each 28-lb. tank.

International models are equipped with an **Automatic Gas Regulator**. Both tanks are connected to this regulator and are turned on. Gas is drawn from only one tank at a time and when the tank being used is depleted the regulator automatically switches to the full tank. An indicator on the regulator points toward the tank being used to give you a visual reminder when one tank is

empty. The empty tank can be removed for refilling without disturbing the tank being used. Simply close the tank valve, disconnect it, have it filled and reconnect.

If you have a manual regulator, open only one valve or both tanks will empty at the same time.

To remove the gas tanks, disconnect the tubing nut with a wrench and loosen the bar handle which holds the tanks in place. **The tubing nut has a left hand thread so be sure to always turn it clockwise to loosen and counter-clockwise to tighten. When replacing a tank, connect and tighten the tubing nut before clamping it in place.**

If you have allowed both tanks to run out, air may have gotten into the lines. In this event, the **air must be forced out through the lines by gas pressure before you will be able to light your pilots**. Hold a match to the pilot of the appliance closest to the tanks until it lights. Then move to the next closest, etc. For complete appliance operation instructions, refer to section "M", and for their B.T.U. ratings, refer to section "R".

Note: In some states it is illegal to leave the gas tanks turned on while towing a trailer.



M 29-31 APPLIANCES — REFRIGERATOR

Your Airstream is equipped with an A.G.A. approved Dometic gas-electric refrigerator. These are the finest refrigerators available for travel trailer use and will give you many years of faithful service. **Whenever you park your trailer, care should be taken that it is level for best operation of this refrigerator. When parking try to avoid having a strong wind blowing directly against the vent outlet for most efficient operation.**

For gas operation, the tap must always be fully opened whenever the refrigerator is in use. A partially opened tap effects no savings and may interfere with the operation of the unit.

To light, open the refrigerator door. The controls are located inside the food compartment near the bottom of the unit.

1. **Before the refrigerator is started on gas, check that the electric**

switch lever (F) which is accessible through the outside access panel is in the off position. Turn the gas valve handle (A) to the open position and turn the thermostat knob GT to setting No. 4.

2. Pull knob (C) of the automatic pilot and after about 15 seconds turn the lighter rod (D) counterclockwise with a rapid movement. This will create a spark which lights the burner.
3. After the burner is lit, keep the button (C) pulled outward for an additional 15 seconds.
4. Release the button (C) and check that the burner is operating. The burner can be observed by looking into viewer (G). If the burner is not operating, repeat the lighting procedure.

Incorporated in the burner bracket is an automatic flame failure device which allows gas to pass only when the burner is lighted,

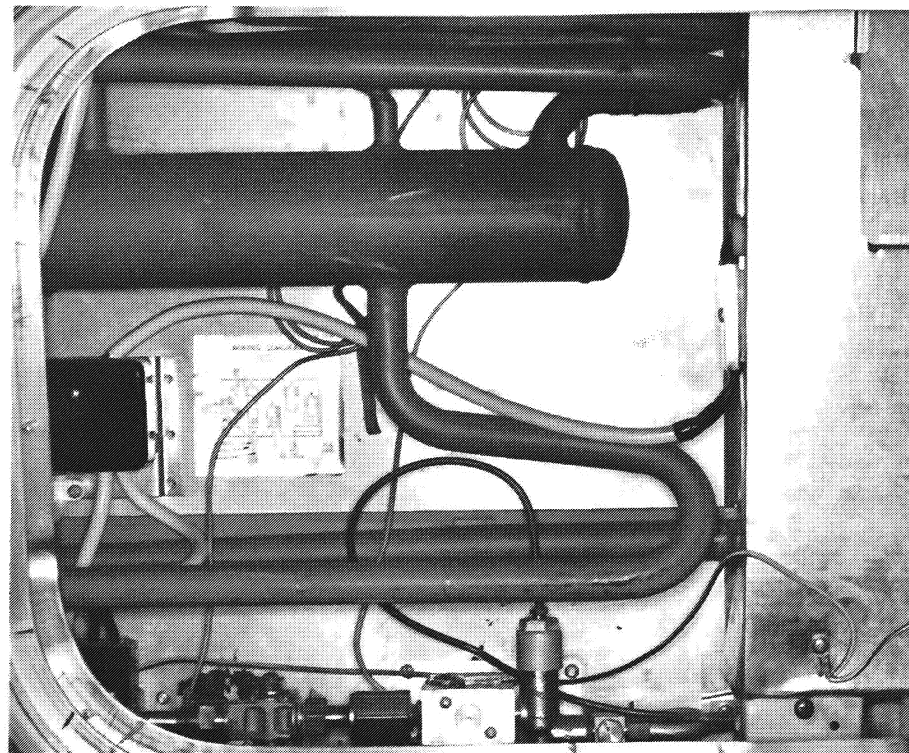
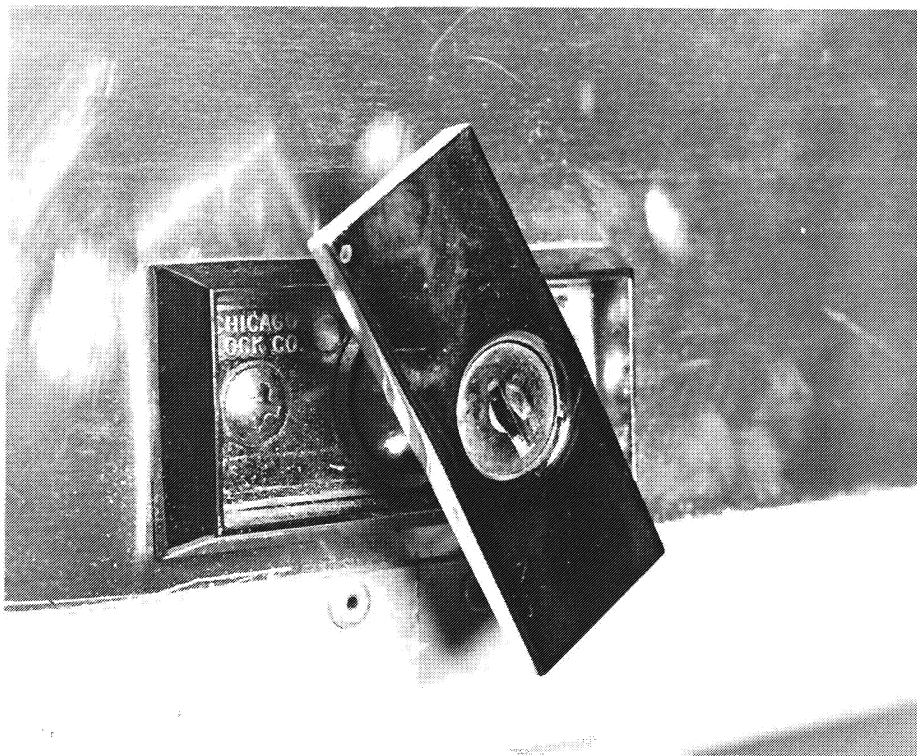

keeping the thermocouple hot. Should the flame be blown out, the thermocouple will cool and the device will cut off the flow of gas to the burner.

For electric operation, follow these instructions:

1. To start the refrigerator, turn the gas valve (A) to the shut-off position.
2. Check to be sure the electric cord is plugged into 110-volt outlet (at rear bottom of refrigerator). Turn the switch lever (F) which is accessible through the outside access panel to the ON position.
3. Turn the electric thermostat knob (ET) to setting No. 4.

The refrigerator has automatic thermostatic control of the temperature in the food storage space. The gas thermostat (GT) controls the temperature during gas operation, while the electric thermostat (ET) controls the temperature during electric operation. **Be sure**

to make the temperature setting on the correct thermostat.

As soon as the required cold temperature inside the cabinet is reached, the thermostat cuts the burner main flame to the by-pass flame sufficient to keep the safety valve open during gas operation. During electric operation the thermostat cycles the flow of the electrical current to maintain the set temperature.

Your Dometic incorporates a unique, fully automatic defrosting device for the general food storage compartment, which eliminates the necessity for manual defrosting at frequent intervals normally associated with most conventional refrigerators in the medium size range. Furthermore, the time interval of each defrosting cycle, and the frequency, have been so arranged that during defrosting there is no noticeable effect upon the temperature of the foods stored in the refrigerator, and the frozen food storage conditions can be maintained at all times in the frozen storage compartment.

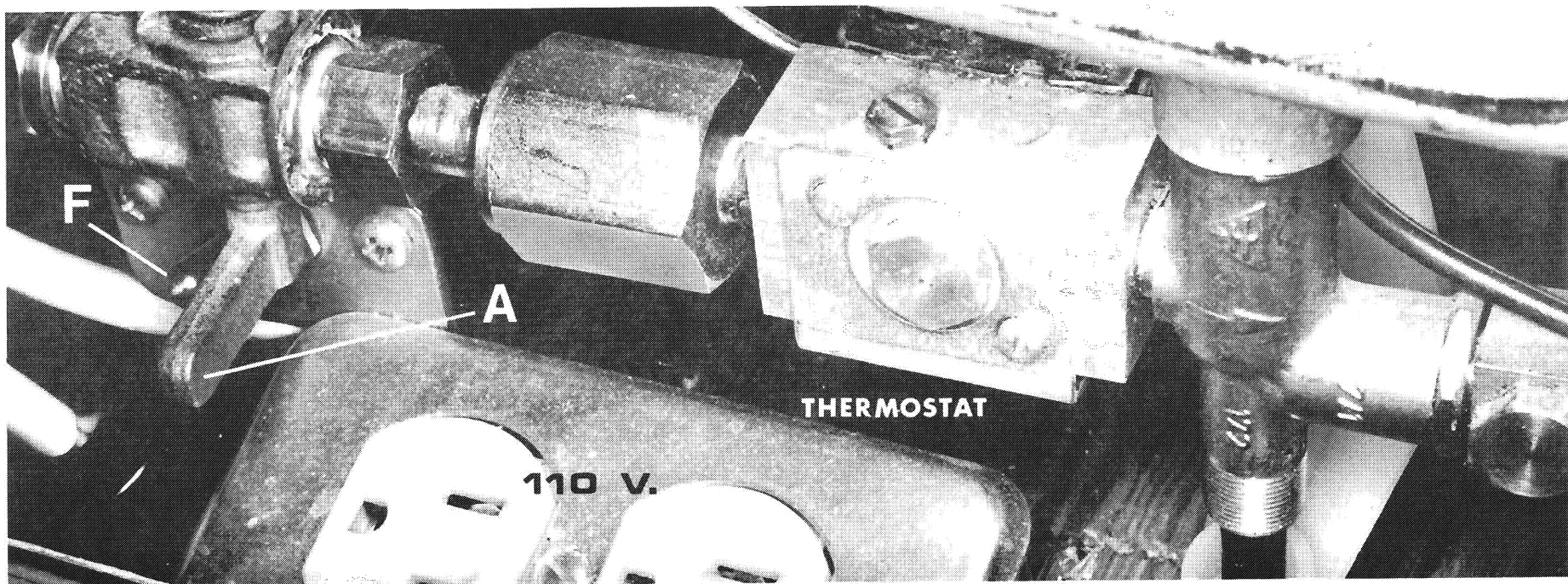

When cleaning, remove all food and clean the interior and all other plastic parts with warm water adding detergents. **Never use abrasive or caustic cleaning powders, polishes, cleaning paste or any gasoline, turpentine and the like.**

Use a damp cloth for cleaning and finish with a soft dry cloth.

When the refrigerator is to be out of operation for some time, always leave the door slightly open or place a pie tin with some barbeque charcoal on the shelf.

The small door on the side of the trailer behind the refrigerator is to provide access to clean and service the burner, to clean the burner flue stack, and to perform other maintenance and service. The door is opened by unlocking and turning the handle approximately 1/4 turn counterclockwise.

The following are some trouble shooting tips for emergency use only. They relate to gas operation and should normally be done

by the dealer.

Trouble: Flame goes out.

Causes and remedies-the thermostat is out of adjustment. To adjust it, turn the dial to "zero". If the flame does not go down to the "low" by-pass setting, follow this procedure:

1. Unscrew the large cap screw at the rear of the thermostat and remove the valve. Clean the seat and valve, and replace.
2. If procedure (1) does not correct the problem, adjust the set screw out (in counterclockwise direction) until the flame goes down to the "low" position.

If the flame keeps going out when the dial is turned to (0), remove and clean the by-pass screw which is located as shown in the illustration.

Trouble: Burner does not light.

Causes and remedies-Remove and clean the burner barrel, and or check the gas supply.

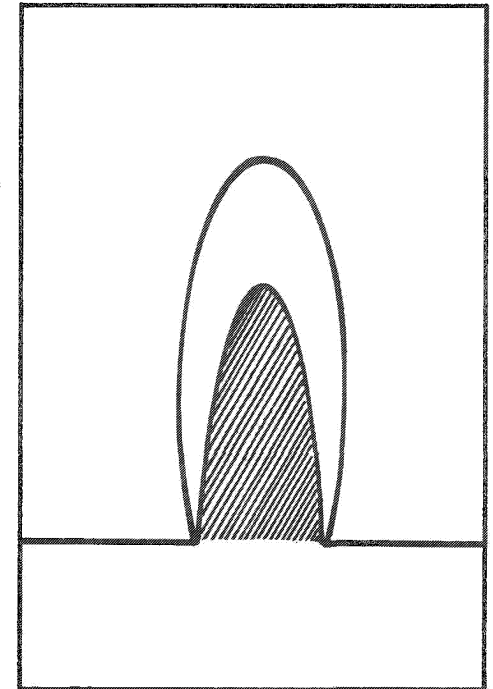

M 32-34 APPLIANCES — RANGE AND OVEN

Your Airstream is equipped with a Magic Chef gas range and Oven. The following are some hints on how to keep them operating at their best.

1. **Your range** is equipped with coaxial orifices for use with LPG. The flame will be approximately 1/2 inch long. **Do not attempt to adjust gas to burner. The orifices have no adjustment.**
2. Air shutters on top burners are to be adjusted so that each cone of the flame is separate and distinct and appears as illustrated in the figure on this page. Air shutters set too far open will cause the flame to lift away from the burner head and it will be difficult to light. If the air shutters are closed too much, the flame will look hazy and the distinct cones will be missing.
3. On International and Land Yacht models, adjust the top pilot

so that the tip of the flame is just over the edge of the inner cone. The burners should light within 4 seconds. If lighting is difficult, refer back to the previous step.

4. **Never allow the top cover to be closed while the range is in operation, as this will extinguish the flame and permit gas to escape into the trailer.**

Trouble shooting.

Trouble: Flame lifts off ports. Cause: Too much air. Remedy: Decrease air.

Trouble: Soot formations. Cause: Not enough air. Remedy: Increase air.

Trouble: Flame flashes back into air mixture chamber. Cause: Too much air in proportion to gas. Remedy: Slightly decrease air.

Trouble: Orange flame. Cause: Small filings in new burners or

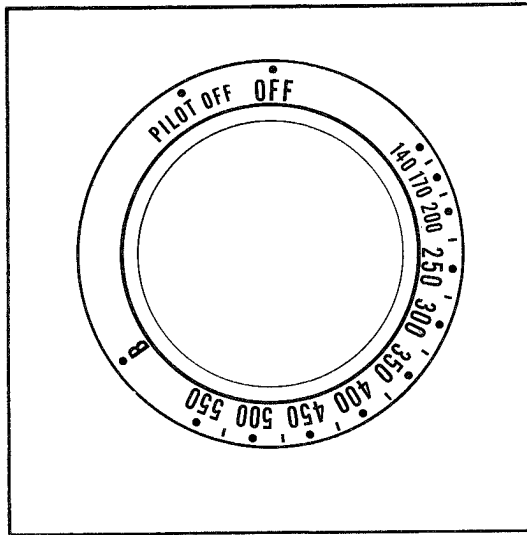

OVEN CONTROLS
LAND YACHTS
18 FT.- 25 FT.

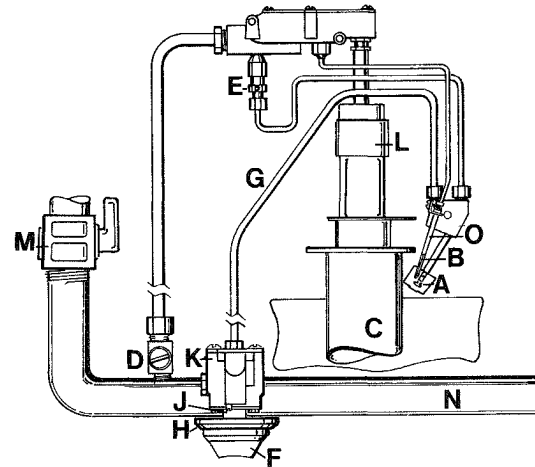

dust in air. Remedy: Clean burners.

Trouble: Burner fails to light. Cause: Usually too much air. Remedy: Decrease air.

Note: To adjust air gas mixture, rotate the sleeve behind the burner control knob. Decrease air by closing the opening, and increase air by opening it.

Important: **Your oven** is equipped with a safety ignition that requires a minimum of 30 seconds to operate after turning the oven control knob (F) on. The oven pilot may be slow in lighting due to air in the gas lines.

Oven Section 18 ft. - 25 ft. Land Yacht.

Important: **The automatic oven burner pilot** consists of a constant pilot and a heater pilot. The small constant pilot (A), which should be burning at all times when parked, ignites the heater pilot (B) next to the oven burner (C).

1. **To adjust the constant pilot (A):** Open shut-off valve (D), open pilot valve (E), reduce flame on constant pilot (A) until yellow tip disappears.
2. **To adjust the heater pilot (B):** Turn control knob (F) to 300

degree temperature setting. This will let gas flow through the heater pilot tube (G) to the heater pilot (B) where the gas is ignited by the constant pilot (A). Remove control knob (F) and bezel (H) and open heater pilot gas supply by turning green heater pilot adjusting screw (J) on front of control valve (K) until flame on heater pilot (B) yellows. Now close adjusting screw (J) until yellow tip disappears. See that flame envelops temperature sensing element (O). Replace bezel and control knob.

3. **To adjust main burner:** When adjusted to the proper rate it will have a flame approximately 3/8" long. The air shutter (L) on the main burners should be adjusted so the cone of each flame is separate and distinct as illustrated.

The **thermostat** on your oven does not have a by-pass setting. It will cycle off and on at all temperature settings except broil. No by-pass adjustment is necessary.

Note: On 23-ft. through 27-ft. Land Yacht models, the range gas line shut-off valve (M) located under the top of the range at the left end of the manifold pipe (N) must be turned off when towing the trailer, when changing the gas tanks, or if the gas supply is

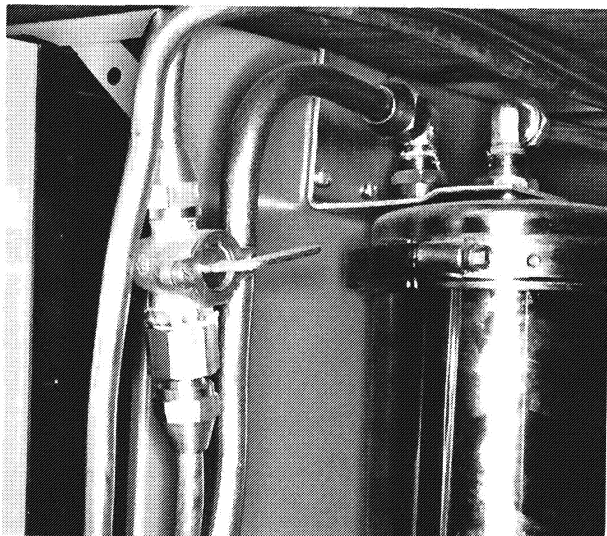

OVEN CONTROLS
INTERNATIONAL
27 FT.-31 FT.

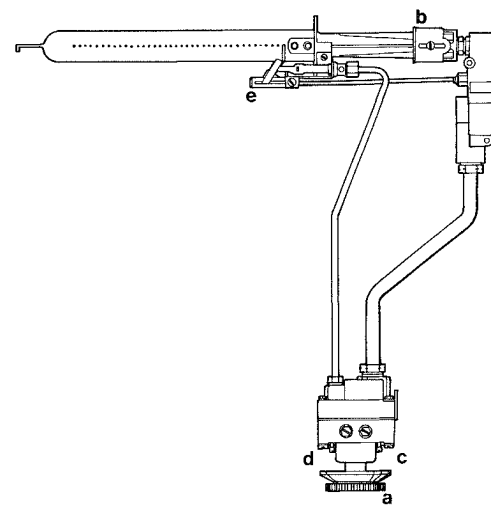

turned off for any reason. Be sure oven pilot light has been relighted as soon as range shut-off valve is turned on. The shut-off for the top burners is located under the range top and also should be turned off while traveling.

Oven section: International Models:

The Thermostat Control Knob (A) is combined with the constant pilot shut-off. For normal use: turn only between 'OFF' and 'BROIL'. When traveling, turn to 'PILOT OFF'. Relight only when you want to use the oven, by turning from 'PILOT OFF' to 'OFF' and lighting with a match.

The air shutter (B) on the main burner is to be adjusted so that each cone of flame is separate and distinct, as illustrated.

Constant Pilot Adjustment.

1. Remove Control Knob and Bezel (A).
2. Using a screwdriver, turn slotted red-colored Constant Pilot Selector (c) to LP position. When the slot is in the vertical position, the Selector Cartridge is in the 'OFF' position.

Heater Pilot Adjustment.

1. Replace Control Knob and turn to the 300 degree setting on

the Control Knob Dial. This opens the thermostatic valve in the thermostat and allows gas to flow through the Heater Pilot Tube to the Heater Pilot.

2. Remove the Control Knob.
3. Using a screwdriver, turn the slotted green-colored Heater Pilot Adjusting Cartridge (D) in either direction until the pilot flame just envelops the Temperature Responsive Element (E).
4. Replace Bezel and Control Knob.
5. Make any air shutter adjustments for oven burner flames.

Cleaning instructions after range and oven are in use.

1. The main top has been hinged from the back so that it can be raised for cleaning around the top burners.
2. When cleaning the top burner heads, care should be taken that all ports are opened up with a toothpick afterwards.
3. Spill-over or spotting in the oven or broiler are more easily cleaned when removed promptly after they occur. **Never wash porcelain when warm. Never use cleaning powder containing grit or acid. When oven bottom is replaced after cleaning and servicing, be sure that it is locked in place. The front return flange on the oven bottom must hook under the side support angles to prevent warping.**

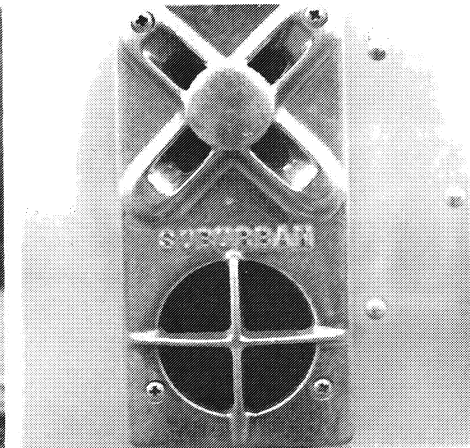
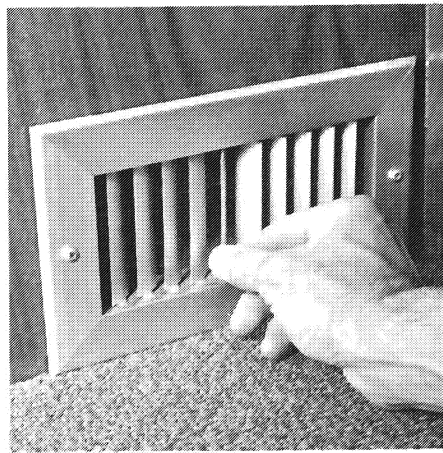
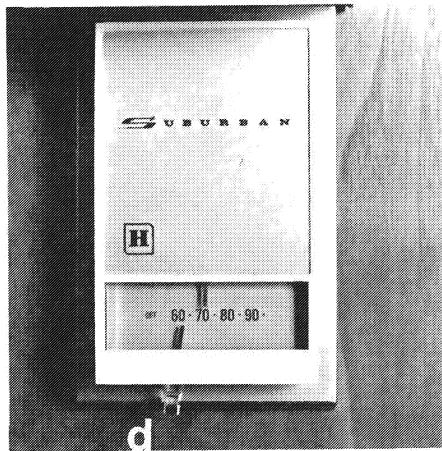
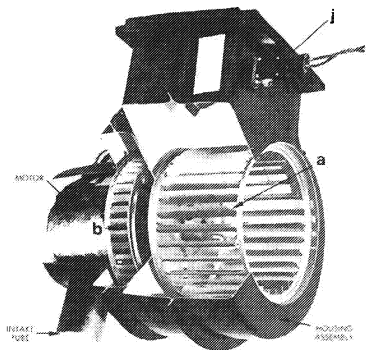

M 35-37 APPLIANCES — HEATER AND WATER HEATER

The Airstream furnace is an American Gas Association approved Suburban unit designed specifically for travel trailers. It has a sealed combustion system with a dual blower for maximum air circulation. One blower circulates room air while the other draws in air for combustion. The adjustable louvered heat registers control warm air flow while cold air returns through the galley cabinet toe kick opening.

The heat duct system also circulates warm air around the holding tank, water tank, and one-stop-service center, a vital feature when operating in below freezing weather.

Trouble-free operation of your Suburban heater will depend on your adherence to recommended operating procedures and precautions. Corrections of possible malfunctions presented here will be helpful in an emergency situation, but **servicing should be done by your dealer**. One note of caution regarding flue gases. They are vented from the furnace to the outside of your trailer through a vent in the outside wall. **Do not, in any way, obstruct this vent by placing clothing or other flammable material on the vent assembly. Check it often to make sure it never becomes clogged.**

The Suburban heater is thermostatically controlled. When the ther-

mostat calls for heat, the blower starts and only after it has reached nearly full speed will the burner light. After the temperature set on the thermostat is reached the burner will shut off, but the blower will continue to run for a short time removing most of the remaining heat from the heater, as well as forcing the combustion gases from the heat exchanger. To turn the heater off, turn the thermostat to its OFF setting and turn the manual gas valve to its OFF position (perpendicular to the gas line). Operating instructions are printed inside the furnace door.

The furnace may be lighted with the electromagnetic lighter or a match. Set the thermostat (D) to the OFF position, unlatch the furnace door, and open it. Turn on the manual gas valve and depress the reset button (E) then hold. Light the pilot by pressing quickly on the ignition button (F). After the pilot is lit, keep the reset button depressed for thirty seconds. Release the reset button and the pilot should remain lit. If the pilot goes out, repeat the above steps keeping the reset button depressed for a longer period of time. The pilot may not light immediately due to the presence of air in the gas line. It may be necessary to hold the reset button in for a minute or more before the pilot ignites. Once lit, close the front access door and set the thermostat. If the furnace has

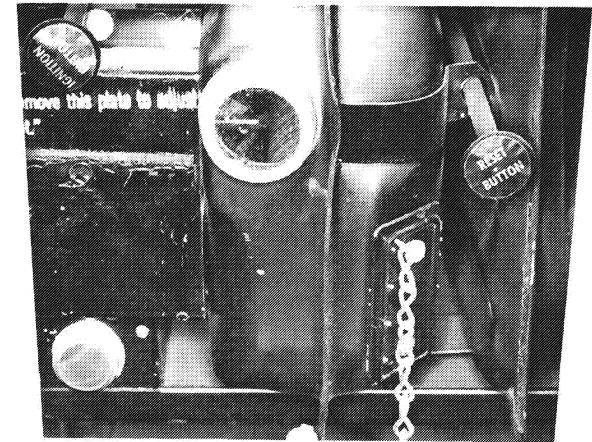
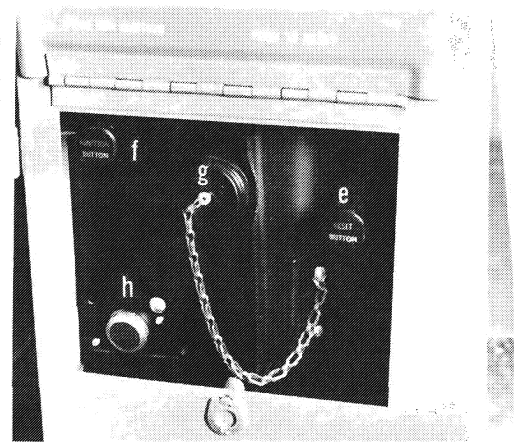
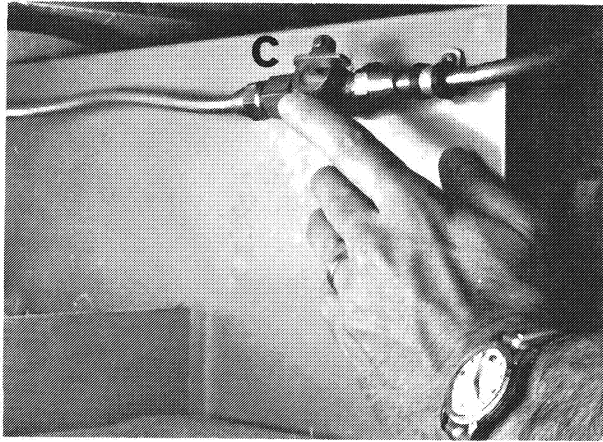

just gone out, turn the manual gas valve (C) off and **wait five minutes before attempting to relight the pilot.**

Differences in pressure between the room air and the outside air may cause a strong draft to come through the heater once the lighter opening cover is removed. Opening a window or the door on the same wall as the heater will prevent this from happening. Replace the lighter opening cover as soon as the pilot is lit and close any door or window you may have opened. Differences in inside and outside temperature will have no effect on heater operation once the lighter opening cover has been replaced.

Adjustment of Main Burner (Primary Air): Set the heater into operation by advancing the thermostat and allow to run until it reaches near-maximum operating temperature. Observe the main burners through the lighter opening cover. The flame should be without a trace of yellow and be “sitting” on the burner. As the heater was tested at the factory before shipment, it may be found that the primary air is already in proper adjustment. However, **adjustments may vary from one location to another due to differences in elevation and in characteristics of the fuel gases.**

If the flame burns yellow or “lifts” off the burner, it needs adjustment. Take out the screws retaining the rectangular cover plate (H) and lift the plate off. Inside the opening, is a threaded rod with the visible end slotted to receive a screw driver. By turning

the rod you will adjust the position of the main burner air shutter. This air shutter should be adjusted to the point where a slight trace of yellow remains in the tip of the flame. Replace the cover and check that the yellow tips have now disappeared. **Caution: remember that the lighter opening cover and the primary air adjustment cover plate must be in place for proper operation of the furnace.**

The most common cause of heater failure is pilot outage, the inability of the pilot to stay lit unless the reset button is depressed. The trouble is usually in the thermocouple. Check to see that the end of the thermocouple lead is screwed firmly into the safety pilot valve and that the joint is clean.

The furnace can be used to circulate air during hot weather by shutting off the gas valve and turning the thermostat up higher than the temperature in the trailer. However, **be sure you return the thermostat to the OFF setting whenever the heater is not in use.**

When the humidity is high inside your trailer and you wish to remove moisture, open a roof vent and turn on a vent fan. If you do not have a fan open a window slightly to get cross ventilation.

The Bowen Gas Water Heater is equipped with a Robertshaw 100% shut-off safety valve which shuts off the gas supply if the

pilot flame is extinguished or the water temperature becomes excessively hot. **It is lighted and serviced from the outside through an access panel at the roadside, rear, of the trailer.**

Procedure for lighting or relighting:

1. **Be sure the water heater is filled with water.** Open the hot water faucet at the sink and when the water flows, the heater is full.
2. Turn the gas cock knob to the “OFF” position and the temperature indicator to the lowest temperature position.
3. Wait sufficient length of time to allow gas, which may have accumulated in the burner compartment, to escape (approximately 5 minutes).
4. Turn gas cock knob to ‘PILOT’.
5. Depress the knob and move the lever of the spark igniter back and forth between its stops until the pilot flame ignites. This may take several movements of the lever, or you may light it with a match.
6. Keep the knob depressed for 1 minute after the pilot flame ignites.
7. Turn the gas cock knob to ‘ON’.
8. Set the lever indicator for the desired water temperature.
9. To shut down the water heater, turn the gas cock to the ‘OFF’ position.

Pilot Flame Adjustment.

If the pilot flame does not have a small orange tip, the pilot is not getting enough gas. The flame should be about 1/4 inch in vertical height when the water in the tank is cold and the burner is off, 1/4 to 3/8 inch in horizontal length when the tank is warm.

A large orange flame indicates excessive gas supply, which will result in short pilot life and early replacement. The pilot has been properly adjusted at the factory and should operate with a blue, orange tipped flame enveloping the pilot thermocouple. Removal of the pilot adjustment cap in the lower right corner of the control will reveal the pilot adjustment screw. Turning this screw clockwise

reduces the flow of gas to the pilot (blue flame) and counter-clockwise, the gas supply will increase (orange flame). **Always replace the Pilot Adjustment Cap to prevent pilot leakage.**

Air Shutter Adjustment.

All fuels depend upon air (oxygen) to give them proper burning characteristics. A yellow, smoking flame indicates a lack of air and a noisy hard blue flame indicates too much air. The air shutter slides back and forth along the burner tube and is held in place by a small shutter adjustment screw. Loosen the screw for adjustment. A good method of adjusting the air shutter is to slide the shutter to the right until yellow tipping occurs on the main burner flame (not the pilot) and then slowly slide the shutter to the left until all signs of yellow tipping are gone. When proper adjustment has been obtained, tighten the screw holding the air shutter. **The access door must be kept firmly locked.**

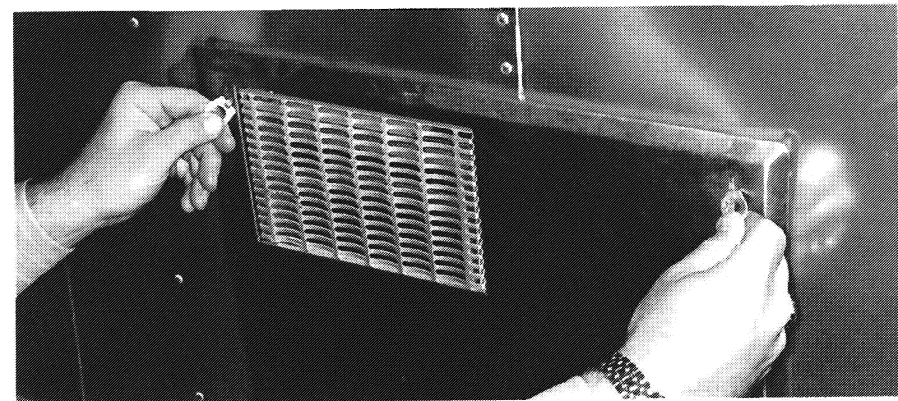
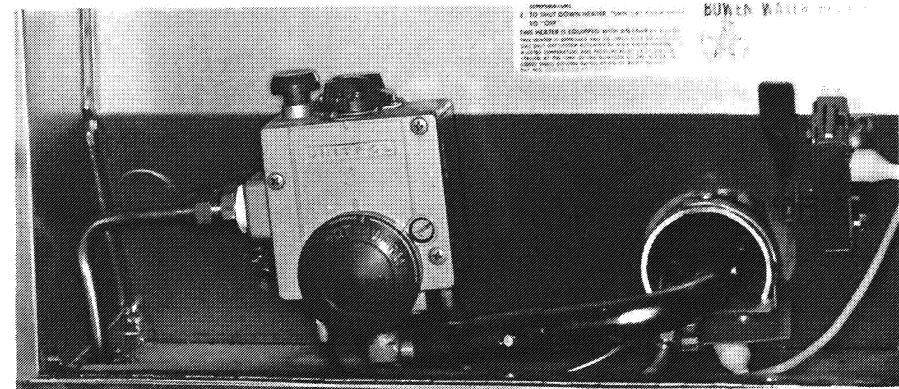

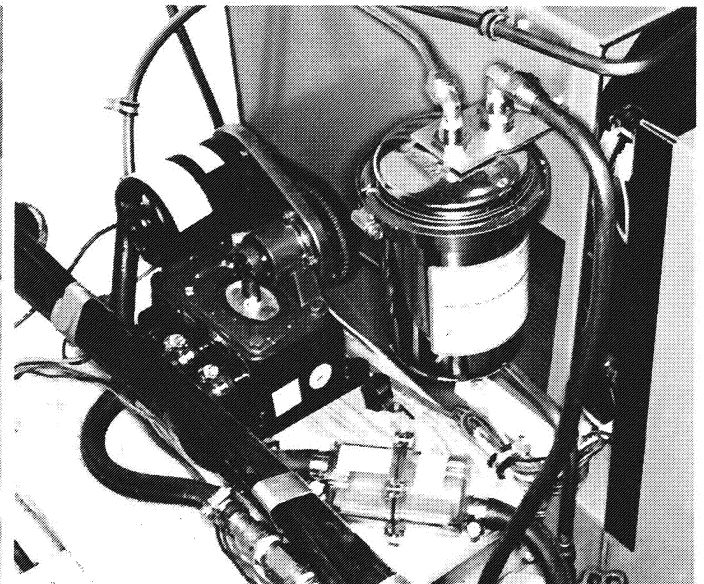
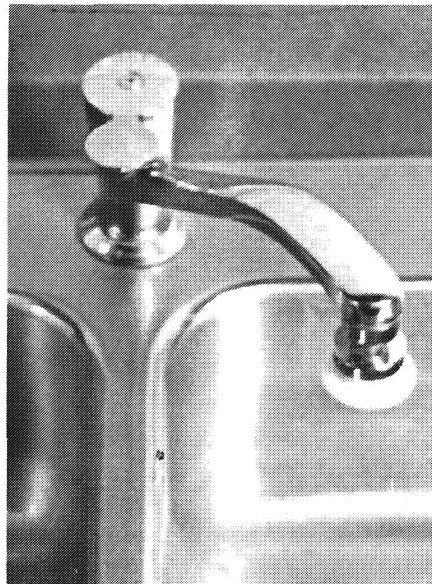

N 38-39 WATER SYSTEM

The Airstream Water System provides full service both when the trailer is self contained, or when city water is available. Water Heater capacity is 10 U.S. gallons in 25-ft. through 31-ft. units and 6 gallons in 18-ft. and 21-ft. units. The water tank stores 50 gallons of clean fresh water for all your needs.

For city water supply, connect a 5/8" high pressure hose to the water inlet fitting (see photograph) located under the rear roadside corner of the trailer, just forward of the bumper. Turn the hose on and slowly open an inside faucet until the water flows free of air. The system will now be ready for use. If you are staying for some time where city water is available, drain the water storage tank. The drain valve is accessible through a hole in the floor below the galley sink. Be sure to refill your tank with fresh water before departing. Your system has check valves in the water lines to protect the water tank while you are connected to the city water supply.

When self contained, the Water Pump should be turned on. The switch is located on the Central Control Panel above the front

roof locker of your Airstream or in the galley area. The Water Pump will run whenever a faucet is opened, and will shut off when the faucet is closed. It will deliver 3 gallons per minute under constant pressure.

Note: The Water Pump must be turned off when hooked up to city water supply and when you leave your Airstream unattended.

The water tank is located under the floor just forward of the axle. To fill the water storage tank, open the filler spout (see photo) on the exterior wall adjacent to the galley, and fill with a hose or a bucket, until the water supply pipe is overflowing. Close the spout, and the water system is again ready for use. The fresh water holding tank filler cap (see photo) may be completely removed and a 5/8" water hose inserted directly for a quicker fill-up.

To clean the tank, pour some bicarbonate of soda into the filler pipe with several gallons of water and allow to stand for a minimum of four hours. Then flush the tank out by opening the drain valve and running fresh water through it.

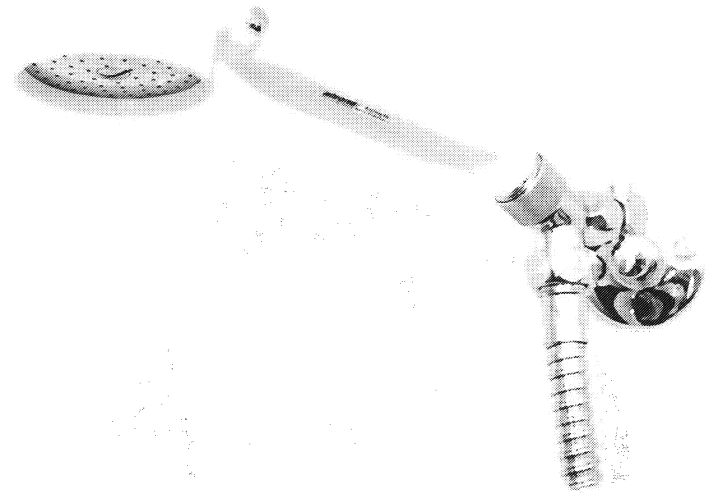
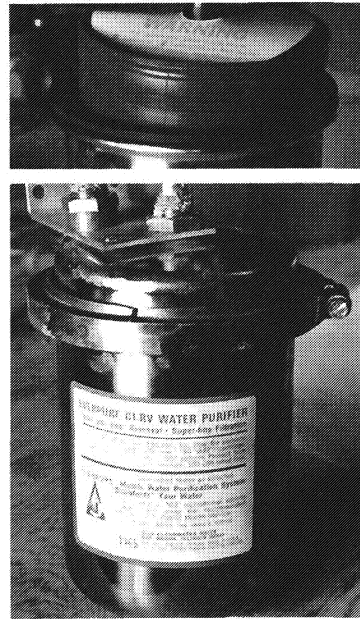
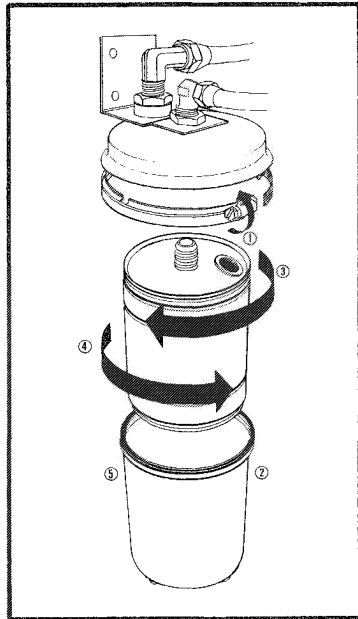
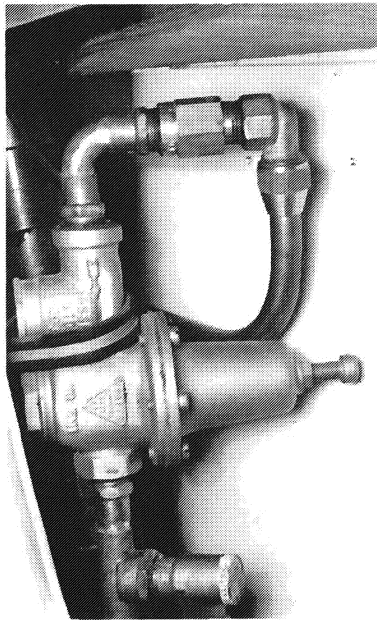

The pump and water screen are under the Galley Sink. The screen should be cleaned periodically to prevent accumulation of dirt and sand. To remove the water screen, disconnect the rubber hoses from both ends, separate the screen housing, and lift the screen out of the housing.

The Water Pressure Regulator is on the road side of the rear trunk in International units and in the aft roadside wardrobe of Land Yachts. It protects the plumbing inside your trailer, regardless of the variation in city water pressures. The pressure at the faucet is kept constant.

The Everpure EN-1 Water Purifier (standard on International models) is located under the galley sink. It will remove all dirt and colloidal matter, and eliminate most chlorine, phenol and similar odors and tastes while delivering sparkling taste-free water for drinking and cooking. The filter is connected to the cold water line only. The purifier is not guaranteed to remove the tastes and odors of iron and sulphur. To remove these tastes, chlorinate the water supply. Super chlorination will precipitate dissolved iron, and the purifier will then remove the formed chlorine salts. To

purify any questionable water add 1/6 oz. of chlorine (ordinary household bleach) per 10 gallons of water to the water tank. 5/6 oz. for a 50 gallon tank. We recommend the use of tablets available at Wally Byam Stores. The quality of the water never varies even at the end of the filter pack life, however as the minute pores slowly fill up with impurities, this will gradually reduce the rate of flow until it is necessary to change the filter. Instructions are in each box, and we advise you to buy two at a time, always keeping one in reserve.

The Telephone Shower Head is designed to give maximum flexibility of usage and to conserve water. When using the shower head, it should be held in the hand and moved about the body. Normally the best water conservation procedure is to wet the entire body and then turn the water off. Apply soap, lather thoroughly, then turn the water on and rinse the soap off your body.

On International models, the shower can be turned on and off without disturbing the hot-cold adjustment. The telephone shower head is also used to fill the tub for taking a tub bath.

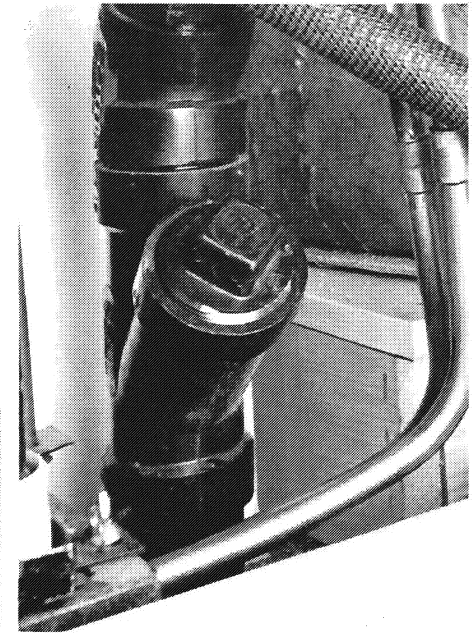
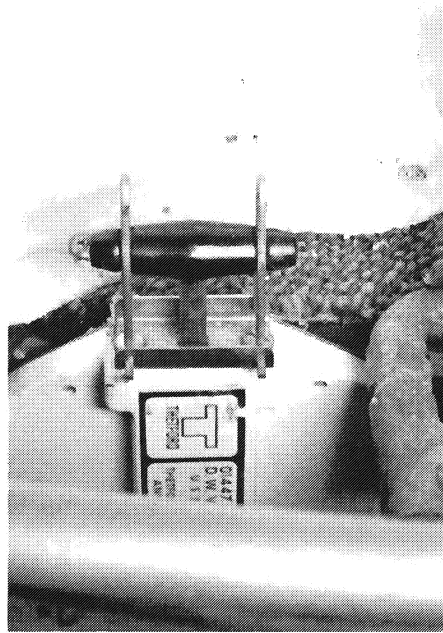
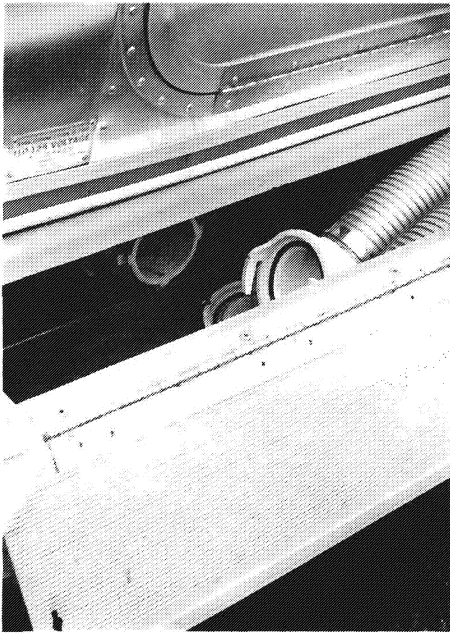

O 40-42 DRAINAGE AND VENT SYSTEM

Your Airstream has a drain, waste, and vent system similar to the system in your home. It also has a waste holding tank made from molded plastic, free from corrosion problems, with a trouble free dump valve. This tank enables you to use the toilet for several days away from disposal facilities. The waste water from the sink, the shower, bath and lavatory, bypasses the holding tank, yet drains through the same outlet as the waste and you will therefore need to make only one connection when hooking up in a trailer park with sewer facilities.

A convenient fitting for flushing the holding tank (see photo) is on the right side of the rear trunk compartment. Replace the plug after using the fitting! The sewer hose is stored in the rear bumper compartment below. Rinse out the sewer line before storing.

When the toilet will no longer drain, the tank is full and must be emptied. Watch this closely, because **when the tank is full, sewage cannot be emptied from the toilet bowl.** In models with a central

control panel, watch the tank level indicator. To empty the tank, attach the sewer hose by pressing the bayonette fitting onto the dump valve outlet and rotate clockwise until it feels solid and secure. Attach the outlet end of the hose to the sewage outlet, making sure that the hose is placed so that it will drain completely. The dump valve has two wire loops that lock the handle in the closed position. To unlock push outward on the wire loops and they will snap loose, permitting you to open the valve. Pull up the dump valve handle as far as it will go, and wait until the tank is drained. Close the dump valve and, using the flushing fitting, refill the tank with 5 to 10 gallons of clean water and repeat the operation until all paper and waste material is flushed out. The capacity of the holding tank is 21 gallons.

The Aqua Magic toilet employs a new principal: a sliding self cleaning positive seal blade. Odors cannot escape from the holding tank into the trailer. The unit uses less than 2 quarts of water for automatic flush. A special feature is the second pedal attached

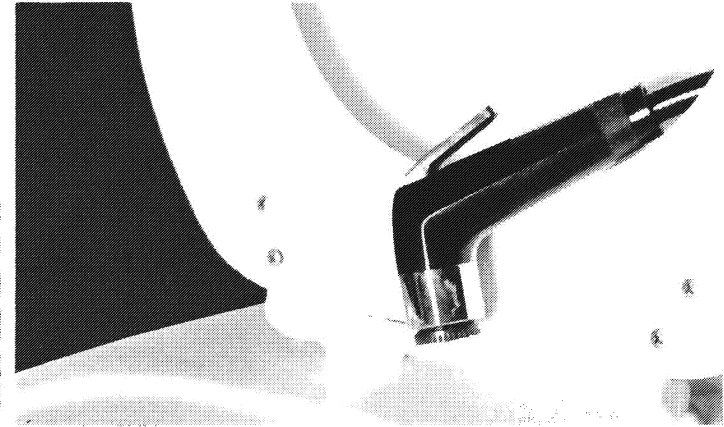

to the main foot pedal which, when pressed by itself, allows fresh water through either the fill rim or hand spray without opening the slide valve.

When conserving water, use the hand spray in the following way:

1. Hold the hand spray in ready position over bowl.
2. Depress thumb button, and step on the foot pedal, which sprays water and dumps the contents at the same time.
3. Spray bowl clean.
4. Release foot pedal, shutting off water flow.
5. If you wish to refill bowl with water for next use, depress small foot pedal till water reaches desired level.

Note . . . If you release the thumb button before the foot pedal, water will automatically flow through the rim of the bowl.

When using automatic flush:

1. Step on main foot pedal, and this will automatically open the slide valve and drop the waste into holding tank.
2. Hold pedal down until water begins to swirl. This fills rim storage and rinses the bowl.
3. Release the foot pedal. This will close the valve blade and stop fresh water from flowing. The bowl will refill automatically.

If you are certain to empty your holding tank every few days, you

can use the toilet on automatic flush. It uses very little water and the tank will provide for the requirements of two adults for from two to four days.

Whenever water is scarce, the hand spray flush, makes it possible to stay a week or longer in areas where you cannot empty your holding tank. In flushing for urine only, first, wet the bowl with fresh water, and again after use. Starting with a dry bowl takes more water for the final rinse. To flush for urine and solid matter: spray just enough water in the dry bowl to provide for floating the paper and solids. After use, rinse down the sides with the hand spray and empty the bowl. Hold the slide valve open and spray and rinse the lower surfaces. Even if it appears clean, quickly spray it one more time then release the pedal and it is ready for the next use.

When connected to a sewer outlet or a gopher hole, keep the holding tank dump valve closed and empty the tank every few days or whenever it becomes almost full. Only by sending a large volume of liquid through the holding tank at a time will toilet paper and other solids completely wash away. This practice will avoid the accumulation of solids in the holding tank which could lead to an unpleasant cleaning job. If it ever happens to you, close the dump valve, fill the tank about half full with water then tow the trailer for a few miles. The turbulence and surging of the water

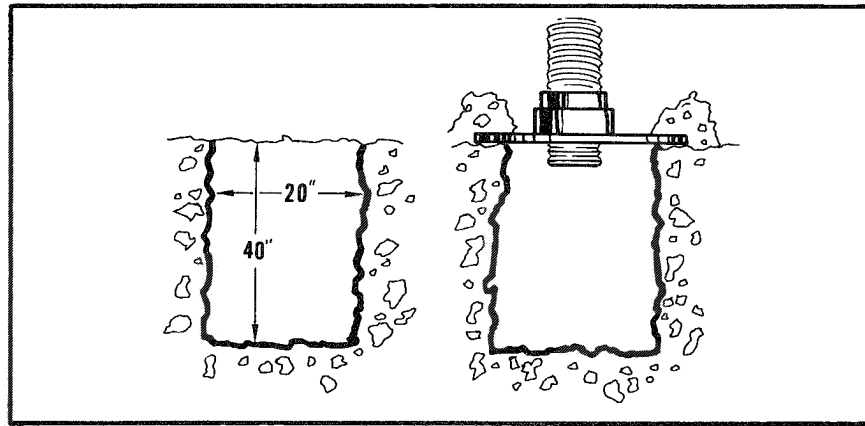

will usually dissolve the solids into suspension so the tank can be drained.

In areas where there are no sewer outlets available and gopher holes are permitted you should dig a hole 18" to 20" diameter and 40" deep, for emptying your waste holding tank (see illustration). Keep the earth you dig from the hole and use it to fill the hole when you leave. Back your trailer up in such a way that no one can accidentally step in the hole. Use a hole cover, 22" square with a 3" diameter cut-out in the center. The drain hose should always be able to drop straight down through this cut-out. Make a dike to prevent rain from washing in and seal the hole by piling earth around the edges of the cover. It is good practice to drain your holding tank the night before leaving. The ground will absorb most of the contents overnight and filling in the hole in the morning will be much easier.

There are certain items that you should never put into the toilet or tank. Facial and other similar tissues: because they have wet strength and do not dissolve easily. Toilet paper, especially white, dissolves well after a period of traveling.

Detergents and bleaches should not be used as deodorizers because they may damage your tank. Use a trailer sewage tank deodorizer instead. Antifreeze, Ammonias, Alcohols and Acetones may cause

damage to your tank, valve parts, tank fittings, and drain hose. For protection against freezing, use recommended fluids. (see section "H")

Dishwater and Washwater, as they contain detergents which attack the system, should not be dumped into the tank. Some state and federal parks prohibit draining sinks and bathwater into the ground, though this is done in the wilderness. We suggest you use a pail under the drain outlet and discard the water in a public bathroom.

Although we do not recommend the following practice for reasons stated above, in an emergency or unusual parking situation, you may empty waste water from the sink and lavatory into your waste holding tank instead of allowing it to drain onto the ground. To empty waste water into the waste holding tank, open the dump valve while keeping the sewage line drain cap on. Waste water will automatically back up into the tank. Note: Water conservation must be practiced as holding tank will fill rapidly. After you have been draining waste water into the holding tank and wish to drain the holding tank, place a bucket under drain outlet, close the tank dump valve and remove the drain outlet cover cap. This will drain the section of pipe between the cap and the valve and any adjacent drainage lines that might have filled with waste water. Next, drain the holding tank following the instructions at the beginning of this chapter.

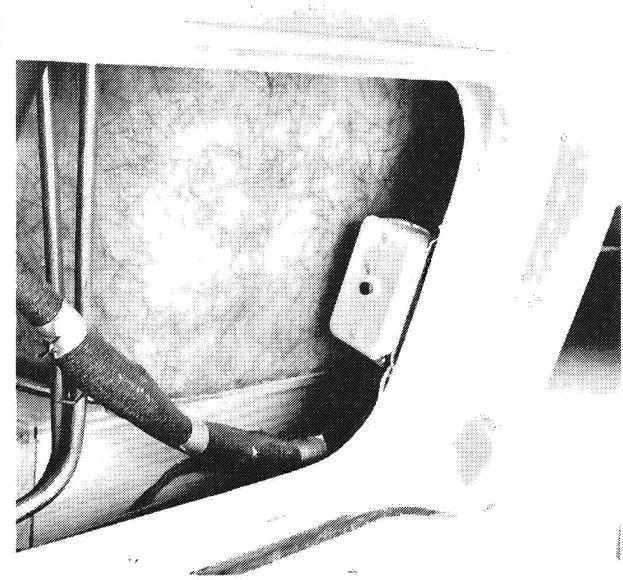
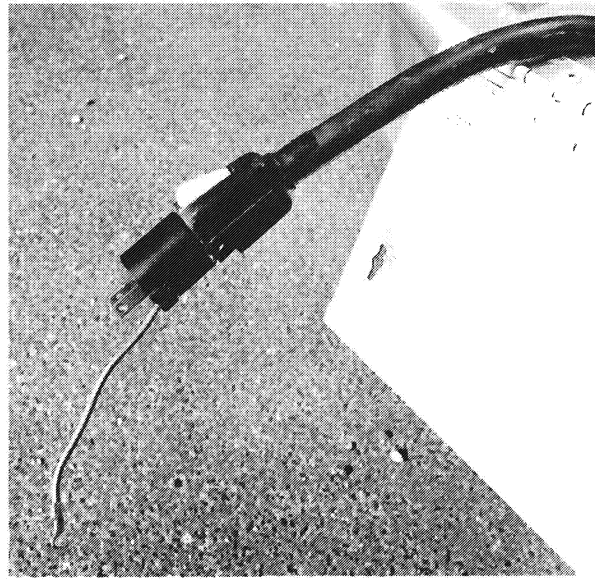
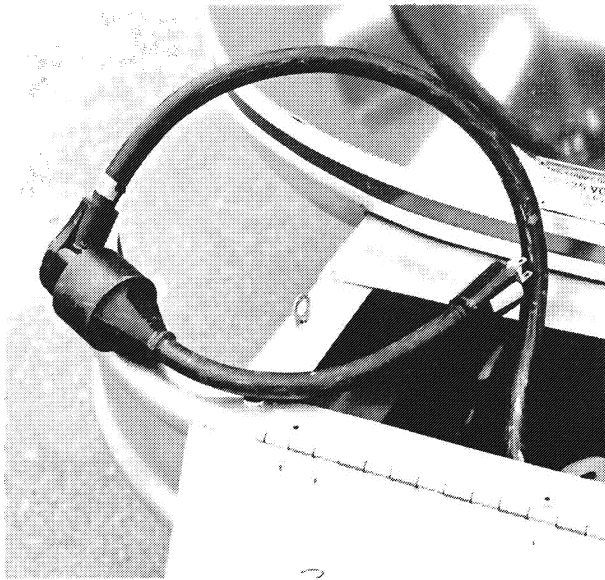

P 43-48 ELECTRICAL SYSTEM

The exclusive **Airstream Univolt System** enables you to use your lights and appliances whether you are operating on self contained battery power or hooked up to 120 volt city power. This combination unit contains all solid state circuitry and is protected from damage by internal automatic resetting circuit breakers. The 12 volt light bulbs give off the same light as regular household bulbs, so that when operating on self contained battery power, everything works normally except the 120 volt convenience outlets and the electrical operation of the refrigerator.

When operating with city power, make very certain that the service is 120 volts and not 220. Open the bumper storage compartment lid, uncoil only the needed amount of cord, pull it through the access door on the bottom of the storage compartment, and plug it into the city power source.

When the three pronged plug can be used, you will have no problem with proper polarity or grounding. In some older parks and other locations where three pronged outlets are not available, you must take certain precautions to insure proper grounding and polarity.

1. Attach the three pronged plug to a two prong adapter. The third conductor line of this adapter has a short wire lead which constitutes your ground line.
2. If possible, clamp the ground line to the junction box or to a water pipe, and then insert the two prong plug into the receptacle.
3. Check the polarity light in your rear trunk compartment. If it is on, pull out the plug, turn it over and reinsert. The light will now be out.

When no water pipe is available, experienced trailering people will drive a metal rod two feet into the ground and attach the ground lug to it thus providing the unit with proper grounding.

The polarity warning light indicates improper polarity and it should be off when the power supply cable is used with a two pronged adapter. It may occasionally glow when the three wire system is in use, but your trailer is properly grounded, and in this case you may ignore the light.

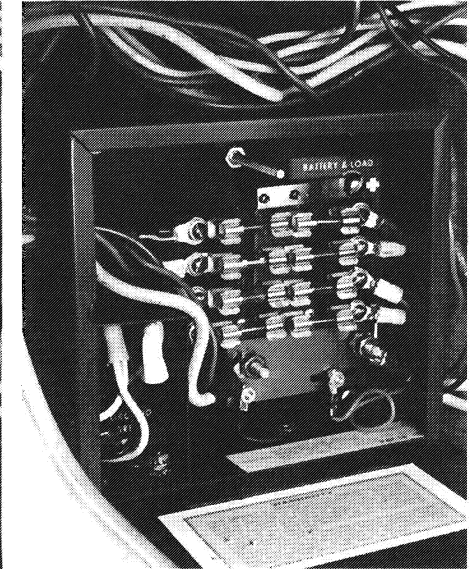
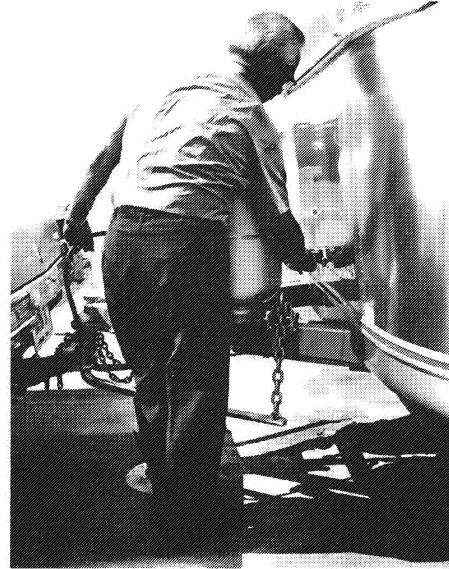
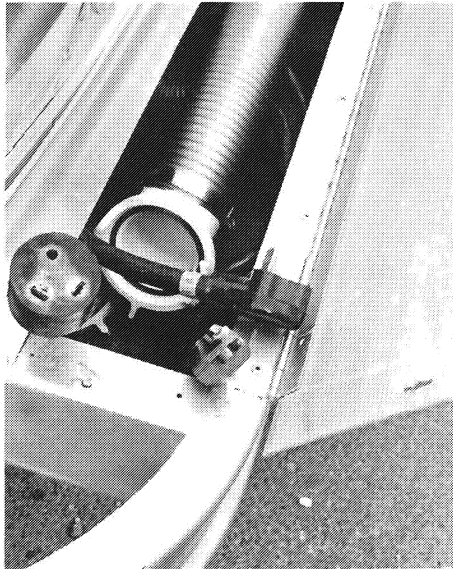

To operate self contained, simply disconnect the power supply cable from the city power receptacle. Store the supply cable in the space provided for it in the hose storage compartment.

When being towed, the 12 volt battery in your Airstream is receiving a constant charge from the car's generator and alternator through the **Seven Way Connector**. The charge rate is controlled by your automobile's voltage regulator. It is important to keep the seven way connector clean and as previously mentioned, one method is to use Spra-Kleen.

When your Airstream is hooked up to 120 volt A.C. the **Univolt System automatically charges your trailer battery** and, if it is hooked up, your automobile battery as well. The speed and degree of charge depends on how much power is used for lights and appliances, as only the surplus goes to charging the battery. (Please refer to the specifications section for more information on power consumption.)

Whenever possible, use the automatic built-in charger of the Univolt System for charging. There is a voltage sensing section in the charger circuit that automatically controls the current, shutting

it off when fully charged. At service stations, make certain they give your battery a slow charge because quick charges will drastically shorten the life of the battery as will allowing repeated complete discharges.

A normal battery will discharge by itself in 30 to 45 days, therefore, **it is necessary to periodically check the battery and charge it as is necessary.** We suggest checking the battery at least every two weeks in freezing weather. A fully charged battery will not freeze under any normal circumstances, therefore, it is imperative that you keep your battery charged during the winter. A safe level of charge is a specific gravity reading of 1.225. A fully charged battery has a specific gravity of 1.250 to 1.280.

When you are traveling steadily and for an extended period of time you should check your battery bi-weekly for water and condition. If you are making an extended stay or storing your Airstream, then **you should (if it is available) keep your trailer hooked up to 120 volt current.** This, through the Univolt System, will keep your battery charged and you should check it every two weeks for condition and water.

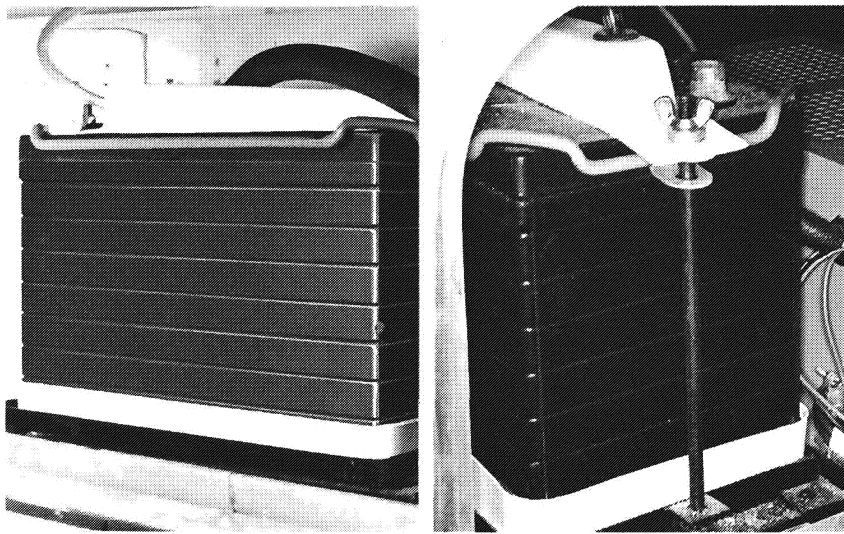

During the winter, your battery should be removed from the Airstream and stored in a warm place, kept full of water, and charged monthly. A battery which is allowed to completely lose its charge will never regain its original power, or a full charge.

The battery is in the rear trunk compartment, mounted on a pivoting rack for easy servicing in 27 through 31 foot units and in the rear curbside compartment in the 18 through 25 foot units. For battery service or replacement, go to any service station or dealer who sells and services this battery. There is a 24 month pro-rated warranty on your battery.

The Central Control Panel, located above the front roof locker of your unit, contains the necessary instrumentation to monitor your Airstream's systems.

The Panel Light switch lights up the panel and makes an excellent night light.

The Clock is operated by a 'C' cell battery which will last from nine months to a year. Reset the time and change the battery from the rear of the panel.

The Battery Condition Tester has a switch which operates a meter

indicating: Good condition at 12-13 volts, fair at 11-12 volts, and bad at 10-11 volts. (This meter does not indicate true battery condition while you are hooked-up to 120 volt city power.) When it shows bad condition, you should take every reasonable step to conserve power by using as few lights as possible and switching off appliances.

The Ammeter indicates whether the trailer battery is being charged. If discharge is indicated, reduce your power usage. The Univolt System, as we have previously mentioned, charges the battery only to the extent of any surplus over and above the electrical demands you make. Therefore, we recommend that you test your battery before leaving, and after disconnecting the 120 volt line.

The Water Pump Switch, when on, also lights up the indicator light. On trailers without a Central Control Panel, this switch is in the galley area. The switch activates the water pump and for a complete discussion of the pump please refer to section "M".

The Water Level Indicator Lights show the amount of water in the water tank. Press the button and the light will show: "1/2" when the tank is at least half full, "1/4" when the tank is at least 1/4 but less than half, and "0-0" when it is less than one quarter full. If no lights show, the tank is nearly empty. In rare cases, when

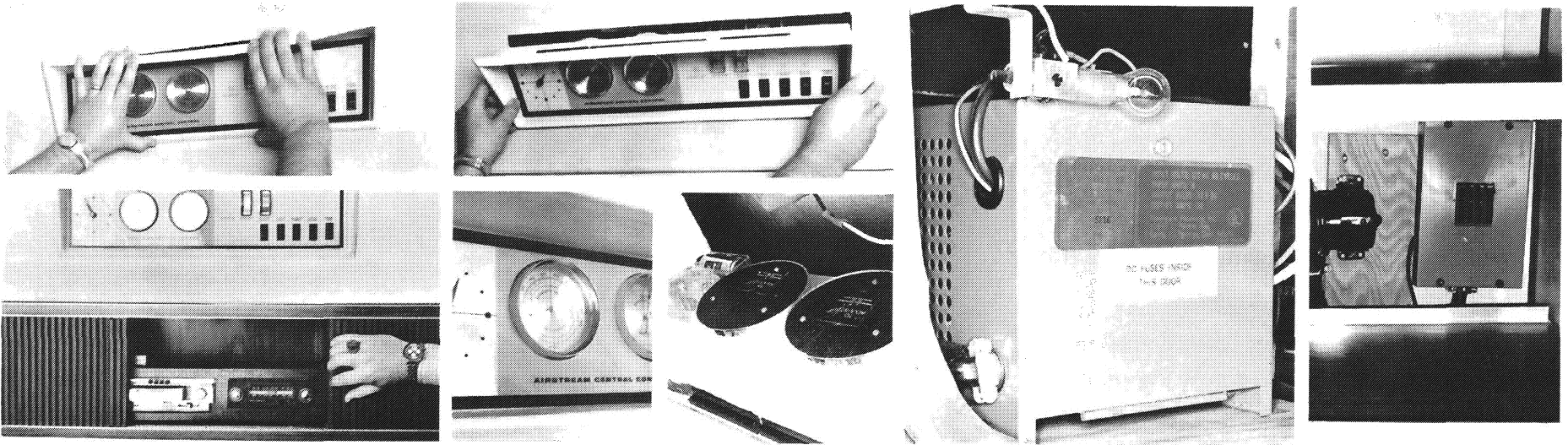

the tank has been filled with very pure water, as from a mountain stream, the indicator lights may not work at all.

The Holding Tank Level indicates “1/2” when it reaches half full, and “4/4” when it reaches the three quarters full mark.

The Power-On Light will glow automatically when you are hooked up to city power. This light and the polarity warning light are your checks on a proper 120 volt connection.

The Barometer should be adjusted for your altitude by rotating the small screw within the hole marked ‘adjust’ to agree with the reported local barometric pressure. Refer to the weather station forecasting guide in section “R”.

Your Humidity Meter is adjusted by rotating the slotted metal piece, visible through the center hole, with a screw driver until the meter agrees with local conditions.

Access to the rear of the Central Control Panel is necessary for replacement of: the clock battery, panel light bulbs, water pump fuse, and the adjustment of the Barometer, Humidity Meter and Clock. To get behind, remove the attaching screws, grasp the center, pull down, and swing the panel out and forward. (see photos)

The Univolt is at the rear curbside of the trailer, accessible through the curbside access door. The 12 volt fuse panel is in the Univolt case. (see illustration)

The 120 volt circuit breaker panel is in the rear roadside wardrobe. In the event of failure of a 120 volt circuit, check your circuit breaker first. While you are connected to the 120 volt receptacle, the wiring is protected by circuit breakers in the breaker panel. If a breaker continues to trip after you have reset it several times, your circuit may be overloaded with appliances or there may be a short in the circuit. If lessening the load does not solve the problem consult an Airstream Service Center or the factory.

The Univolt System and the Central Control Panel are provided with a series of fuses (see illustrations) for the safety of you and your unit. Trouble with the electrical system is extremely unlikely, but if it should occur we recommend that you contact your nearest Certified Service Center for repairs. We have included a trouble shooting chart to be used in emergencies only.

Details of electric motor amperage, light bulb size, and fuse and circuit breaker locations are shown on the specifications chart in section “R”.

TRAILER CAR CONNECTOR

a: Battery b: Ground c: Right Turn & Stop d: Running Lights e: Left Turn & Stop f: Brake g: Backup Lights h: Charge Line j: Univolt k: Resistor l: Brake Controller m: Voltage Regulator n: Generator

Note: Polarity of trailer battery must match polarity of car battery. e.g. If negative pole of car battery is grounded, negative pole of trailer battery must be grounded.

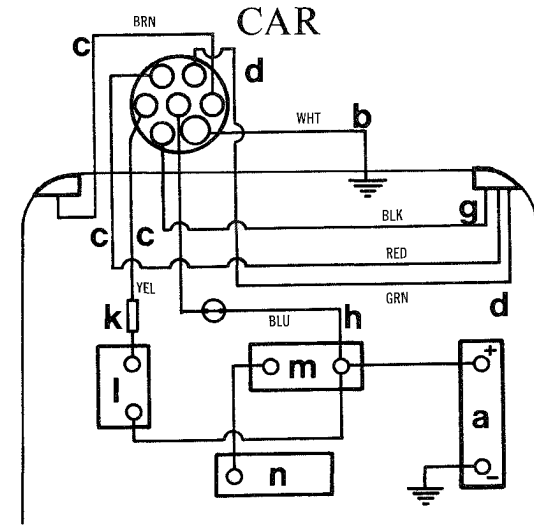
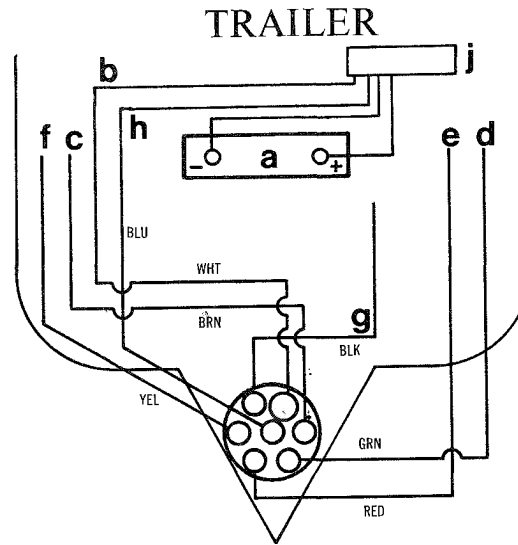

SYMPTOM	POSSIBLE CAUSE	REMEDY
No. 12-volt power (Lights, appliances do not work)	1. Input line and/or battery not connected 2. 40 AMP fuse blown (univolt)	1. Make necessary connections 2. See items 3, 4, 5, and 6
Blown fuse	3. Overloaded circuit (over 40 amps) 4. Electrical short 5. Shorted battery 6. Battery terminals not properly connected to UNIVOLT + and - terminals	3. Turn off switches to reduce load Replace blown fuse in Univolt 4. Find blown fuse in Univolt and identify circuit From wiring diagrams check the circuit for defective wiring, lamps or motors 5. Replace battery and fuse 6. Make proper connections; replace fuse
Univolt automatic circuit breaker clicks on and off	7. Incorrect input line voltage (such as 230 volts or improper cycle power) 8. Shorted battery	7. Connect to 120-volt, 60-cycle power 8. Replace battery
Dim lights or sluggish fan motor	9. 25- or 55-cycle power (some foreign countries) 10. Discharged battery (when operating without 120-volt line)	9. Use 60-cycle power 10. Charge battery
UNIVOLT will not charge battery	11. Input line not connected 12. Battery not connected 13. Bad battery 14. Too many lights and appliances in use	11. Connect input line 12. Connect battery to UNIVOLT 13. Replace battery 14. Reduce electrical load
Specific gravity of battery is too high (over 1.275)	15. Battery is low on water	15. Add distilled water to battery

LOW VOLTAGE DISTRIBUTION PANEL

- | | |
|----------------------|----------------------|
| a: Car Battery | h: Negative Load |
| b: Trailer Battery + | j: Trailer Battery — |
| c: Power-On-Light | k: Ammeter |
| d: Circuit #1 | l: 40-amp-Fuse |
| e: Circuit #2 | m: 1-amp-Fuse |
| f: Circuit #3 | o: 20-amp-Fuse |
| g: Circuit #4 | |

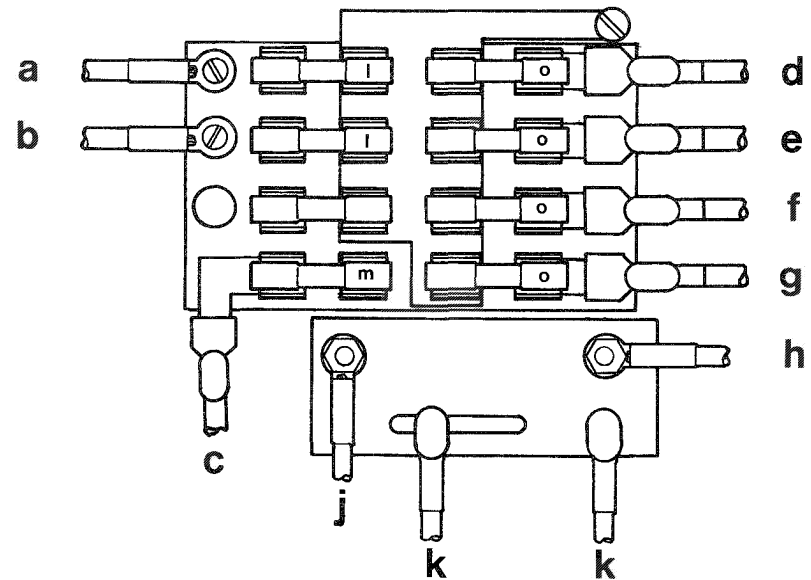

CENTRAL CONTROL PANEL

- | |
|--------------------------|
| q: Printed Circuit Board |
| r: Power-On |
| s: Ammeter Shunt |
| t: 12 V — |
| v: Water Tank Probe |
| w: Holding Tank Probe |
| x: Water Pump |
| y: 12 V + |

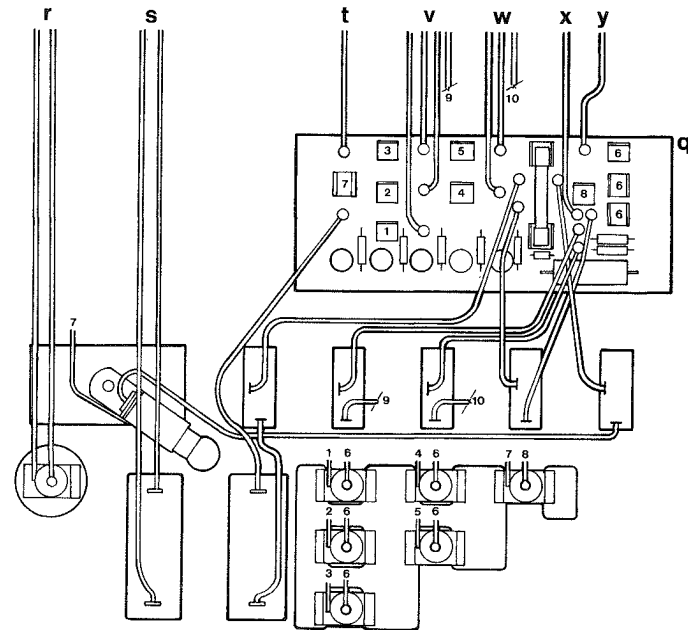

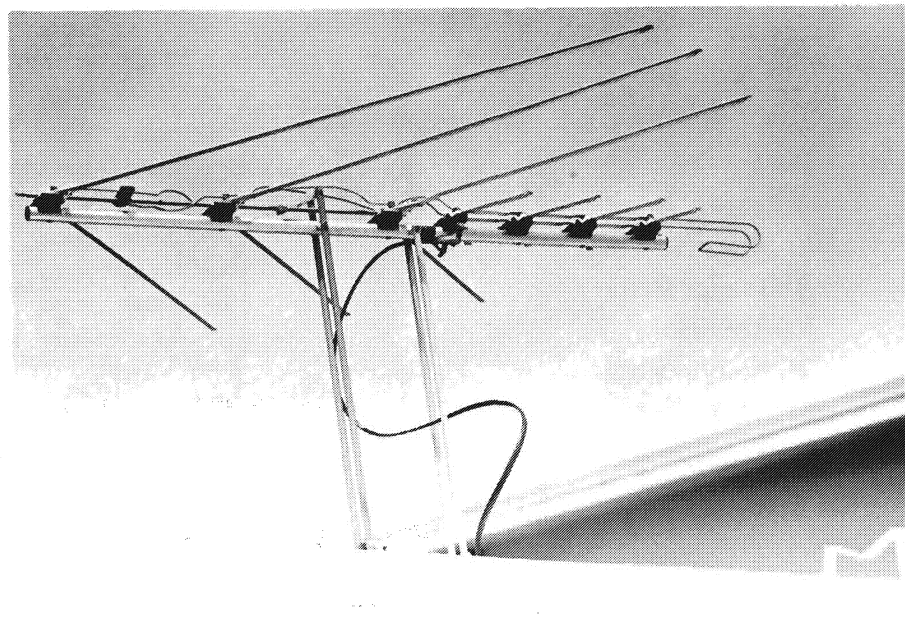

Q 49-50 OPTIONS

There are many factory options and accessories available. Ask your dealer's advice, and be sure to visit a Wally Byam Store.

The aluminum construction of your trailer creates a radio-shield and you will need outside antennas for perfect reception.

T.V. Antenna: The controls are on the ceiling directly below the antenna. To open dipoles and raise the antenna, turn hand crank (see photo) in direction indicated. Then turn on your TV set and select a channel. While watching the picture, rotate the round flat disc on the antenna control until the picture is good. If you hit a stop before the picture is good, reverse rotation. When changing channels, you may have to readjust again. To close, reverse the direction of hand cranking, and check outside that the antenna is folded and pointed straight forward.

A police-type telescoping whip-Radio-Antenna is available for 12V AM-FM transistor radio and should be professionally installed next to the front window roadside, of your trailer, on a swivel

mount.

The Bay Breeze Airconditioner requires expert installation. Please let your Airstream dealer or one of our factories install it.

Air conditioner High and low speed setting. To operate: 1) close doors, windows and ventilators. 2) Set thermostat to desired temperature (75° is normal). Do not make frequent changes. 3) Set the fan switch (left under thermostat) to HI position. 4) Set main switch (right under thermostat) to 'cool'. When the inside temperature has reached the thermostat setting and the outside temperature is 90° or less and expected to continue, set speed to LO.

To shut down: Set main switch to 'OFF'.

Shut off to clean or replace the filter. To clean, brush off loose lint, run water through filter or move it briskly in soapy or detergent water. Rinse thoroughly. Dry completely and replace. The unit has a low voltage starter kit, so that it can start at 90 Volt current.

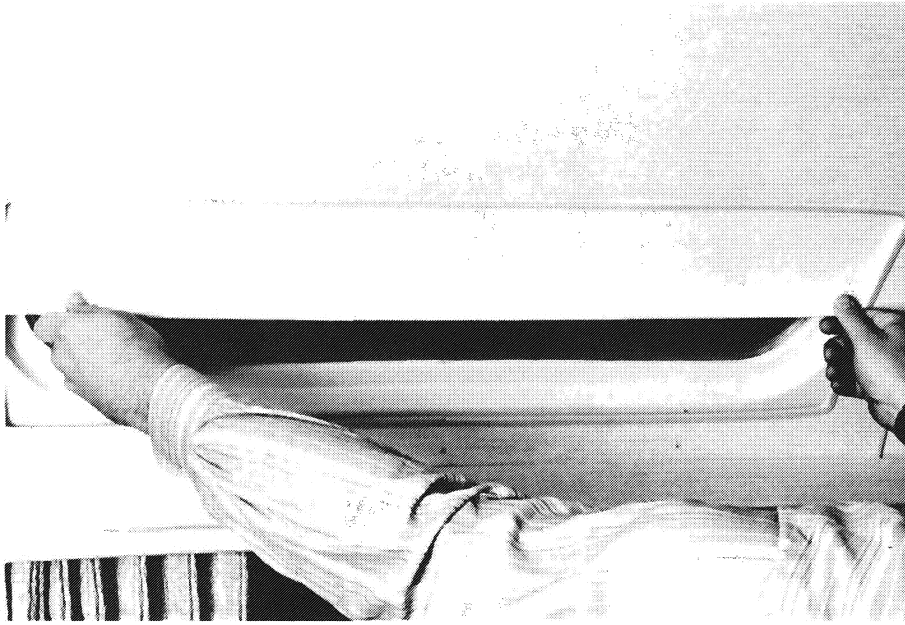

Vistaview Windows, an exclusive Airstream feature, are skylight windows equipped with integral shades that can be completely closed.

If you plan to use your Airstream in cold weather, such as for skiing, we recommend the custom **Airstream storm windows**, available through Wally Byam Stores. These storm windows lower the minimum outside temperature, in which you can remain comfortable, by about 10°F. They also help to keep the trailer cooler in extremely hot weather and thereby increase the effectiveness of the Bay Breeze air conditioner.

Awnings give shade during trips and rallies, are easily operated and swiftly installed by your dealer from a wide selection.

Step Extension: This convenient addition slips easily into place on the standard fold-away step making access easier when the terrain causes the trailer hitch to be raised particularly high.

The electric jack is strongly recommended for anyone who, for

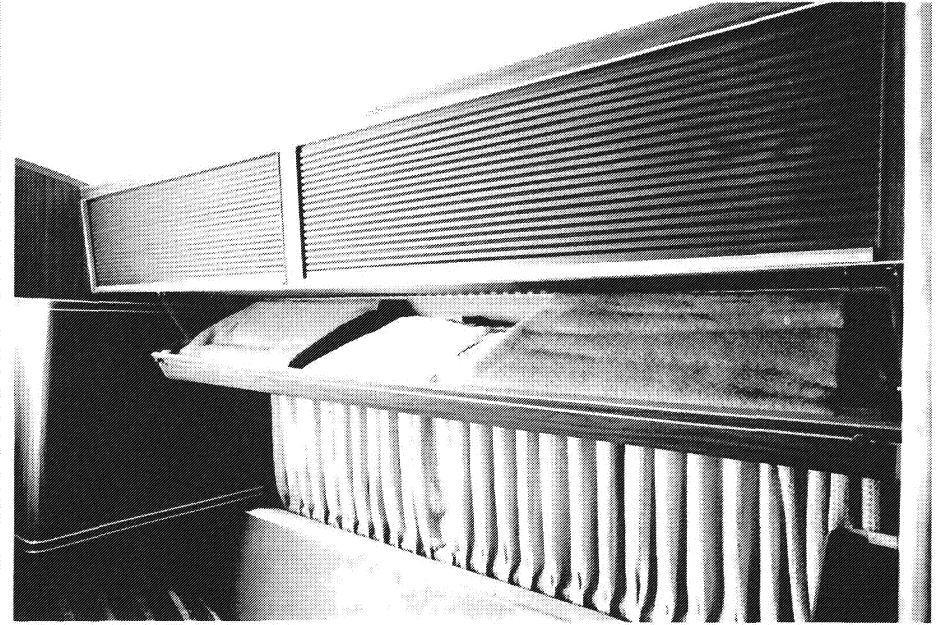

any reason, should not physically exert himself. Available as a factory option or through the Wally Byam Stores, the electric jack makes hitching and unhitching a much easier operation, even for the wife.

For added sleeping space, **fold-away bunks** can be installed in many ways, and stored out of the way when not in use. Let your dealer advise you what is best for your particular needs.

A Battery pack (dual battery) is available and can be installed in your car trunk if your trailering plans include long periods of self containment.

You may want additional storage space for bedding, etc. in the bedroom. A **drop-down locker** attached to the roof lockers is available for this purpose.

In addition to the above, you will find many other accessories to make your trailering more enjoyable, available at Wally Byam Stores and your dealer. As you travel you will develop your outfit to suit your particular needs.

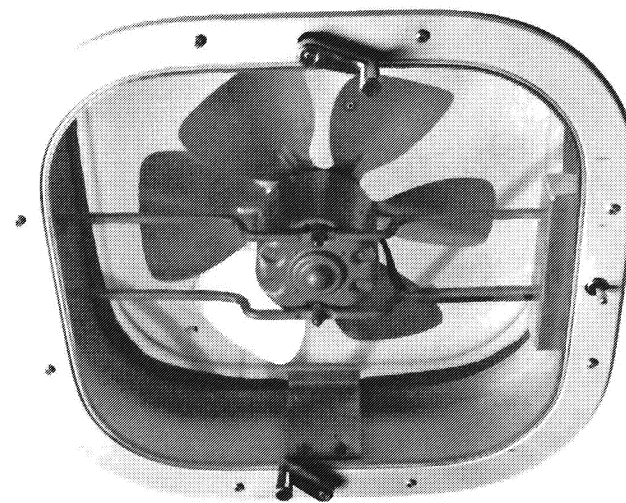
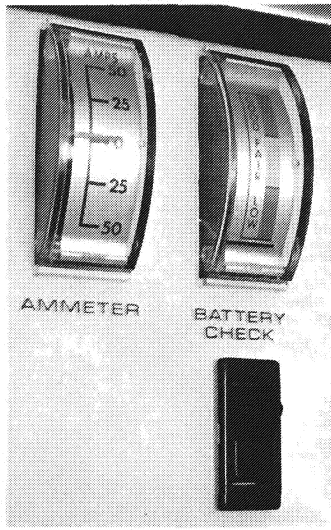

R 51-56 SPECIFICATIONS

This chart shows Light and Appliance Amperages, from which you can tell how much to deduct from the hourly Univolt output (45 amps in Land Yachts and Internationals) to determine the surplus power that will be available to charge the battery.

ITEM	AMPERAGE	ITEM	AMPERAGE
CONTROL PANEL LIGHT1	READING LIGHTS: Living Room, Bedroom6 each bulb
WATER PUMP (Internationals & Land Yachts)	9.9 max.	MAIN DOOR LIGHT6 each bulb
CEILING FAN	4.8	CEILING LIGHT (4 Bulbs):	
BATHROOM EXHAUST FAN	2.0	Living Room, Galley, Bedroom, Bathroom	1.7 each bulb
RANGE EXHAUST FAN	2.0	GALLEY FLOOD LIGHTS	
FURNACE FAN	4.5	(Internationals Under Roof Locker)6 each bulb
		GALLEY LIGHT (L.Y. Under Roof Locker)	1.7 each bulb
		TRUNK LIGHTS: Service Center, Trunk	1.5 each bulb

Note: When self-contained, conserve battery power for Water Pump, Lights and Furnace Fan.

B.T.U. RATINGS		
APPLIANCE	MODEL	B.T.U.
Furnace	27 ft. thru 31 ft.	30,000
	23 ft. thru 25 ft.	22,000
	18 ft., 21 ft.	16,000
Oven (only)	27 ft. thru 31 ft. (Int'l)	12,000
Range Top (only)	27 ft. thru 31 ft. (Int'l)	28,000
Range — Oven	23 ft. thru 25 ft.	23,600
Range — Oven	18 ft., 21 ft.	23,600
Refrigerator	27 ft. thru 31 ft.	1,345
	18 ft. thru 25 ft.	950
Water Heater	25 ft. thru 31 ft. (Int'l)	12,600
	18 ft. thru 25 ft. (L.Y)	8,800

FUSES & CIRCUIT BREAKERS

CIRCUIT	LOCATION	RATING
Air Conditioner & Other 120V Circuits	120 volt panel	20 amp C.B. (man. resetting)
Charge line from Car	Univolt	40 amp fuse
Low Voltage Circuits	Univolt	20 amp fuse
Trailer Battery Fuse	Univolt	40 amp fuse
Power On Circuit	Univolt	1 amp fuse

CAPACITIES		
APPLIANCE		CAPACITY
Waste Holding Tank	(Int'l)	21 gal.
Waste Holding Tank	(L.Y.)	14 gal.
Water Tank	(Int'l)	50 gal.
Water Heater	25 ft. thru 31 ft. (Int'l)	10 gal.
Water Heater	18 ft. thru 25 ft. (L.Y)	6 gal.

LIGHT BULB REPLACEMENT

LOCATION	LAMP NUMBER
Reading Lights (living room)	1383
Reading Lights (bedroom)	1141
Galley & Vanity Flood Lights (Int'l)	1383
Galley & Vanity Lights (L.Y.)	1141F
Ceiling Lights	1141F
Central Control Panel Light	53
Door Light	90
Service Center & Trunk Lights	1141
Clearance & Cluster Lights	1895
Stop & Turn Signal	1034
License Plate Light	89
Backup Lights	1073

LUBRICATION & MAINTENANCE

ITEM	Every 1,000 miles or 30 days	Every 5,000 miles or 90 days	Every 10,000 miles or 6 months	PROCEDURE
Battery	X			Check water level – fill with distilled water only.
Smoke Hood	X			Clean fan blades and wash filter.
Hitch Ball Latch	X			Lubricate with engine motor oil.
Hitch Jack	X			Lubricate with light household oil (put oil can spout up under handle and allow oil to run down post).
7-way Plugs & Receptacle		X		Clean contacts and coat with “SPRA-KLEEN.”
LPG Hold Down Knob	X			Lubricate with light household oil.
Entrance Door Hinge	X			Lubricate with light household oil.
Roof Vent Elevator Screws	X			Lubricate with light household oil.
All Exterior Door Locks	X			Lubricate by shooting in dry graphite.
Strike pocket on Main Door	X			Coat with paraffin.
Wheel Bearings			X	Clean, repack, and adjust.
Brakes			X	Inspect and adjust.
Tires	X			Check for foreign objects. Check air pressure.
Water Pump		X		Check belt for wear and proper tension.
Wheel Lug Nuts		X*		Check for tightness.
Retracting Step		X		Lubricate moving parts.
Window Seals/Door Seals		X		Clean with mild detergent & coat with “Slipicone.”

*NOTE: On new trailers check lug nuts every 200 miles for the first 1,000 miles.

HOW TO USE BAROMETER Weather Station FORECASTING GUIDE

Wind Direction	Sea-Level Barometric Pressure in Inches	Character of Weather Indicated
SW to NW	30.10 to 30.20 and steady	Fair, with little temperature change for 1 to 2 days.
SW to NW	30.10 to 30.20 and rising rapidly	Fair, followed within 2 days by rain.
SW to NW	30.20 and above and stationary	Continued fair with no marked temperature change.
SW to NW	30.20 and above and falling slowly	Fair for 2 days with slowly rising temperature.
S to SE	30.10 to 30.20 and falling slowly	Rain within 24 hours.
S to SE	30.10 to 30.20 and falling rapidly	Wind increasing in force, with rain within 12 to 24 hours.
SE to NE	30.10 to 30.20 and falling slowly	Rain in 12 to 18 hours.
SE to NE	30.10 to 30.20 and falling rapidly.	Increasing wind, and rain within 12 hours.
E to NE	30.10 and above and falling slowly	In summer, with light winds, rain may not fall for several days. In winter, rain within 24 hours.
E to NE	30.10 and above and falling rapidly	In summer, rain probably within 12 to 24 hours. In winter, rain or snow, with increasing winds.
SE to NE	30.00 or below and falling slowly	Rain will continue, 1 to 2 days.
SE to NE	30.00 or below and falling rapidly	Rain with high winds, followed within 36 hours by clearing, and in winter by cold.

PRE-TRIP HOME-CHECK LIST

- Leave key with your neighbor.
- Store valuables and important papers in a safe place.
- Discontinue newspaper, milk and other deliveries.
- Ask the Post Office to hold your mail for you.
- Arrange with the Telephone Company for discontinued or 'Vacation Service'.
- Arrange care for your pets.
- Have your lawn, garden and house plants cared for.
- Lock all windows and doors securely. Keep shades open for a lived-in look.
- Cover all food to keep out mice and insects.
- Eliminate all fire hazards. Place matches in a tin box or glass jar.
- Store oil, gasoline and other inflammables properly.
- Destroy all newspapers, magazines and oily rags.
- Notify police.

PERSONAL ITEMS

- Automobile insurance to cover you and your family fully.
- Avoid Cash. Use travelers checks and Credit Cards.
- Confirm reservations.
- Have sunglasses for everyone.
- Pack cameras and films.
- Make a check list of clothing for everyone, & toilet articles.

MOTORING ESSENTIALS

- Display car and trailer registration properly.
- Carry drivers license. In Canada you will need a non-resident liability insurance card.
- In Mexico you must have special auto insurance.
- Carry an extra set of ignition and trunk keys in a separate pocket, or in your wallet.
- Keep an operating flashlight with fresh batteries in the glove compartment.
- Pack the trunk so that you can reach the tools and spare tire without completely unpacking.
- Keep sharp or hard articles securely packed wherever they may be.
- Do not pack things in the passenger sitting area, you need maximum space for comfort.
- Wear easy-wash, drip-dry traveling clothes.
- Do not make your vacation trips a mileage marathon! Stop and relax frequently.
- Carry a first aid-kit.
- Carry your pets dish, food, leash and health and registration papers.

AIR CONDITIONER.....	49	ELECTRIC JACK (HITCH).....	50	MOTING CHECK LIST.....	55	SWITCHES: LIGHTS.....	26
ALUMINUM SHELL.....	23	EQUIPMENT LIST.....	7	OVEN.....	32	TANK (SEWAGE).....	40
AMMETER.....	45	EXTENDED STAY.....	14	OVEN CLEANING.....	34	TANK (WATER).....	38
AMPERAGE CHART.....	51	EXTENSION STEP.....	24	OVERHEATING.....	12	TELEPHONE SHOWER HEAD.....	39
AUTOMATIC REGULATOR.....	28	EXTERIOR.....	23	OVERNIGHT STOP.....	14	TIRES.....	22
AXLE.....	21	EXTERIOR CHECK LIST.....	54	PANEL SWITCHES.....	45	TIRE PRESSURES.....	22
BACKING.....	13	FACTORY SERVICE.....	3	PILOT ADJUSTMENT:		TOILET.....	40
BALL (HITCH).....	9	FAN SWITCH.....	27	FURNACE.....	36	TOWING TIPS.....	11
BAROMETER.....	46	FILTER (AIR CONDITIONER).....	49	OVEN.....	33	TRAILER STORAGE.....	20
BATTERY.....	44	FLAT TIRES.....	16	RANGE.....	32	TROUBLE SHOOTING:	
BATTERY CONDITION		FOLDAWAY STEP.....	24	REFRIGERATOR.....	31	ELECTRICAL.....	47
TESTER.....	44	GAS (LPG) SYSTEM.....	28	WATER HEATER.....	37	FURNACE.....	36
BRAKE CONTROLLER.....	21	GAS TANK.....	28	PERSONAL CHECK LIST.....	55	RANGE & OVEN.....	32
BRAKES.....	21	GENERAL TIPS.....	11	POWER ON.....	46	REFRIGERATOR.....	31
B.T.U. RATINGS.....	52	GOPHER HOLE.....	41	POLARITY LIGHT.....	43	WATER SYSTEMS.....	38
BULBS		GROUNDING.....	43	RANGE.....	32	TV ANTENNA.....	49
(REPLACEMENT).....	52	HITCH.....	9	RANGE CLEANING.....	34	UNIVOLT.....	43, 46
CAPACITIES.....	52	HITCH BALL HEIGHT.....	9, 10	REFRIGERATOR.....	27, 29	VISTA VIEW WINDOWS.....	50
CAR CONNECTOR.....	10, 47	HITCHING UP.....	9	REFRIGERATOR:		VENTS.....	26
CEILING FANS.....	26	HITCH INSTALLATION.....	10	DEFROSTING.....	30	WARRANTY.....	3, 4
CEILING VENTS.....	26	HOLDING TANK.....	40	REGISTRATION.....	3	WATER DRAINAGE	
CENTRAL CONTROL PANEL.....	45	HOOK UP.....	16	REGULATOR (LPG).....	28	PROCEDURE.....	20
CHASSIS.....	21	HOME CHECK LIST.....	55	REPAIR CENTERS.....	5	WATER DRAIN VALVES.....	20
CHECK LISTS.....	54	HUMIDITY METER.....	46	REMOVING MOISTURE.....	36	WATER HEATER.....	36
CIRCUIT BREAKERS.....	46	INTERIOR CHECK LIST.....	54	RUNNING GEAR.....	21	WATER INLET.....	38
CITY POWER.....	43	INTERIOR		SCREEN (WATER).....	39	WATER LEVEL INDICATOR.....	45
CLOCK.....	45	MAINTENANCE.....	53	SELF-CONTAINED		WATER PUMP.....	38
DEFROSTING.....	30	JACKING TRAILER.....	16, 22	(DRAINAGE).....	40	WATER PUMP SWITCH.....	38
DRAINAGE SYSTEM.....	40	LUBRICATION CHART.....	53	SELF-CONTAINED		WATER PURIFIER (FILTER).....	39
DUMP VALVE.....	40	LAWS.....	17, 18	(ELECTRICAL).....	44	WATER PRESSURE	
ELECTRICAL		LEVELING.....	15, 16	SERVICE CENTERS.....	5	REGULATOR.....	39
COMPONENTS.....	43	LEVELING BARS.....	9, 10	SEWER CONNECTION.....	40	WATER SCREEN.....	39
ELECTRICAL		LIGHT BULB		SHOWER HEAD.....	39	WATER SYSTEM.....	38
CONNECTOR.....	10	REPLACEMENT.....	24, 26, 51	SINK MAINTENANCE.....	27	WEATHER CHART.....	53
ELECTRICAL INLET.....	43	LIGHTS.....	26	SPECIFICATIONS.....	51-56	WEIGHT: HP RATIO.....	13
ELECTRICAL PANELS.....	46, 48	L.P.G. SYSTEM.....	28	STABILIZING JACK		WINDOWS.....	24
ELECTRICAL SYSTEM.....	43	LOADING.....	10	POSITIONS.....	16	WINTERIZING.....	19

Note: If and when new materials and production techniques are developed which can improve the quality of its product, Airstream, reserves the right to make such changes.



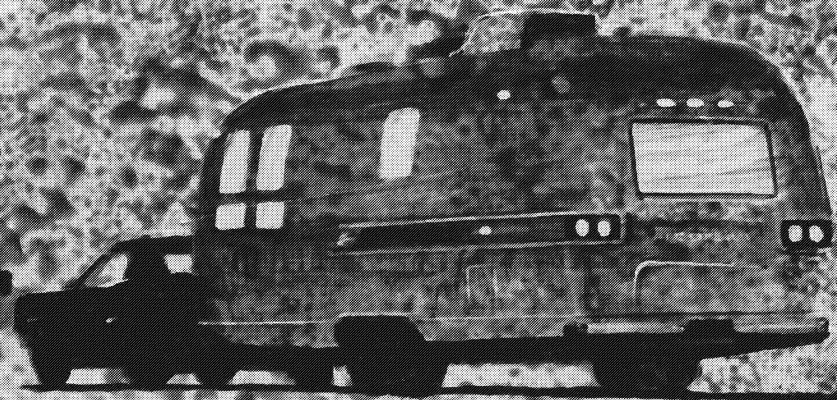

LITHO U.S.A. 1970